

Sirius three WH boiler cascade frame kits

Technical information and installation
instructions covering multiple boiler options for:
50, 60 & 70 kW (100kW - 280kW cascade)
90 & 110 kW (180kW - 660kW cascade)
130 & 150 kW (260kW - 750kW cascade)

**Please refer to the separate
boiler installation instructions
for Sirius three WH.**

Totally dependable.

POTTERTON
COMMERCIAL

Contents

PAGE	TITLE
Page 3	Sirius three WH Introduction to cascade frames
Page 4	Installation
Page 5-13	Schematics
Page 5	2 boiler in-line cascade for 50, 60 & 70 KW boilers – up to 140 KW
Page 5	2 boiler in-line cascade for 90, 110, 130 & 150 KW boilers – up to 300 KW
Page 6	3 boiler in-line cascade for 50, 60 & 70 KW boilers – up to 210 KW
Page 6	3 boiler in-line cascade for 90, 110, 130 & 150 KW boilers – up to 450 KW
Page 7	4 boiler in-line cascade for 50, 60 & 70 KW boilers – up to 280 KW
Page 7	4 boiler in-line cascade for 90, 110, 130 & 150 KW boilers – up to 600 KW
Page 8	5 boiler in-line cascade for 90, 110, 130 & 150 KW boilers – up to 750 KW
Page 9	6 boiler in-line cascade for 90 & 110 KW boilers – up to 660 KW
Page 10	Connection kit – DN65 to DN80 for 50, 60 & 70 KW boilers
Page 10	Connection kit – DN100 for 90, 110, 130 & 150 KW boilers
Page 11	Low Loss Header - DN80 for 50, 60 & 70 KW boilers
Page 11	Low Loss Header - DN100 for 90, 110, 130 & 150 KW boilers
Page 12	Flange fittings – DN65, DN80
Page 13	Flange fittings – DN100
Page 14-20	Accessories
Page 14	Corner group cascade for 50, 60 & 70 KW boilers – up to 280 KW
Page 15	Corner group cascade for 90 & 110 KW boilers – up to 440 KW
Page 16	Alternative cascade connection options for 90 & 110 KW boilers Inc. corner manifold– up to 660 KW
Page 17	Cascade connection accessories – Low Loss Headers
Page 18	Cascade connection accessories - for 50, 60 & 70 KW boilers
Page 19	Cascade connection accessories - for 90 & 110 KW boilers
Page 20	Cascade connection accessories – for 130 & 150 KW Boilers
Page 21-31	Assembly
Page 32	Fitting the Insulation
Page 33-34	Options
Page 35	Service & Maintenance

Sirius three

Wall Hung Condensing Boilers

50 to 150 KW boiler range (or 100 to 750 KW cascade options)

The Sirius three WH boiler range is perfectly suited to single boiler installations and modular boiler cascades, due to its very flexible modulation capability and ability to meet varying heat requirements; therefore greatly improving boiler efficiencies.

It is an extremely light-weight and dimensionally compact appliance with an industry leading range of modulation up to 9:1 for a single unit, (all models within the range).

This modulation range can be enhanced with cascade frame installations. For every additional boiler added to a system, the modulation range improves by a multiple of up to 9, so three boilers can attain a modulation range of up to 27:1.

The size, weight and performance benefits, alongside other key points such as stainless steel heat exchangers and flexible boiler control options, firmly position the Sirius boiler range as the boiler range of choice for cascade systems.

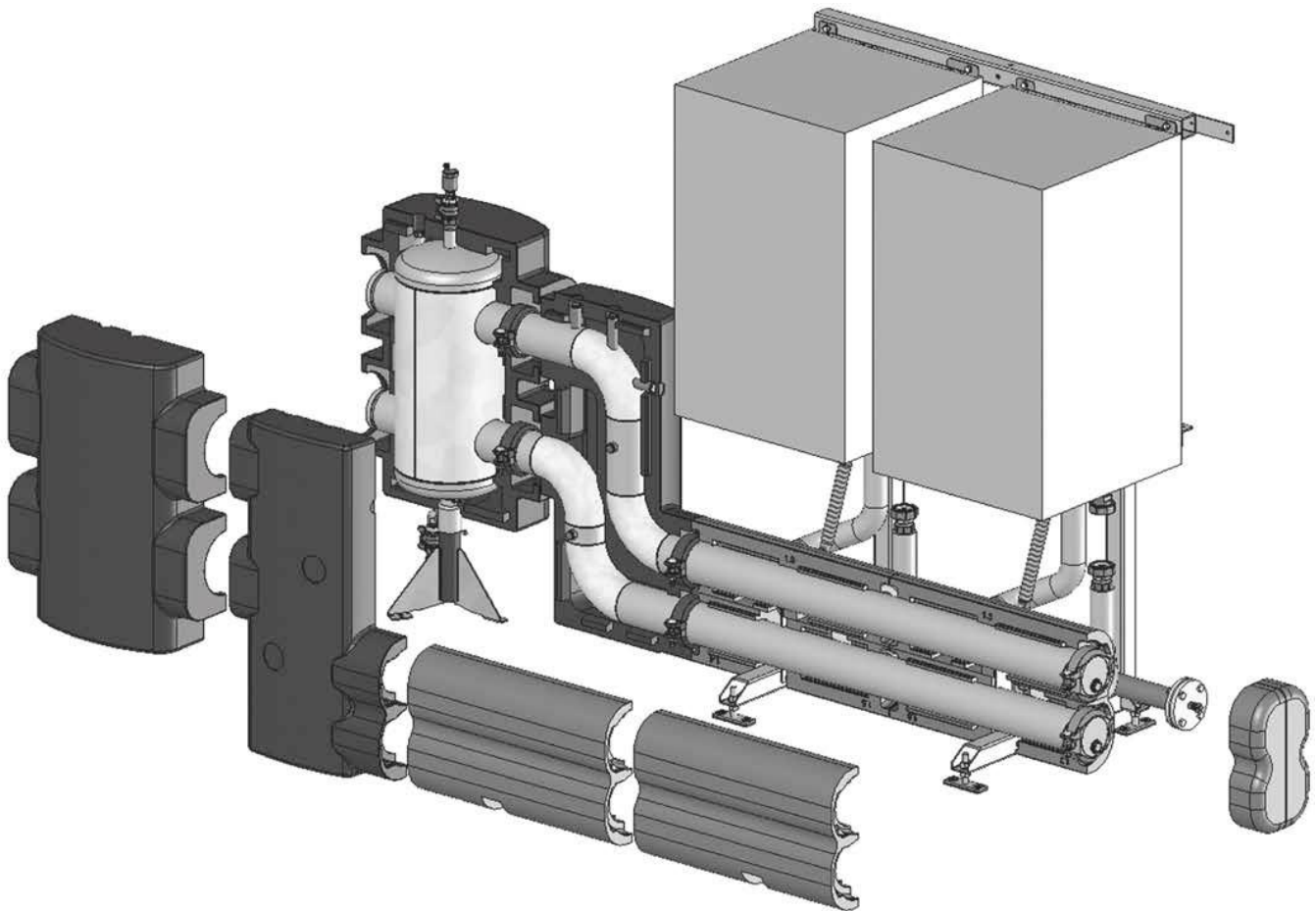

Installation

Required tools.



1 socket set



1 electric drill



1 Stilson



1 Adjustable wrench

Safety.



- Read the installation instructions before use



- Risk of cuts



- Risk of being crushed



- Risk of increased temperature



- Risk of items falling during installation



- Please ensure you pressure test the gas and heat pipe system to ensure there is no leakage



Manual Handling

GENERAL

The following advice should be adhered to, from when first handling these products to the final stages of installation, and also during maintenance.

Most injuries as a result of inappropriate handling and lifting are to the back, but all other parts of the body are vulnerable, particularly shoulders, arms and hands.

Health & Safety is the responsibility of EVERYONE.

There is no 'safe' lifting limit for one man - each person has different capabilities. The products should be handled and lifted by THREE PEOPLE.

Do not handle or lift unless you feel physically able.

Wear appropriate Personal Protection Equipment e.g. protective gloves, safety footwear etc.

PREPARATION

Co-ordinate movements - know where, and when, you are all going.

Minimise the number of times needed to move heavier components - plan ahead.

Always ensure when handling or lifting the route is clear and unobstructed. If possible avoid steps, wet or slippery surfaces, unlit areas etc. always take special care.

TECHNIQUE

When handling or lifting always use safe techniques - keep your back straight, bend your knees.

Don't twist - move your feet, avoid bending forwards and sideways and keep the load as close to your body as possible.

Where possible transport the boiler using a sack truck or other suitable trolley.

Always apply a firm grip and before lifting feel where the weight is concentrated to establish the centre of gravity, repositioning yourself as necessary.

The circumstances of each installation are different. Always assess the risks associated with handling and lifting according to the individual conditions.

If at any time when installing these products you feel that you may have injured yourself, STOP !!

DO NOT 'work through' the pain - you may cause further injury.

IF IN ANY DOUBT DO NOT HANDLE OR LIFT THE EQUIPMENT - OBTAIN ADVICE OR ASSISTANCE BEFORE PROCEEDING!!

Schematics

Wall Hung Condensing Boilers

The 2 boiler in-line cascade frames for Sirius three WH 50, 60 & 70 kW outputs have a manifold pipework size of DN65, increasing to DN80 via S connection set from the Low Loss Header. The connection to the system is a DN80 PN6 flange.

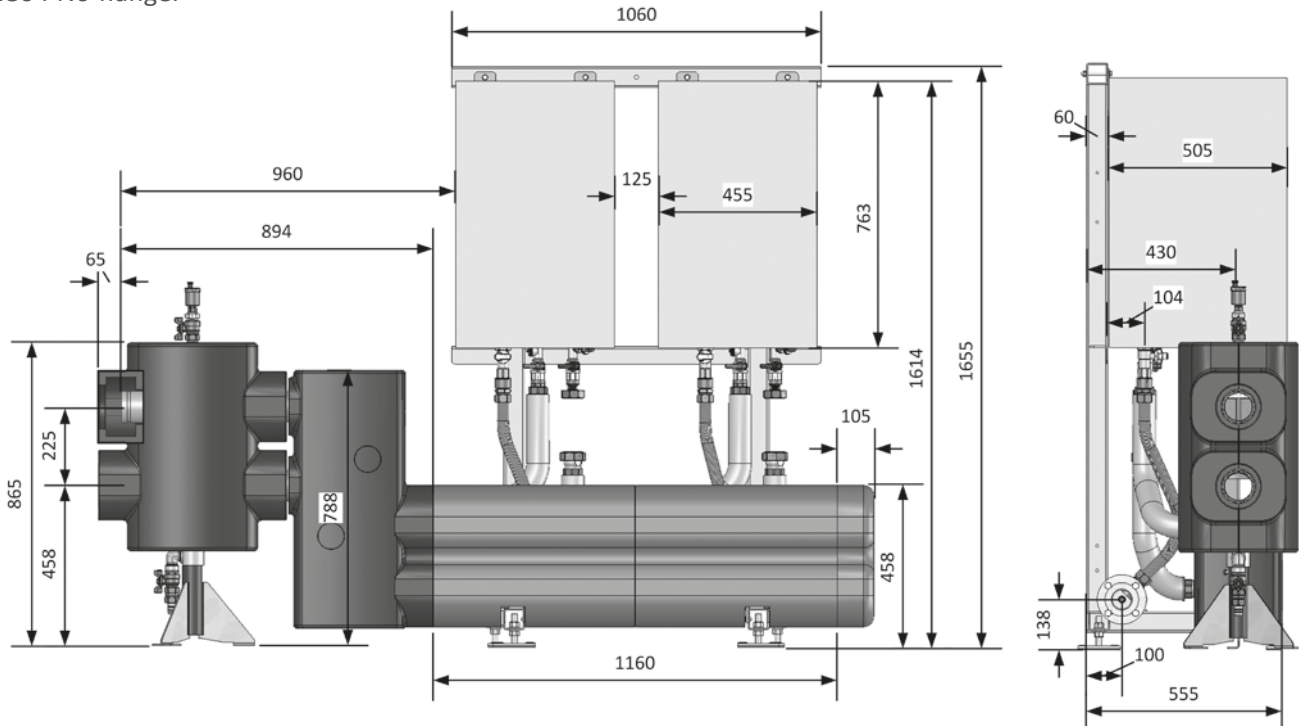

The 2 boiler in-line cascade frame for Sirius three WH 90 to 150 kW outputs have a Manifold pipework size of DN100 and the frame sizes differ from the above due to the boiler size being larger. DN100 flanged faced connections are supplied for system connection.

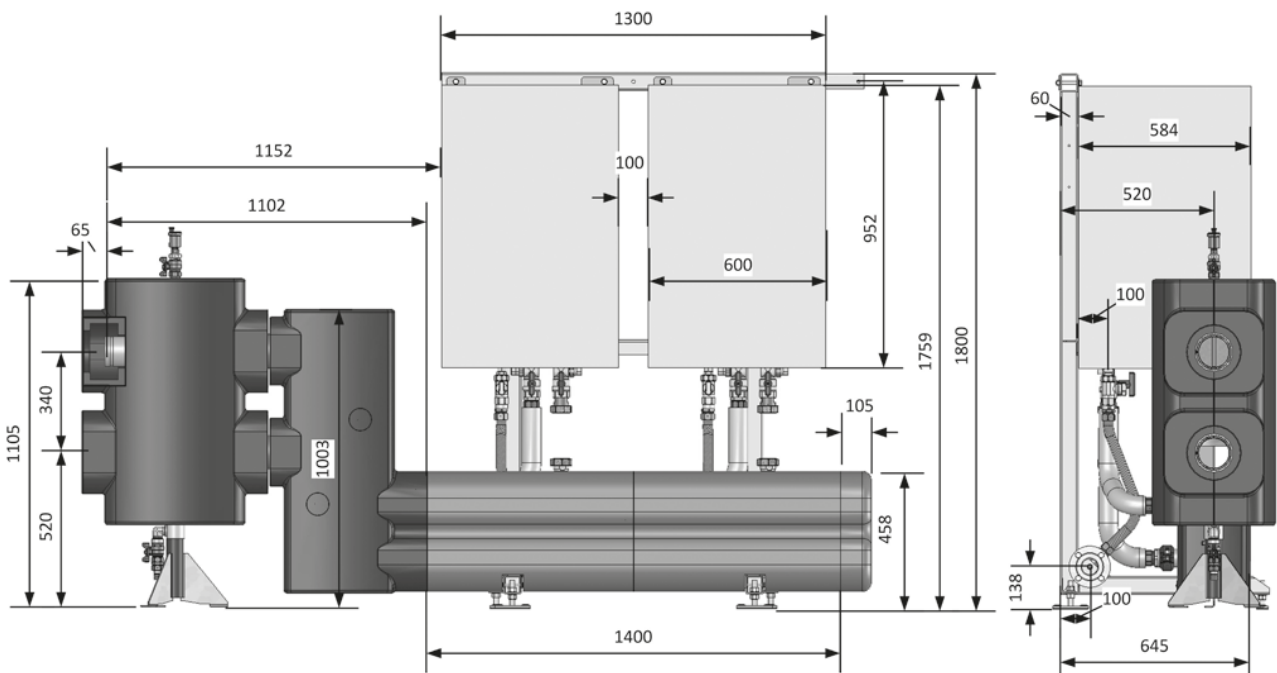

Schematics

Wall Hung Condensing Boilers

DN65 3 boiler in-line cascade frames for Sirius three WH 50,60 &70 KW outputs

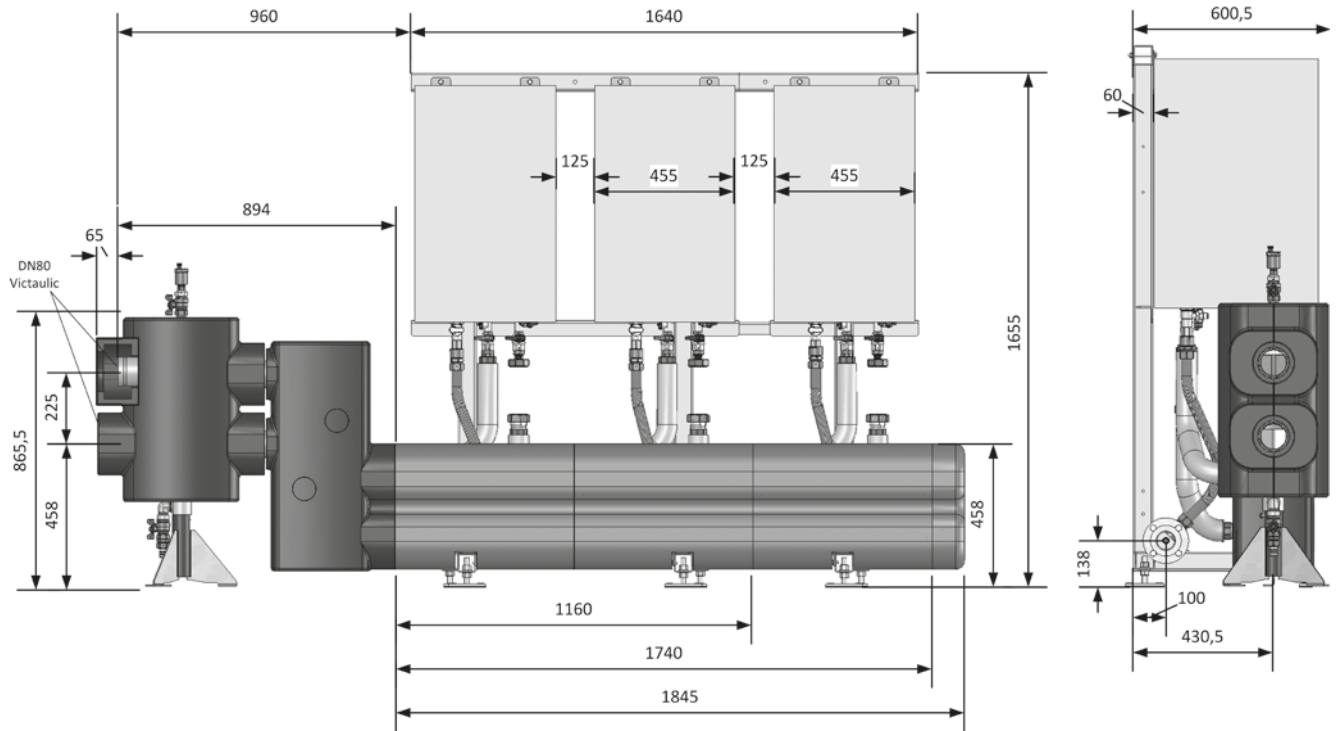

DN100 3 boiler in-line cascade frame for Sirius three WH 90 to 150kW outputs

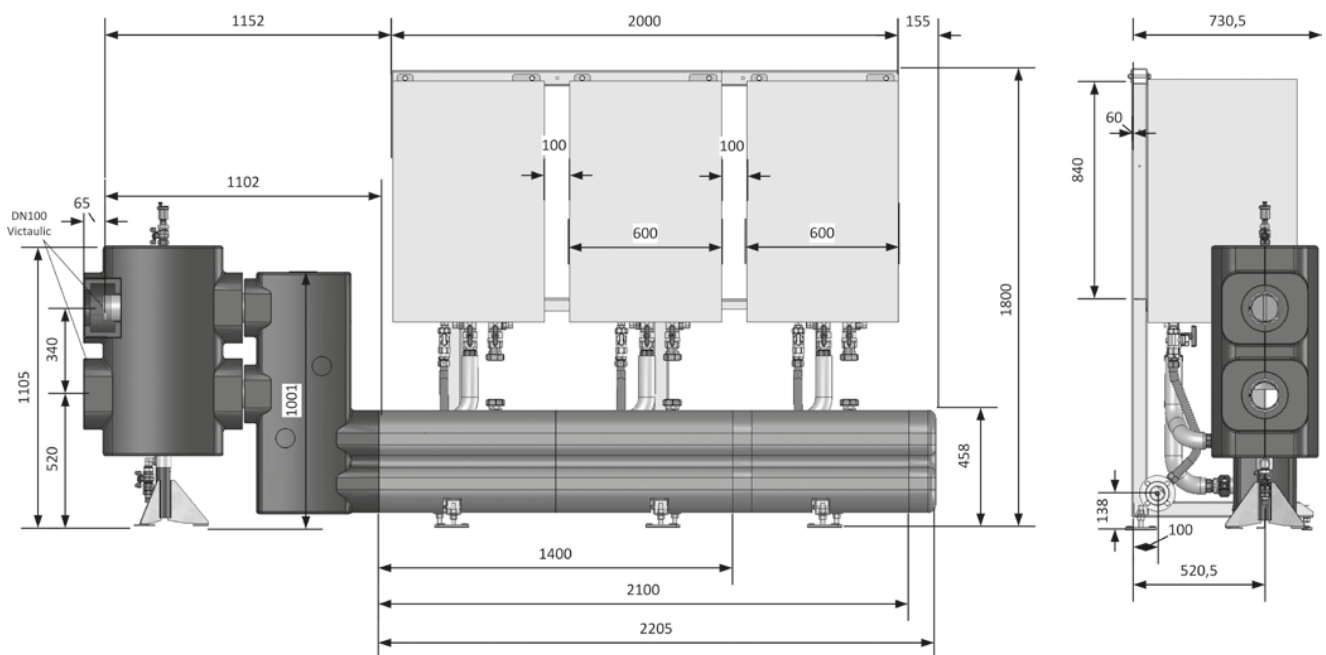

Schematics

Wall Hung Condensing Boilers

DN65 4 boiler in-line cascade frames for Sirius three WH 50, 60 & 70 kW outputs.

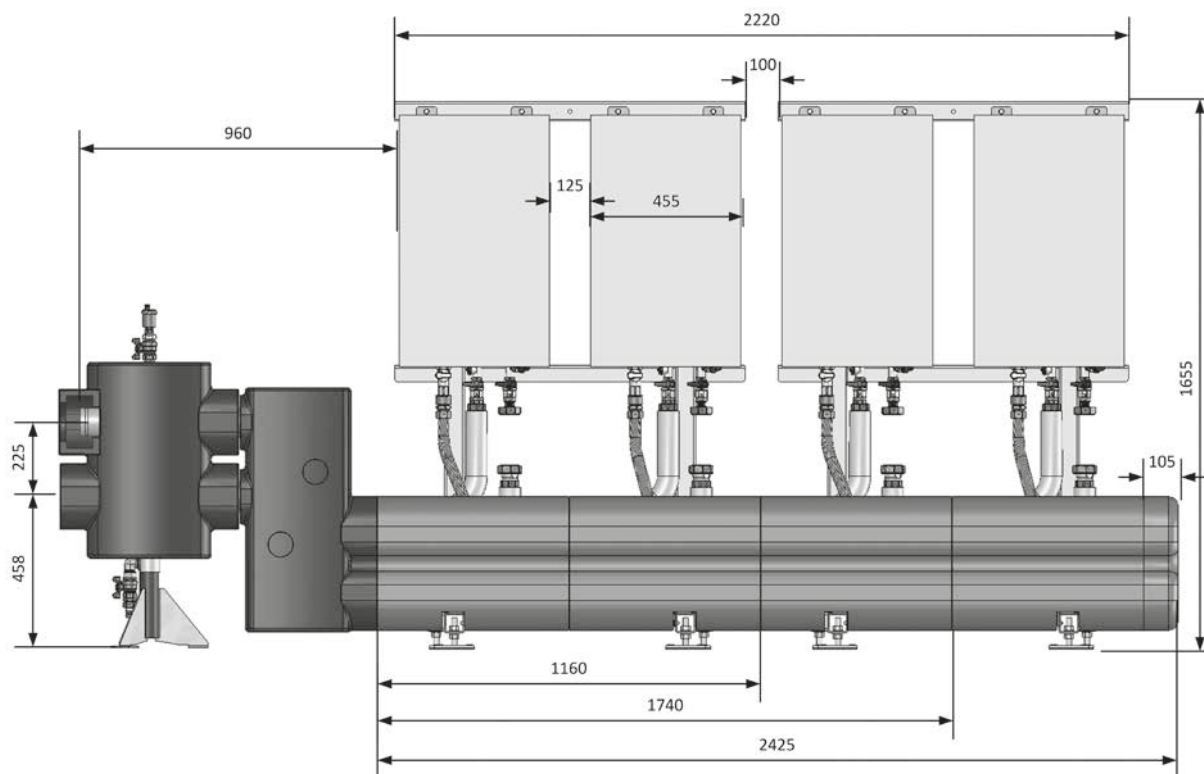

DN100 4 boiler in-line cascade frame for Sirius three WH 90 to 150 kW outputs

Frame sizes differ from the below due to large boiler dimensions.

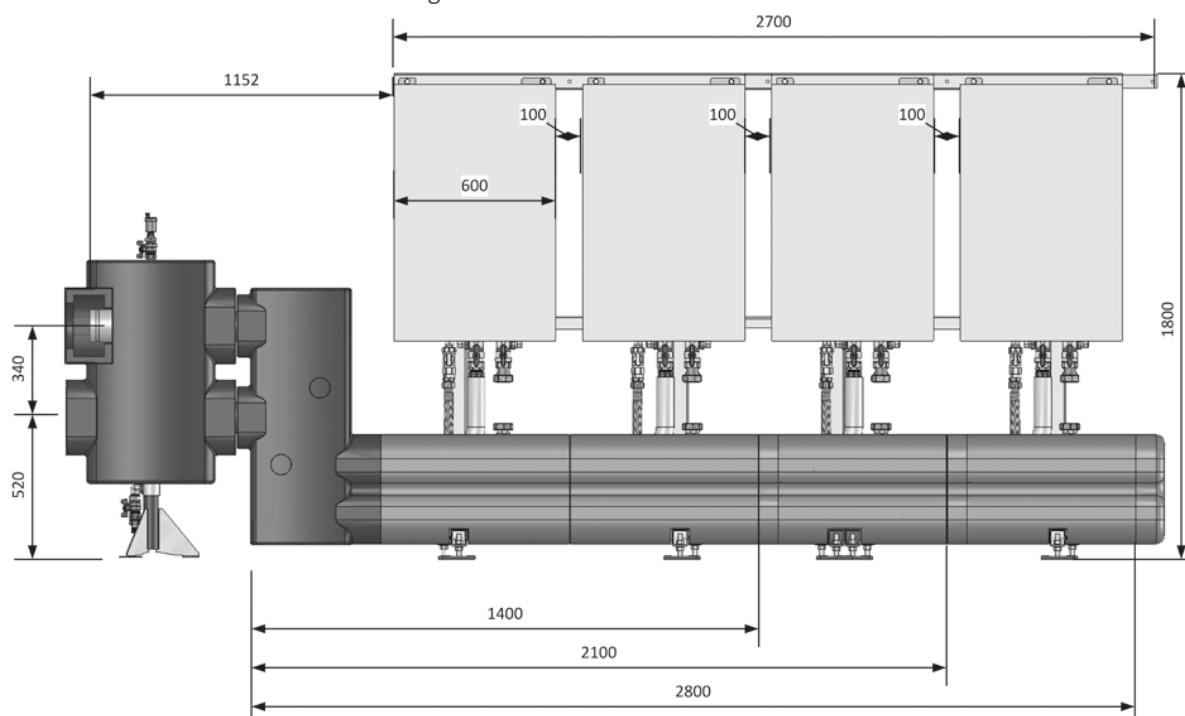

Schematics

Wall Hung Condensing Boilers

DN100 5 boiler in-line cascade frame for Sirius three WH 90 to 150kW outputs

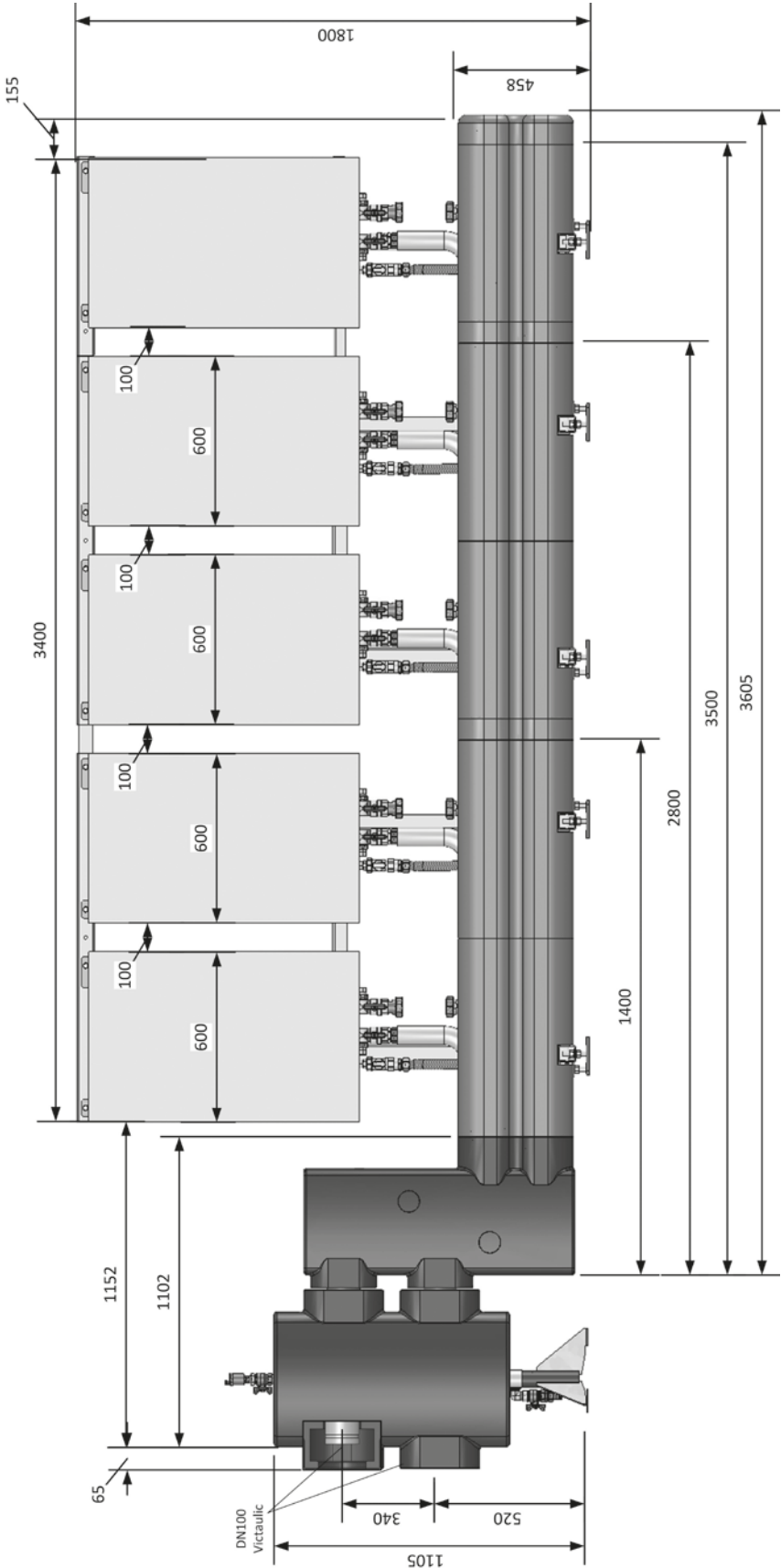

Schematics

Wall Hung Condensing Boilers

DN100 6 boiler
in-line cascade
frame for Sirius
three WH 90
& 110kW outputs
(Excludes 130 &
150kW boilers)

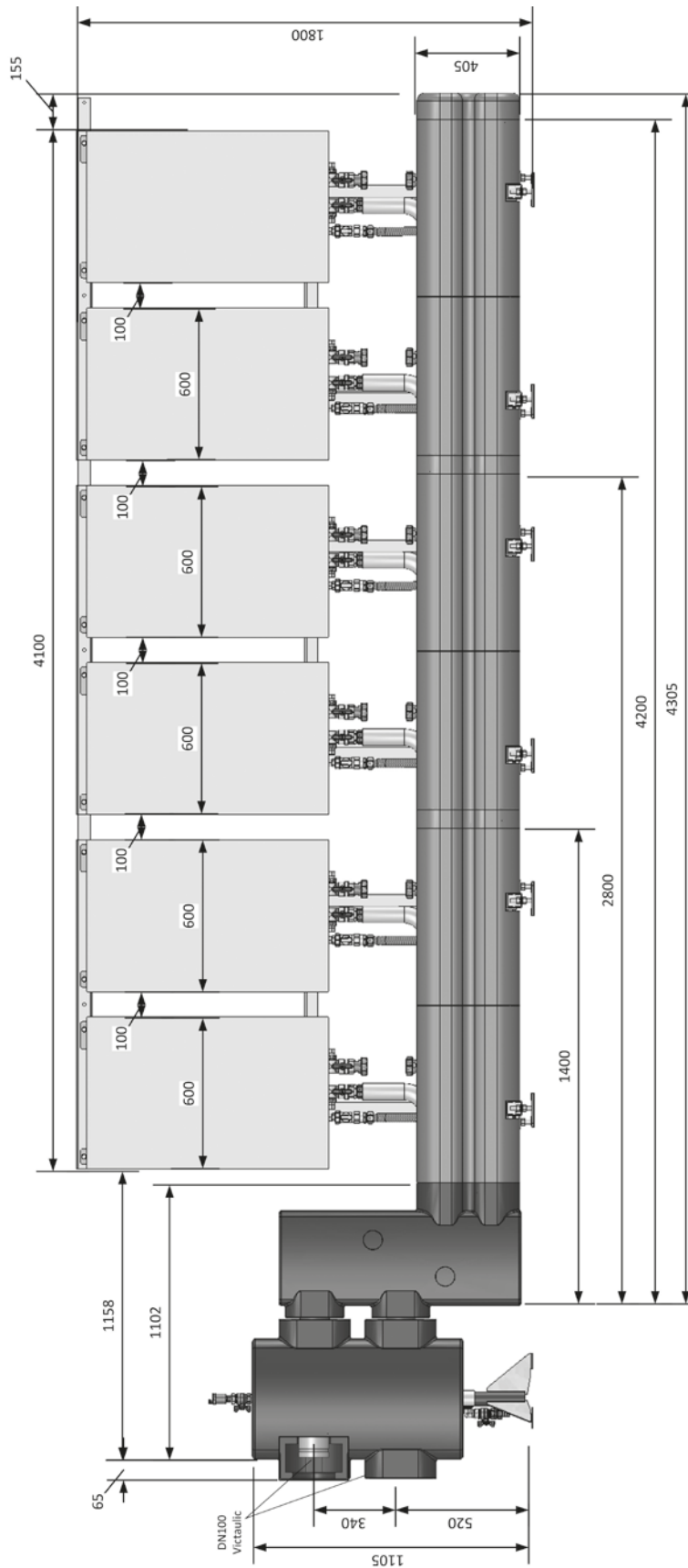

Schematics

Wall Hung Condensing Boilers

DN65 to DN80 "S" connection set

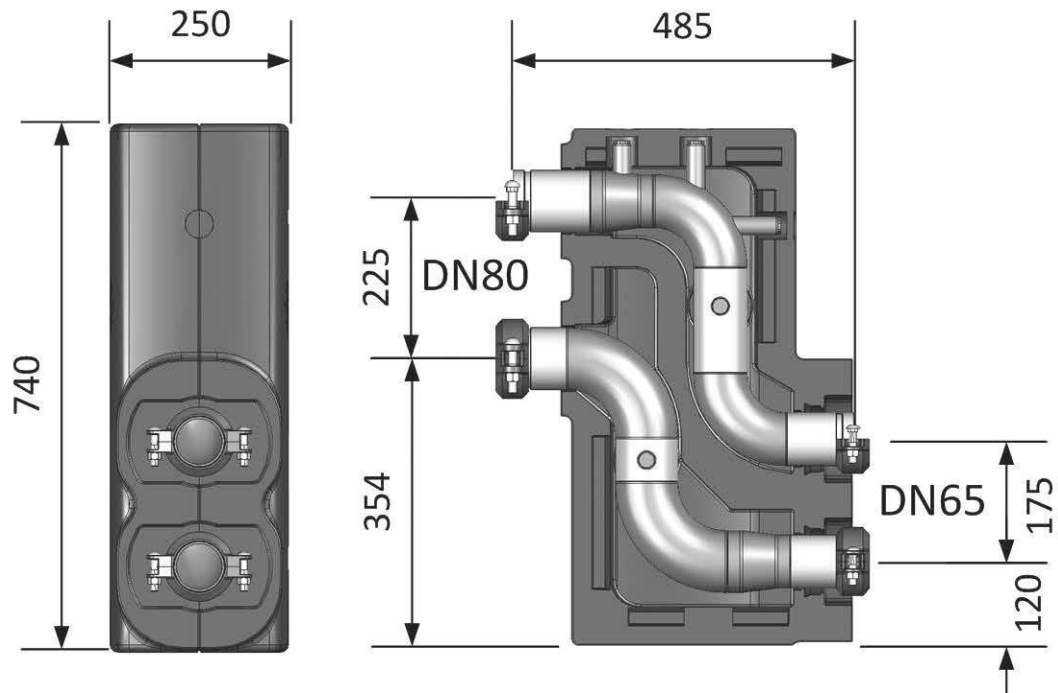

DN100 "S" connection set

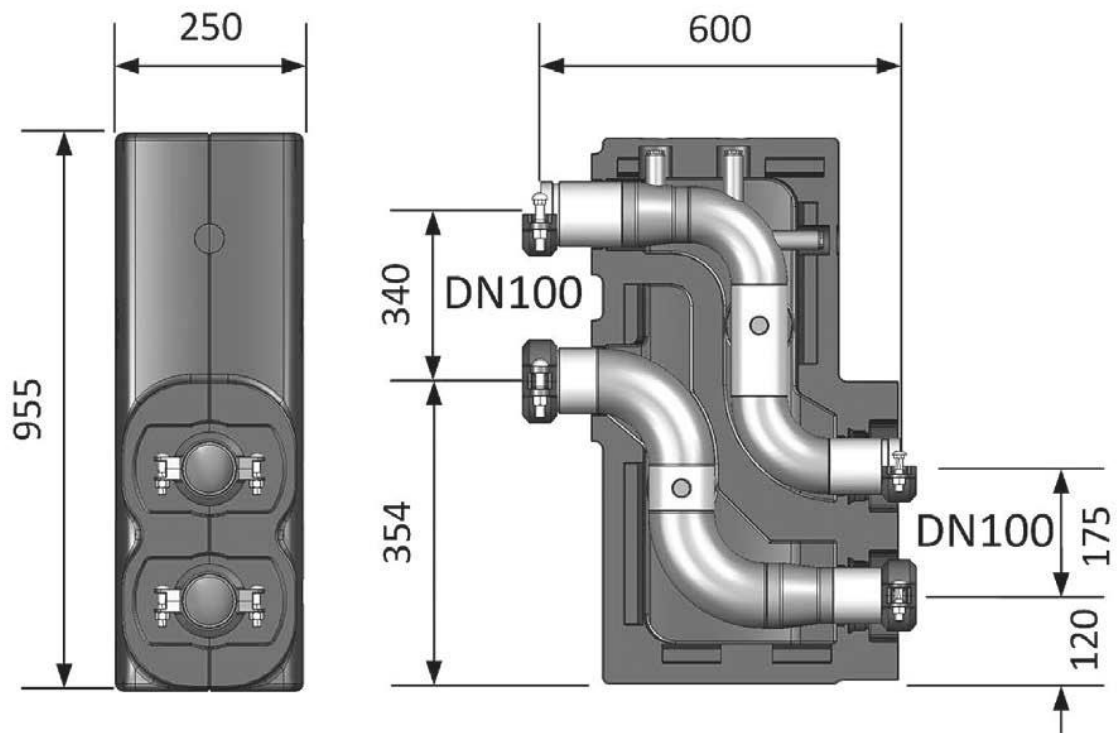

Schematics

Wall Hung Condensing Boilers

DN80 Low Loss Header

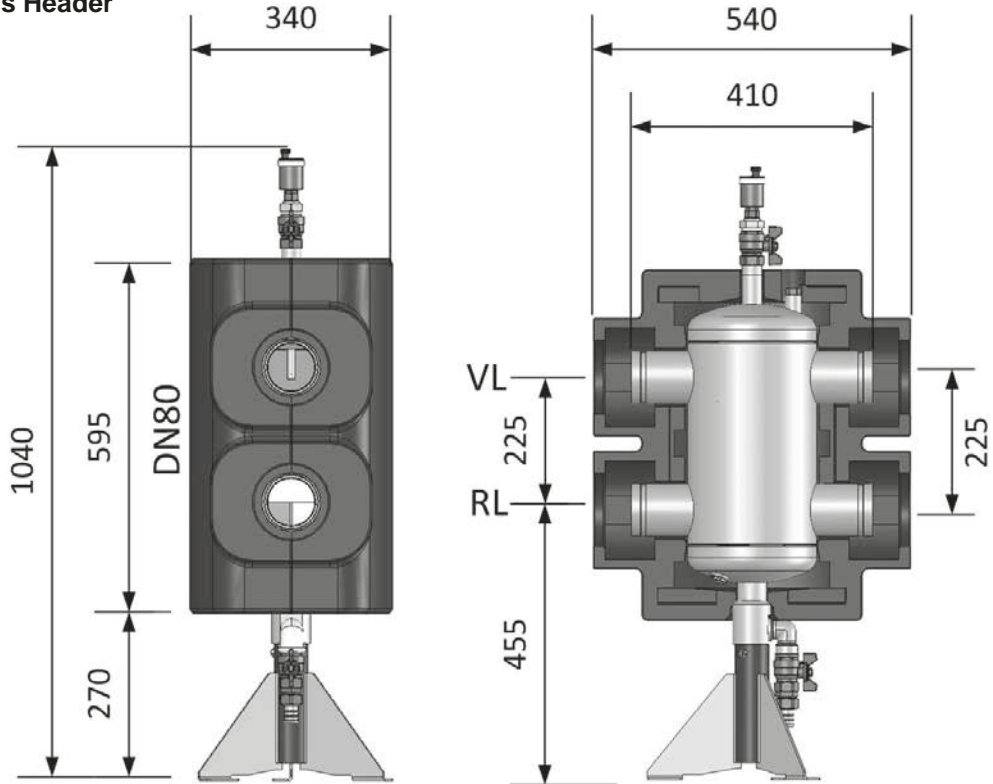

DN100 Low Loss Header

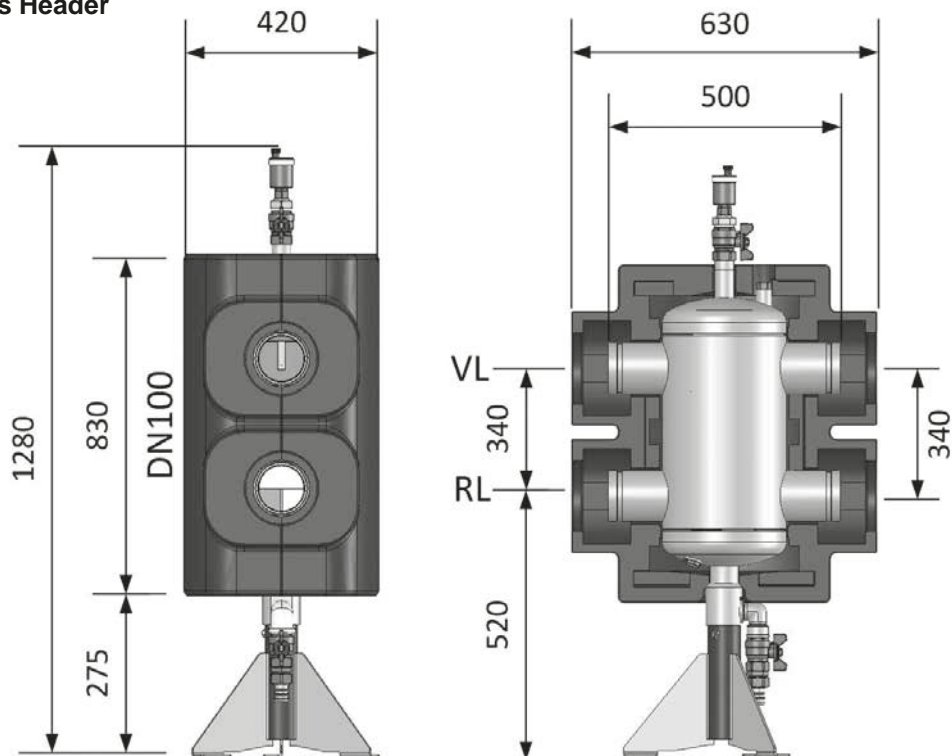

Schematics

Wall Hung Condensing Boilers

DN65 PN6 flange faced system connections

The below pair of flanged faced connections are supplied with all DN65 cascade frame options, along with the Victaulic clamp fittings for connection either directly on to the cascade frame manifolds, or if selected, the low loss header side ports. All supplied flanged faced fittings are PN6.

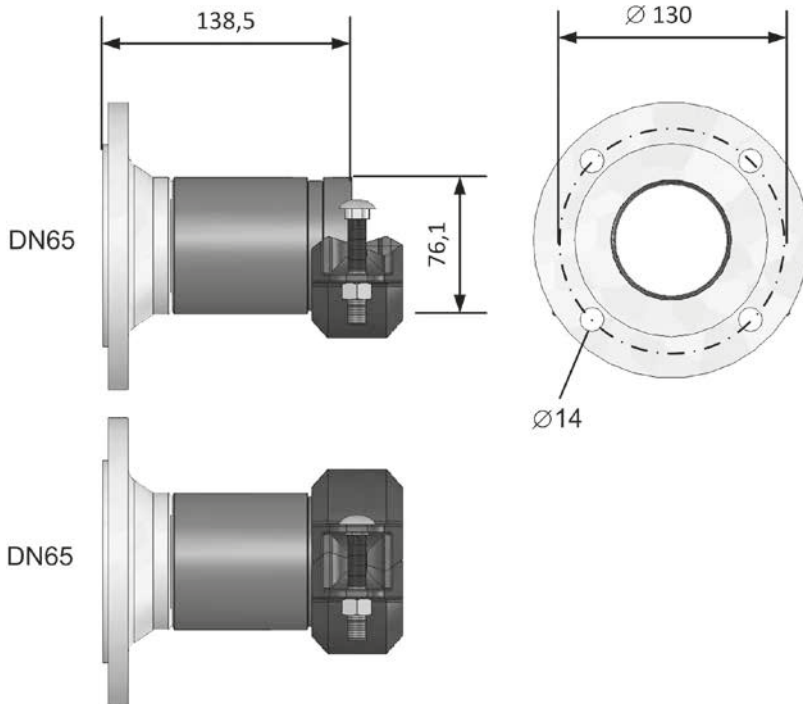

DN100 PN6 flange faced system connections

The below pair of flanged faced connections are included with all DN100 cascade frame options when supplied without our Low Loss Header, along with The Victaulic clamp fittings. All supplied flanged faced fittings are PN6.

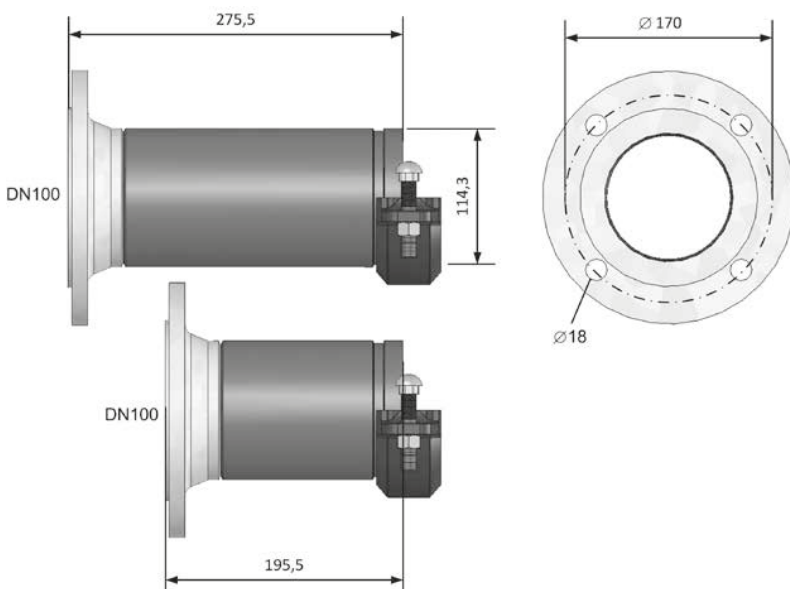

Schematics

Wall Hung Condensing Boilers

DN100 PN6 flange faced system connections

The below pair of flanged faced connections are included with all DN100 cascade frame options supplied with the Low Loss Header, along with The Victaulic clamp fittings. All supplied flanged faced fittings are PN6.

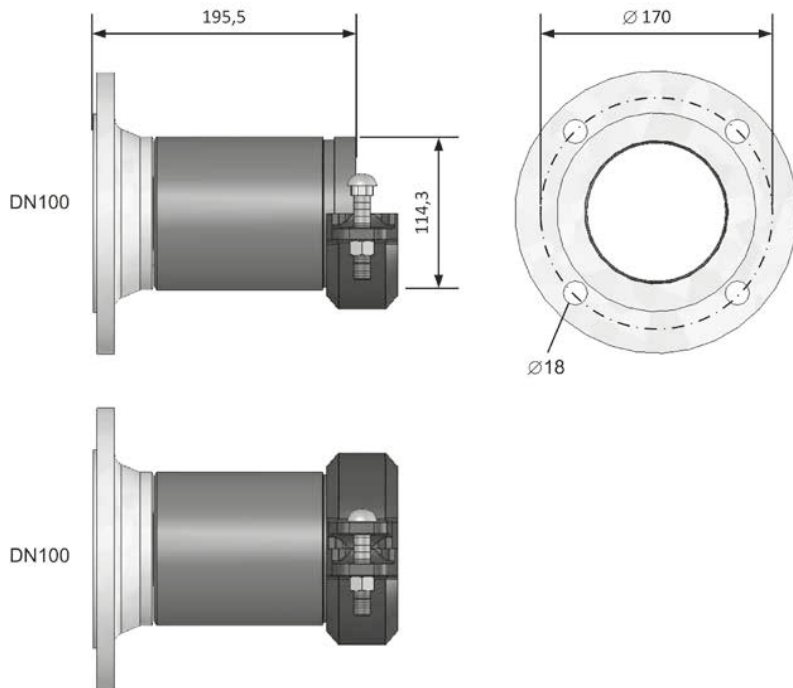

Schematics

Wall Hung Condensing Boilers

DN65 4 boiler corner group cascade frame for Sirius three WH 50,60 &70 KW output

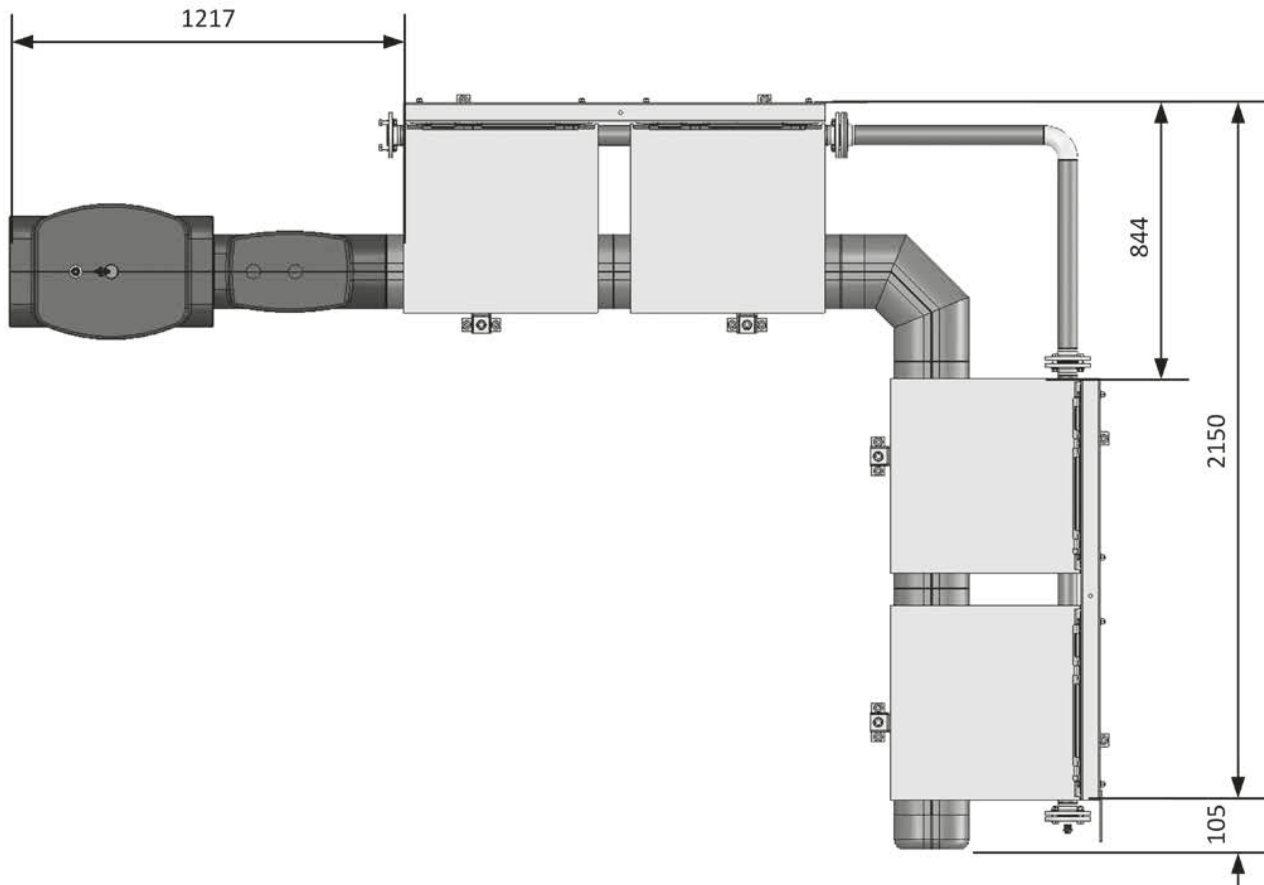
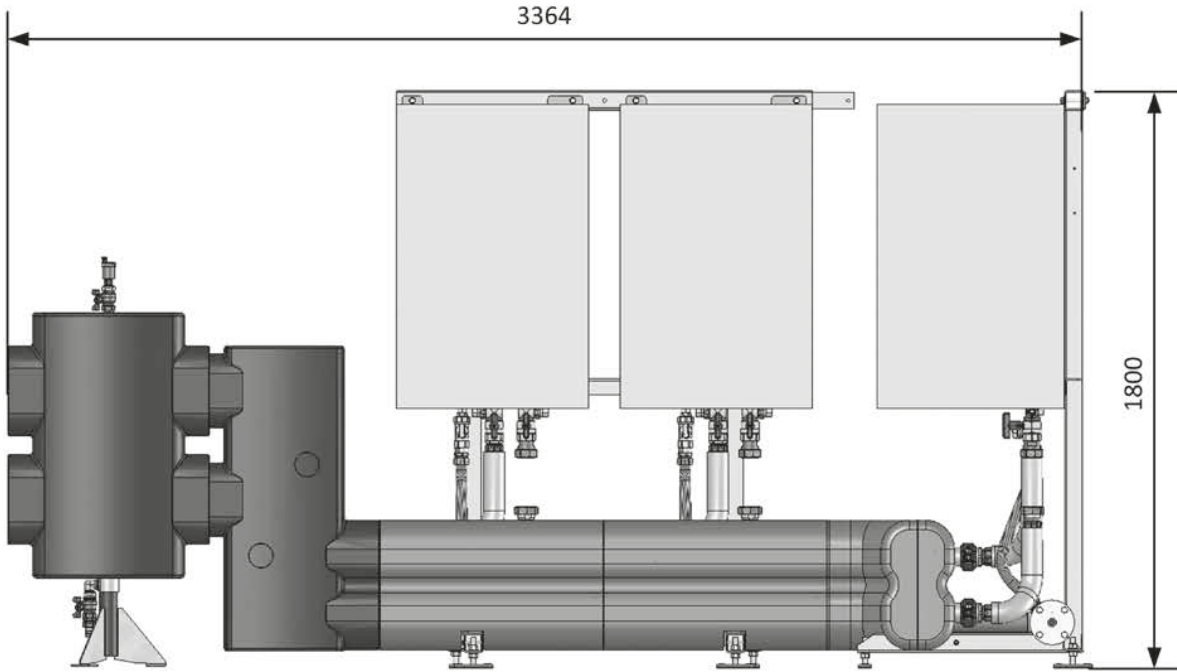

Accessories

Wall Hung Condensing Boilers

DN100 4 boiler corner group cascade frame for Sirius three WH 90 & 110kW outputs (excludes 130 & 150kW boilers)

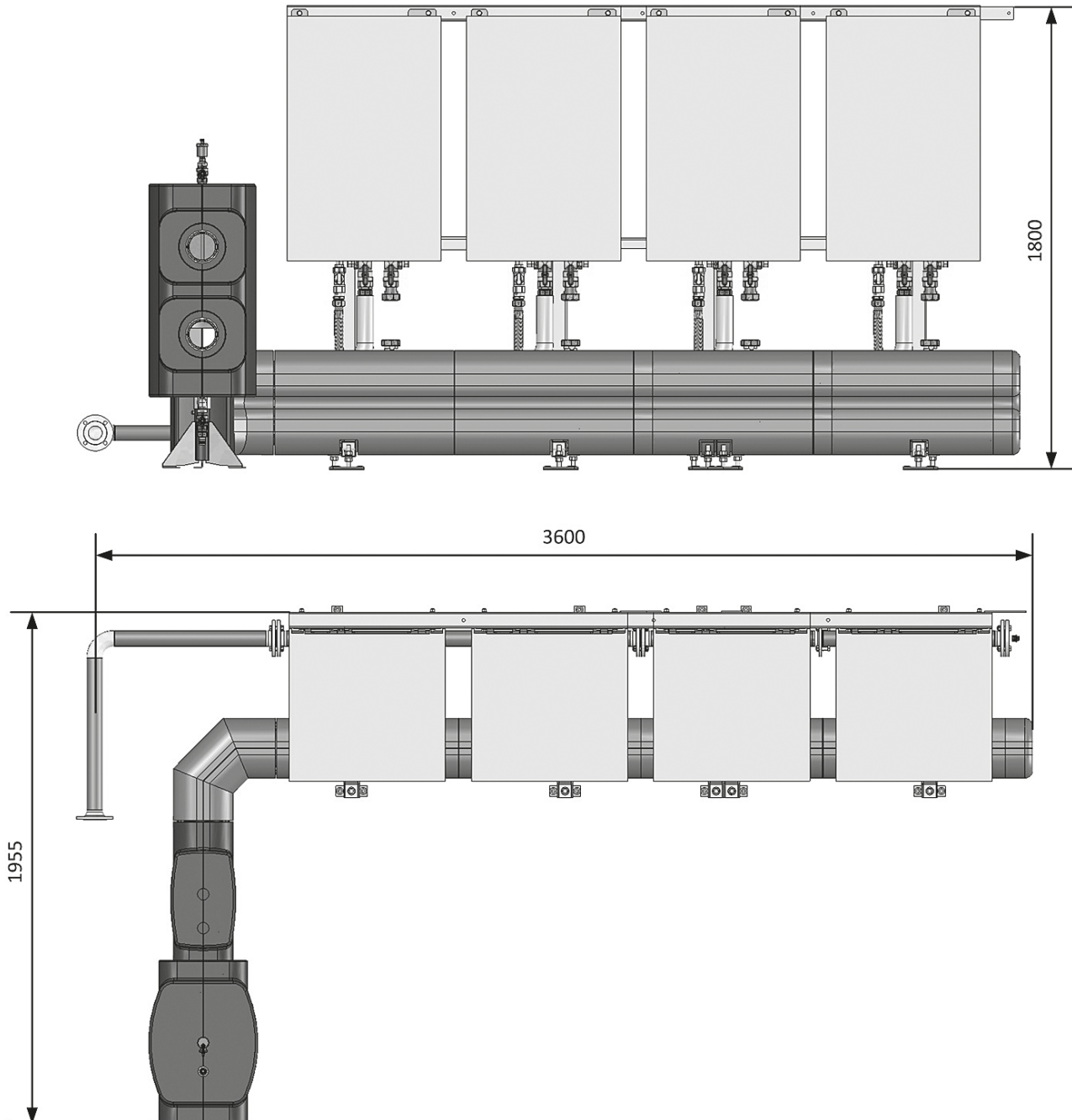

Accessories

Wall Hung Condensing Boilers

DN65 & DN100 corner extension

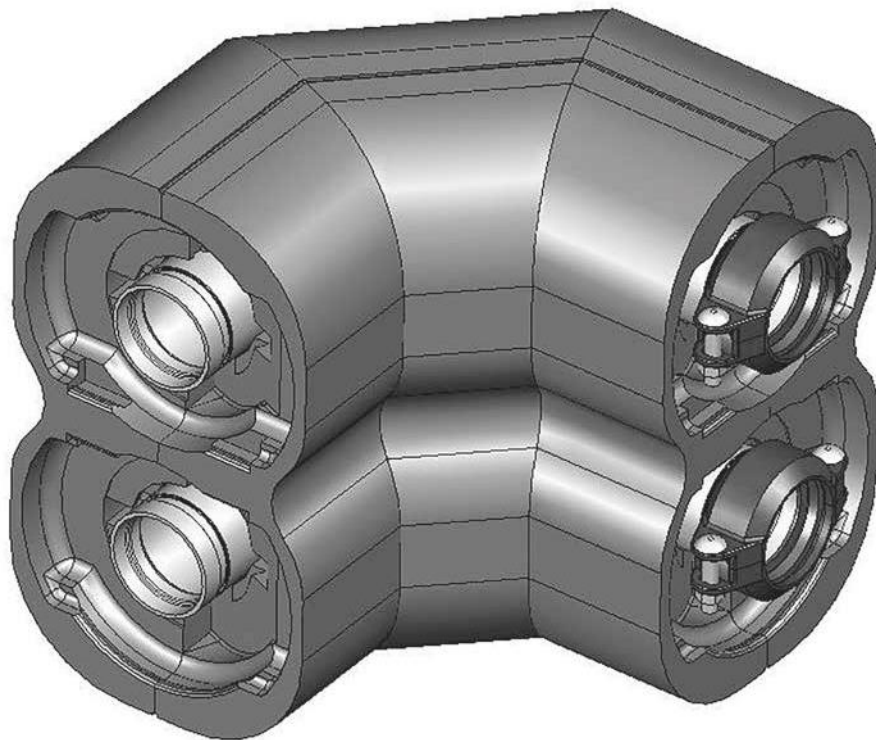

90° corner extension piece (accessory)

This item is supplied in 2 sizes; DN65 for smaller boiler systems and DN100 for larger cascades.

This accessory item allows for alternative configurations to in-line cascades. A very useful feature for smaller or busy plant rooms where space is a premium.

It allows for the boiler cascade to be configured in corner groups, in “U” shapes or simply to angle the Low Loss Header into a tight corner. Please see pages 14 to 15 for some examples of possible configurations.

It is supplied with matching insulation and correctly sized Victaulic clamps for easy inclusion into the main kit.

Accessories

Wall Hung Condensing Boilers

Potterton Commercial offer a range of optional ancillary equipment that can further improve the quality and reliability of a cascade frame kit installation. This range of accessories includes;

- Common flue headers and kits
- Low Loss Header
- Flanged fittings
- Magnetic separator

Low Loss Header:

This device is a multi-purpose optional extra which encourages air separation, provides dirt separation, magnetic filtration and system flow & return water diversion within one solution.

2 sizes of Low Loss Header are offered and these supplement the kit options for larger and smaller boilers; a DN80 for smaller cascades and a DN100 for larger system requirements.

The system side connections of the Low Loss Header are supplied with a sized pair of flange faced connections that are DN80 or DN100 PN6, with a pair of Victaulic clamps to connect them to the outlet ports of the Low Loss Header.

The product also requires a pair of "S" transition bends, (as featured on page 10 of this document), in order to complete the full kit. All pipe work is connected using the Victaulic clamp system.

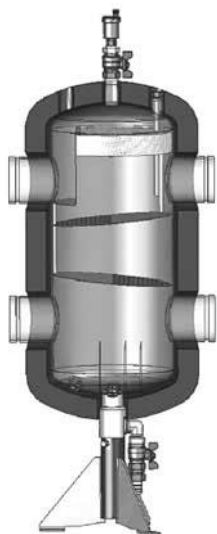

Type	Flow rate m ³ /hr	Max. KW load	Connection size	Potterton Commercial Part Number
DN80	12 m ³ /hr	280KW	ØDN80	5140434
DN100	32 m ³ /hr	750KW	ØDN100	5140435

Calculated @ ΔT = 20K

Magnets:

An optional set of 2 magnets are available for insertion into the Low Loss Header for magnetic filtration. 2 ports are available at the base of the Low Loss Header where the magnets can be inserted.

(Part No 5141046 for DN80 low loss header)

(Part No 5141047 for DN100 low loss header)

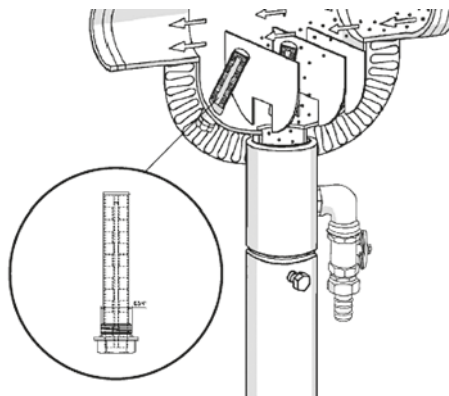

Accessories

Wall Hung Condensing Boilers

DN65 Boiler
to manifold
Flow & Return
connection sets
(50, 60 & 70kW)

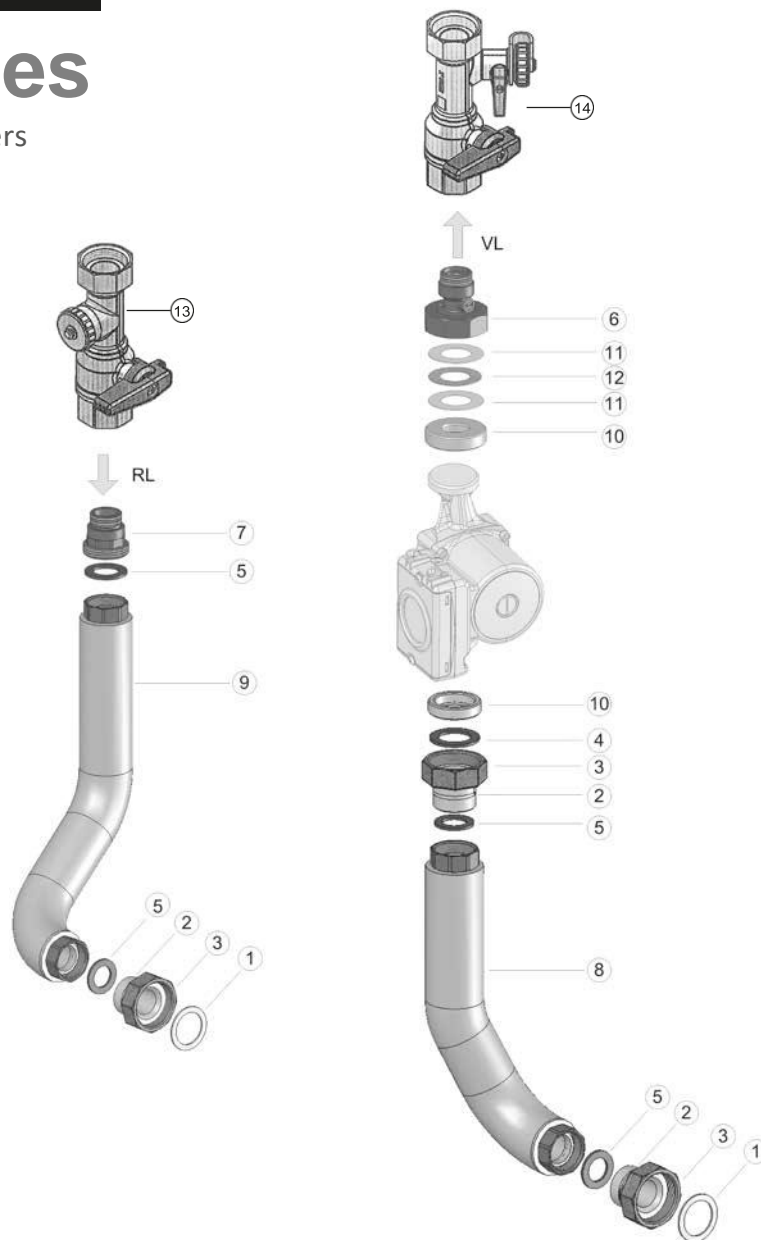

Number	Description	Quantity
1	Gasket 2"	2
2	Connection piece 2" flange x 1 1/2" male thread	2
3	Cap nut 2"	3
4	Gasket EPDM 2"	1
5	Gasket EPDM 1 1/2"	4
6	Non return valve 2" female x 1" male thread	1
7	Reduction piece 1 1/2" male x 1" male	1
8	Connection pipe boiler return	1
9	Connection pipe boiler flow	1
10	Reduction piece 2" male x 1 1/2" female (flat-	2
11	Gasket EPDM 2"	2
12	Stainless steel disc 2"	1
13	Flow isolation valve 1"	1
14	Return isolation valve 1"	1

Accessories

Wall Hung Condensing Boilers

DN100 Boiler to manifold
Flow & Return
connection sets
(90 & 110kW)

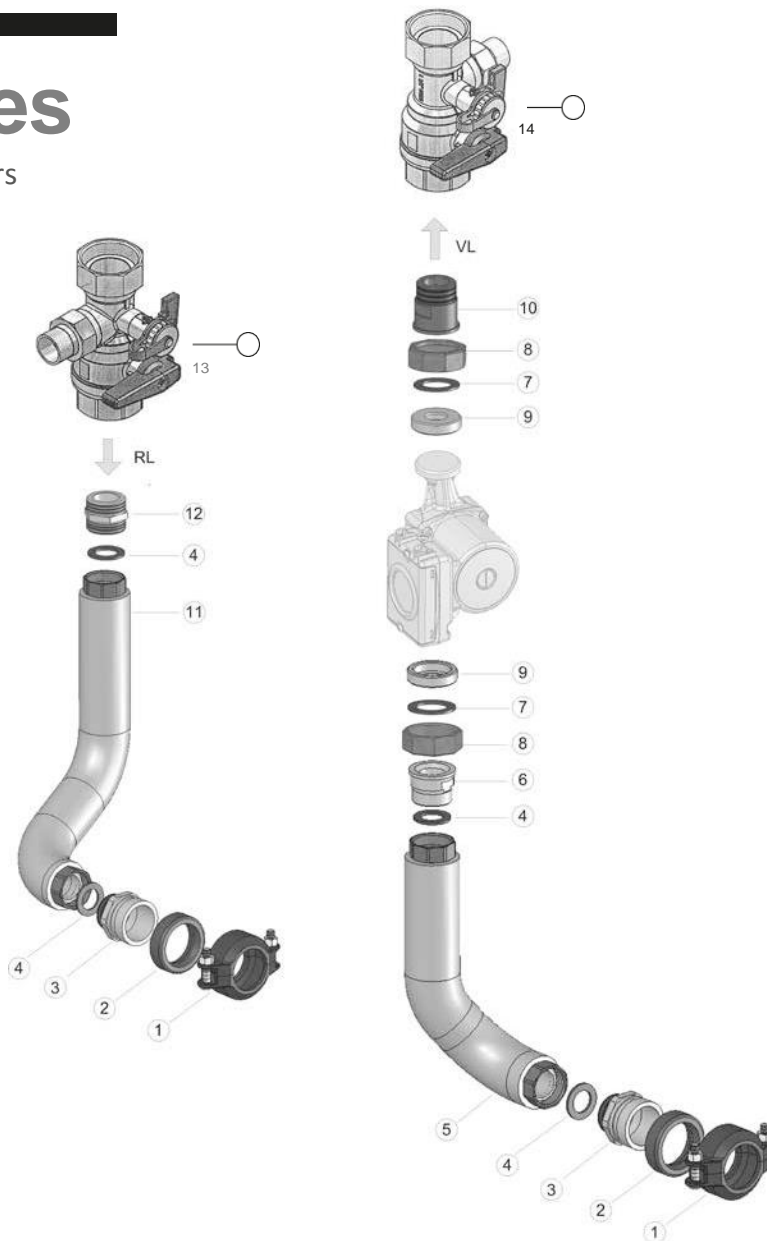

Number	Description	Quantity
1	Victaulic clip DN50	2
2	Victaulic seal DN50	2
3	Reduction pipe Victaulic DN50 x 1 1/2" male thread	3
4	Gasket EPDM 1 1/2"	1
5	Connection pipe boiler return	4
6	Connection piece 2" flange x 1 1/2" male thread	1
7	Gasket EPDM 2"	1
8	Cap nut 2"	1
9	Reduction piece 2" male x 1 1/2" female (flat-	1
10	Non return valve 2" flange x 1 1/2" male thread	2
11	Connection pipe boiler flow	2
12	Double nipple 1 1/2"	2
13	Flow isolation valve 1 1/2"	1
14	Return isolation valve 1 1/2"	1

Accessories

Wall Hung Condensing Boilers

DN100 Boiler
to manifold
Flow & Return
connection sets
(130 & 150kW)

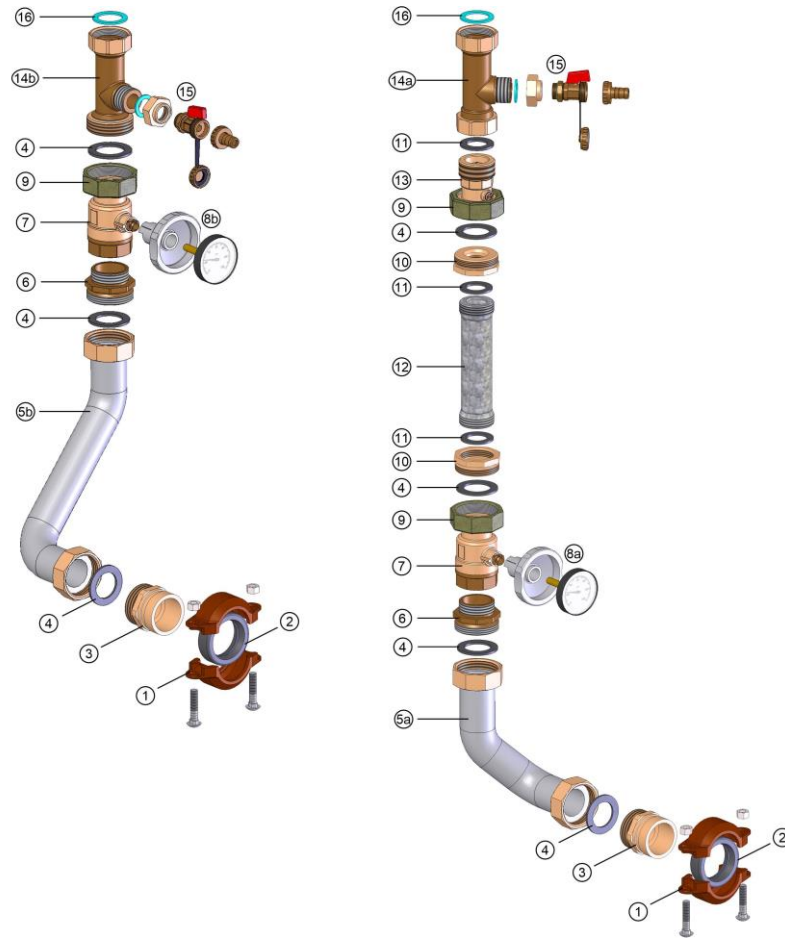

Number	Description	Quantity
1	Victaulic clip DN50	2
2	Victaulic seal DN50	2
3	Reduction pipe Victaulic DN50 x 2" male	2
4	Gasket EPDM 2"	7
5a	Connection pipe boiler flow	1
5b	Connection pipe boiler return	1
6	Reduced double nipple 2" x 1 1/2"	2
7	Ball Valve 1 1/2"	2
8a	Thermometer Red (Flow)	1
8b	Thermometer Blue (Return)	1
9	Cap Nut 2"	3
10	Reducer 2" male x 1 1/2" female (flat sealing)	2
11	EPDM Gasket 1 1/2"	3
12	Connecting Piece (180mm pump option)	1
13	Non return valve 1 1/2" male	1
14a	T - piece flow	1
14b	T - piece return	1
15	Fill and drain valve	2
16	Gasket 1 1/2"	2

Assembly

Page 20

Tracpipe Gas Fitting Pack (50 to 110kW)

A

Number	Description	Quantity
1	Gas isolation valve	1
2	Autoflare DN28 x 1"	2
3	Cap nut DN28	2
4	Split rings	2 Pair
5	Tracpipe DN28	1
6	Hexagon screw M8 x 20mm	2
7	Fix point gas manifold	2
8	Washer 8, 4 x 16 x 1.6mm	2
9	Hexagon nut M8	2
10	Gaspipeline manifold DN50	1
11	Hexagon nut M12	4
12	Washer 24 x 13 x 2.5mm	4
13	Gasket 95 x 60 x 2mm	1
14	Flange endcap DN50	1
15	Plug 1/2"	1
16	Hexagon screw M12 x 45mm	4
17	Threaded reducer	1

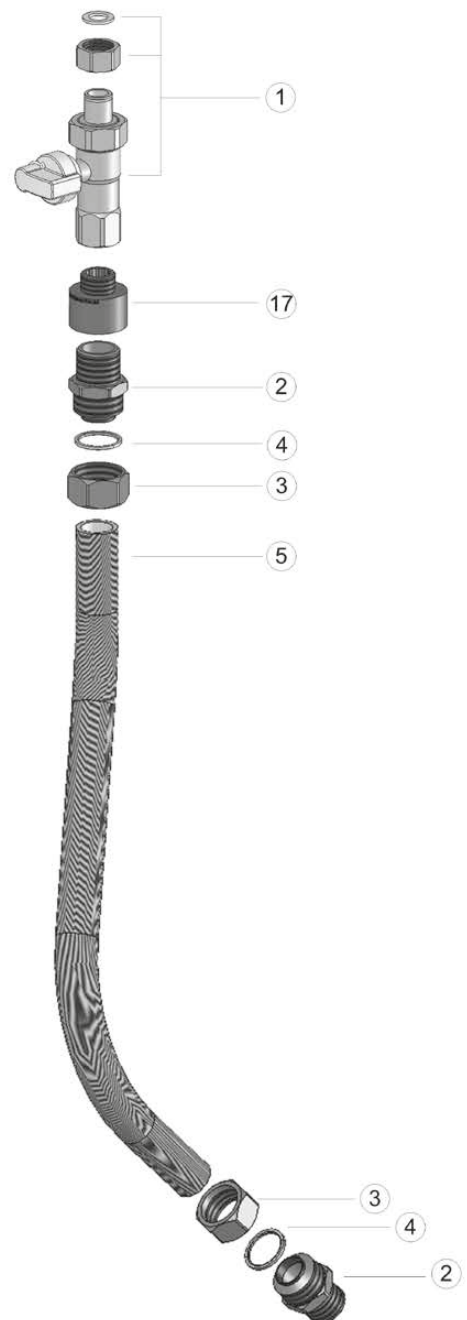

Accessories

Wall Hung Condensing Boilers

Gas fitting pack (130 & 150kW)

Number	Description	Quantity
1	Gas isolation valve 1"	1
2	Threaded Reducer 5/4"x1"	1
3	Reinforced gas hose DN32	1
6	Hexagon screw M8 x 20mm	2
7	Fix point gas manifold	2
8	Washer 8, 4 x 16 x 1.6mm	2
9	Hexagon nut M8	2
10	Gas pipe manifold DN65	1
11	Hexagon nut M12	4
12	Washer 24 x 13 x 2.5mm	4
13	Gasket 95 x 60 x 2mm	1
14	Flange endcap DN65	1
15	Plug 1/2"	1
16	Hexagon screw M12 x	4

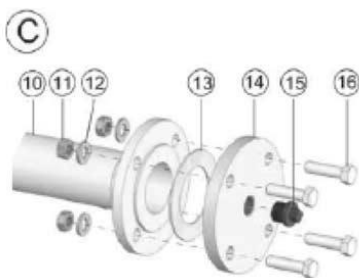
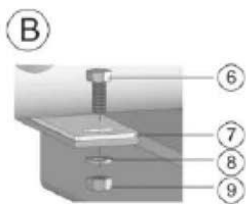
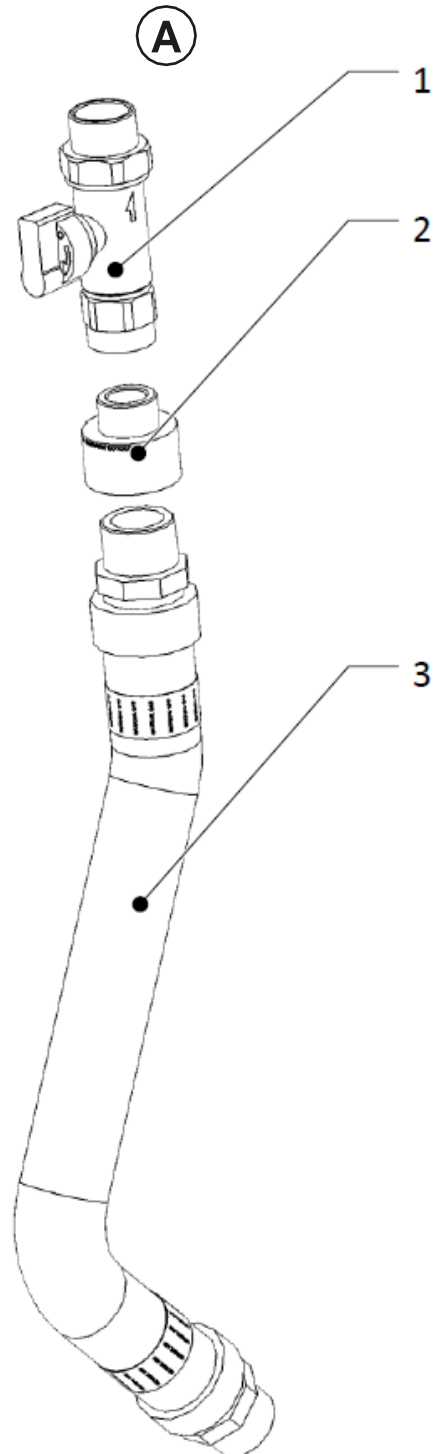

Assembly

Sirius three WH cascade boiler frame kits start with a two boiler module and all components are supplied within these kits to support an easy installation.

Steps 1 to 5;

1. Site the frame at the preferred location.
2. Attach the feet to the frame base. The feet are adjustable via a threaded screw and bolt arrangement. Please use the threaded adjustment on each foot with a spirit level to ensure the frame is evenly mounted. Bolt the frame to the floor through the pre-drilled holes in the foot plate for extra support.
3. Connect the manifold supporting brackets to the frame base using the supplied 8mm bolts and then attach the manifold pipes to the support brackets, again using the 8mm bolts supplied. The manifold pipes should have the tee connections for the boiler flow and return connections facing inwards towards the frame up-stand, as seen in the schematic
4. Fit the Victaulic end caps to the preferred end for the manifold terminations, leaving the “open” end clear to interface to the main system connections.
5. If required, fit the “S” stage bends to the manifold headers using the supplied Victaulic clamps, these “S” stage bends enable connection of the Low Loss Header.

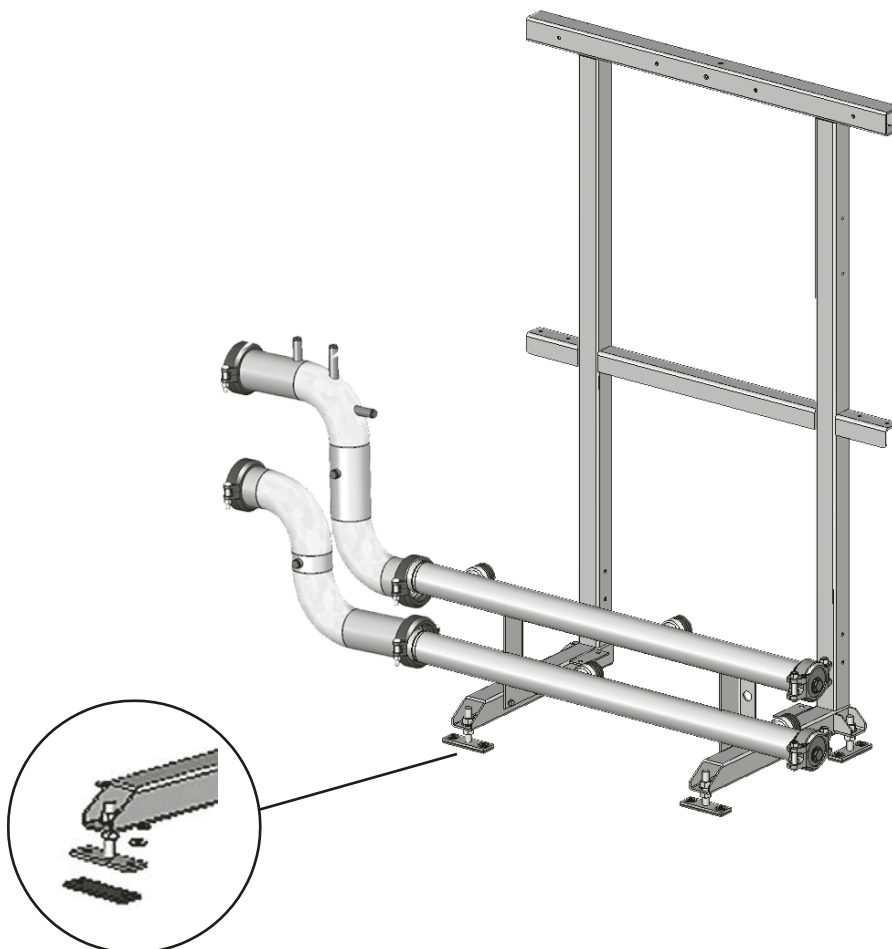

Assembly

Initial Frame

Sirius three WH cascade boiler frame kits start with a two boiler module but can be built up to create kits for 3, 4, 5, & 6 boilers.

The associated schematic shows the addition of a ½ frame kit to a 2 boiler frame. The additional ½ frame is bolted to the starter kit, thus enabling installation of a 3 boiler frame kit. When connecting a ½ frame for expanding the module please ensure to:

1. Attach the headers to the expansion module as per the basic module.
2. Align the expansion module using the supplied angle bracket and connection plate
3. Fit the feet to the base
4. Fit the end-caps to the expansion module end.

After connecting further modular frames as outlined above, please follow 2 to 5 on page 21 to complete the frame mounting.

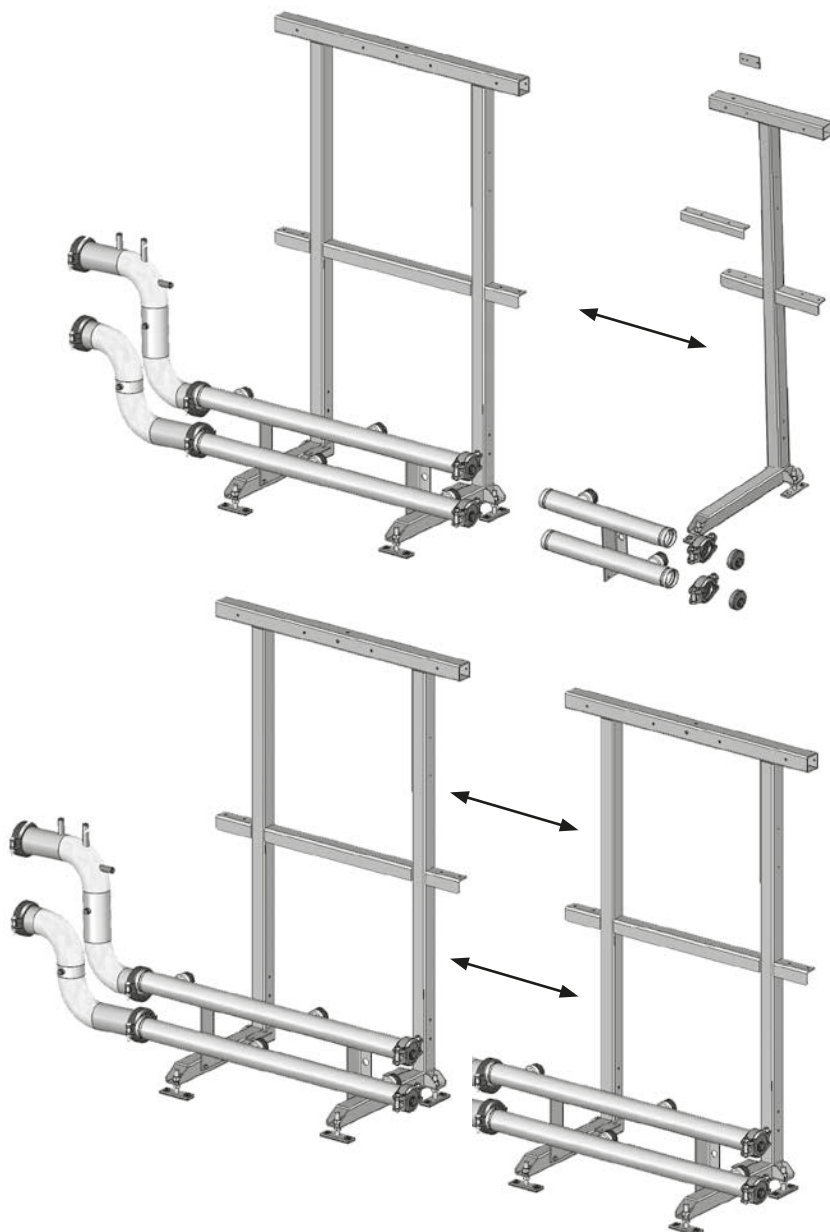

Assembly

Completion



Please refer to
page 4 for Manual
Handling guidance

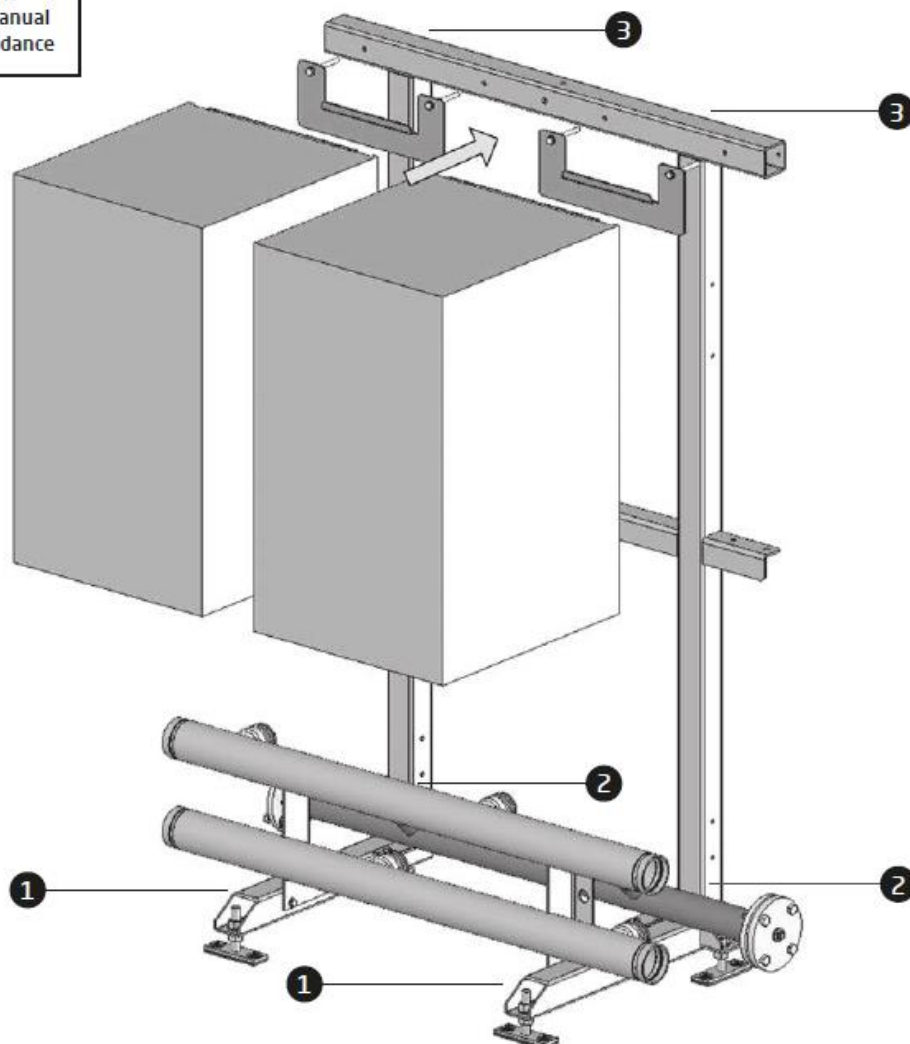

1. The manifold pipes that connect the boiler common flow and returns to the main system connection are a single piece, pre-fitted to a pair of brackets, that are to be bolted with the supplied bolts to the main frame. Please ensure that the tee connections for the boiler flow and returns are facing inwards towards the frame up-stand, as seen in the schematic
2. At this stage the gas manifold pipe can also be secured to the main frame
3. When mounting the boilers to the frame, the brackets supplied with the frame (not the boiler) are needed to hang the boilers securely. Please hang the brackets (supplied with the frame) using the nuts/bolts supplied, and attach to the pre-drilled holes, as shown on the image above. Tighten nuts/bolts to ensure they are load-bearing.

Assembly

Connection of the boiler flow

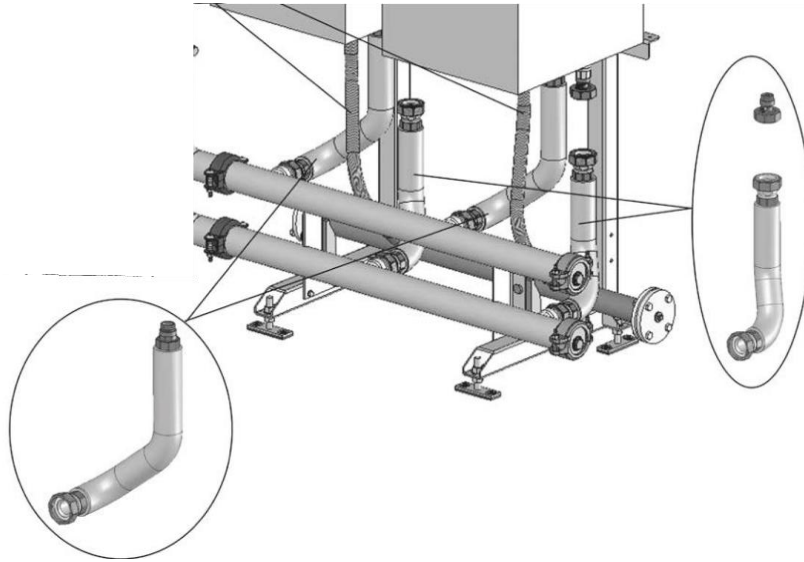

Assembling the flow connection: Please read this section in conjunction with page 18, 19 & 20 for exploded view drawings of the connection sets.

DN65 Flow set:

- 1 Attach the supplied boiler flow isolator valve to the boiler, (red handled screw threaded isolator valve).
- 2 Connect the 2" threaded nut (item 3) to the tee stub from the manifold pipe, ensuring the fibre gasket (item 1) is placed inside the fitting before connecting to the manifold connection.
- 3 Thread the insulated flexi flow pipe (item 9) on to the threaded end of fitting (item 2), making sure the rubber seal (item 5) is placed within beforehand.
- 4 Connect the brass reducer (item 7) to the flexi pipe (item 9), ensuring the seal (item 5) is inserted within the fitting prior to tightening.
- 5 Connect the available end of the flexi-pipe (item 9) to the boiler flow valve to finish the flow set fitting. Check all joints within the assembled connection ensuring all parts are fully tightened and secure.

DN100 Flow set: 90 & 110kW

- 1 Attach the supplied boiler flow isolator valve to the boiler, (red handled screw threaded isolator valve).
- 2 Connect the Victaulic clip (item 1) with rubber insert (item 2) loosely to the tee stub from the manifold pipe.
- 3 Thread the Victaulic brass fitting (item 3) in to (items 2 & 1) and fully tighten.
- 4 Insert gasket (item 4) to the Victaulic brass threaded connector and connect to the flexi pipe (item 11), then connect this pipe to the Victaulic fittings (items 1, 2 & 3).
- 5 The final connection involves securing the available end of the flexi pipe (item 9) to the boiler flow valve via brass fitting (item 12). Please make sure the rubber seal (item 4) is added inside the fitting.
- 6 Check all joints within the assembled connection ensuring all parts are fully tightened and secure.

Assembly

Completion

DN100 Flow set: 130 & 150kW

- 1 Attach the supplied boiler flow isolator valve (item 7) and T piece (item 14b) to the boiler, (red handled screw threaded isolator valve) ensuring gaskets (items 4 & 16) are in place before tightening.
- 2 Connect the Victaulic clip (item 1) with rubber insert (item 2) loosely to the tee stub from the manifold pipe.
- 3 Thread the Victaulic brass fitting (item 3) in to (items 2 & 1) and fully tighten.
- 4 Insert gasket (item 4) to the Victaulic brass threaded connector and connect to the flexi pipe (item 5b), then connect this pipe to the Victaulic fittings (items 1, 2 & 3).
- 5 The final connection involves securing the available end of the flexi pipe (item 5b) to the boiler flow valve via brass fitting (item 6). Please make sure the rubber seal (item 4) is added inside the fitting.
- 6 Check all joints within the assembled connection ensuring all parts are fully tightened and secure.

Assembly

Connection of the boiler return

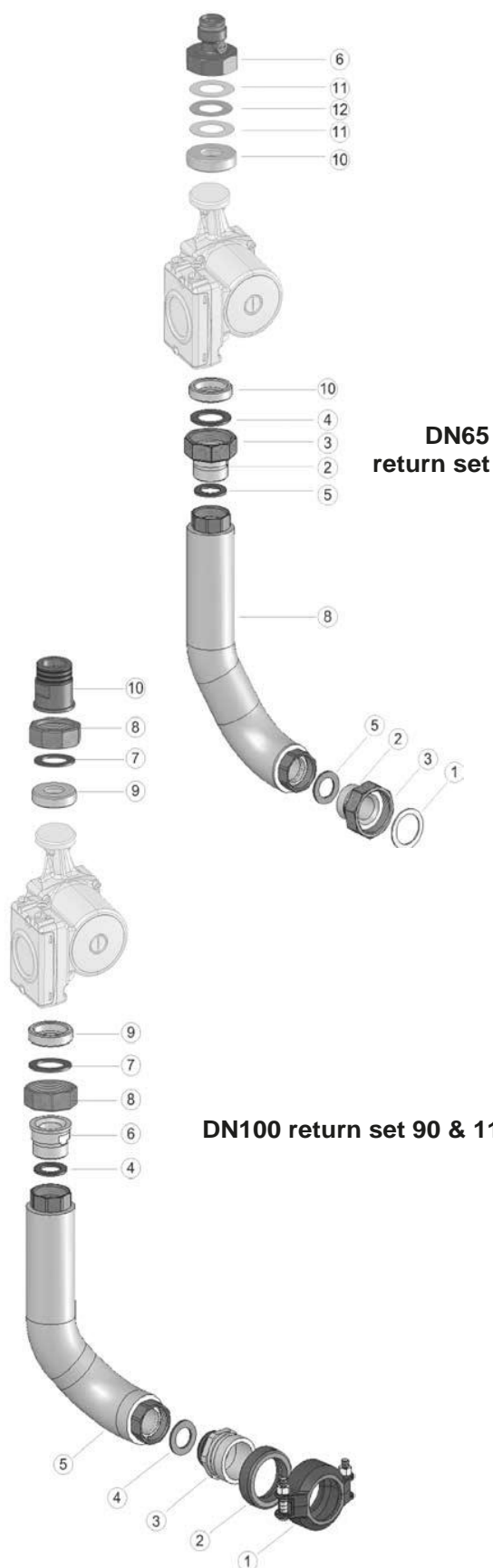

Please read this section in conjunction with pages 18, 19 & 20 for exploded views of the connection sets with a description table.

- 1 Attach the supplied boiler return isolator valve to the boiler, (blue handled screw-threaded valve).
- 2 Connect the primary circulator pump to the boiler return isolator valve ensuring the pump orientation is correct. The pump wiring will need connecting to the boiler PCB with the supplied flying lead.
- 3 When connecting the pump to the isolator valve, please pay careful attention to the fitting of the gravity break valve and associated seals and reducers.
- 4 Connect the Victaulic clip with rubber insert loosely to the tee connection from the manifold pipe, ensuring the fibre gasket is placed inside the fitting before connecting to the manifold connection. Be sure to apply some Victaulic grease, (supplied) to the rubber seal before assembly as this will aid the joint seal. Victaulic detailed instructions are also provided for your reference.
- 5 Insert a rubber washer to the Victaulic brass threaded connector and connect to the flexi pipe. Connect this pipe to the loosely fitted Victaulic clamp.
- 6 Fully tighten the securing bolts of the Victaulic clamp to ensure a robust seal.
- 7 Thread the insulated flexi flow pipe on to the threaded end of the Victaulic fitting, making sure the rubber seal is placed within beforehand.
- 8 The final connection involves connecting the threaded end of the flexi pipe to the boiler return isolator valve. Please make sure the rubber seal is added inside the fitting.
- 9 Check all joints within the assembled connection ensuring all parts are fully tightened and secure.

Assembly

Connection of the boiler return

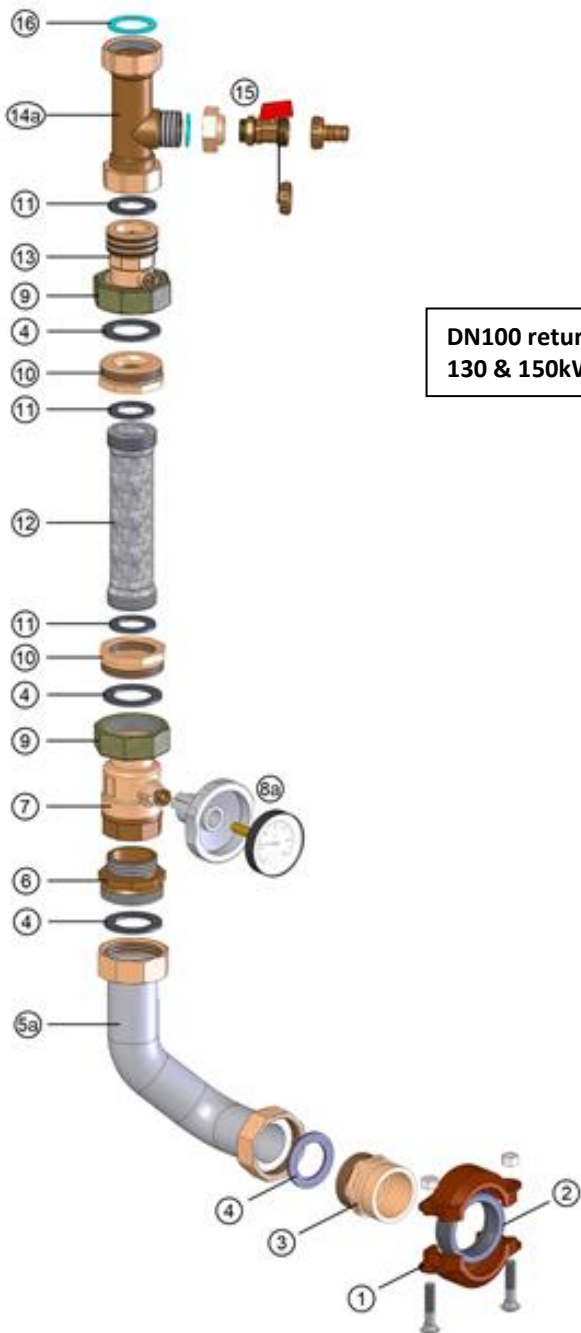

Please read this section in conjunction with pages 18, 19 & 20 for exploded views of the connection sets with a description table.

- 1 Attach the supplied T piece (item 14a) to the boiler, (fit drain valve item 15 to T piece) ensure gaskets are in place.
- 2 Fit Non return valve to T piece (item 13) and brass reducer (item 10) ensure gaskets are in place.
- 3 If the primary boiler pump is fitted inside the boiler casing (UPMXL 25-125 130) Connect the pump spool piece (Item12) to the brass reducer (item 10) ensure gaskets are in place.
- 4 Connect the boiler isolation valve (item 7) and brass reducer (item 10) to the pump spool piece and ensure gaskets are in place.
- 5 Connect brass bush (Item 6) to the boiler isolation valve using suitable jointing material (PTFE tape)
- 6 Connect the Victaulic clip with rubber insert (item 2) loosely to the tee connection from the manifold pipe, ensuring the fibre gasket is placed inside the fitting before connecting to the manifold connection. Be sure to apply some Victaulic grease, (supplied) to the rubber seal before assembly as this will aid the joint seal. Victaulic detailed instructions are also provided for your reference.
- 7 Insert a rubber washer (item 4) to the Victaulic brass threaded connector (item 3) and connect to the flexi pipe (item 5a).
- 8 Fully tighten the securing bolts of the Victaulic clamp to ensure a robust seal.
- 9 The final connection involves connecting the threaded end of the flexi pipe to the boiler return isolator valve. Please make sure the rubber seal is added inside the fitting.
- 10 Check all joints within the assembled connection ensuring all parts are fully tightened and secure.

Connection of the gas pipe (50 to 110kW boilers)

Assembly

Connection of the boiler return

1. Carefully unpack the Trac-pipe gas-pipe sub-assembly
2. Connect the gas manifold to the main frame assembly using the hexagonal screws and fittings (items 6, 7, 8 & 9 from drawing "B" below)
3. Determine which end of the gas manifold pipe will be capped off with the blanking plate in relation to the incoming gas supply to the frame system.
4. Assemble the end cap as per the exploded view drawing "C" (using items 10, 11, 12, 13, 14, 15 & 16).
5. Take a threaded cap nut (item 3) and place over one end of the Trac-pipe hose (item 5)
6. Place a split-ring set (item 4) within the fitted cap nut and pull the nut up to hold the split-ring in place
7. Thread the auto-flare fitting (item 2) in to the threaded nut (item 3), then attach the whole assembly in to the gas manifold pipe, (item 10)
8. Thread the yellow handled gas isolator valve (item 1) on to the gas connection on the boiler.
9. Take the remaining (item 3) threaded nut and place over the available end of the Trac-pipe hose, (item 5)
10. Place the split-ring (item 4) within the fitted nut and pull the nut up to hold the split-ring in place
11. Thread the remaining auto-flare fitting (item 2) in to the fitted gas isolator valve
12. The gas connection is now complete for one boiler, follow steps 5 to 11 for all remaining boilers.

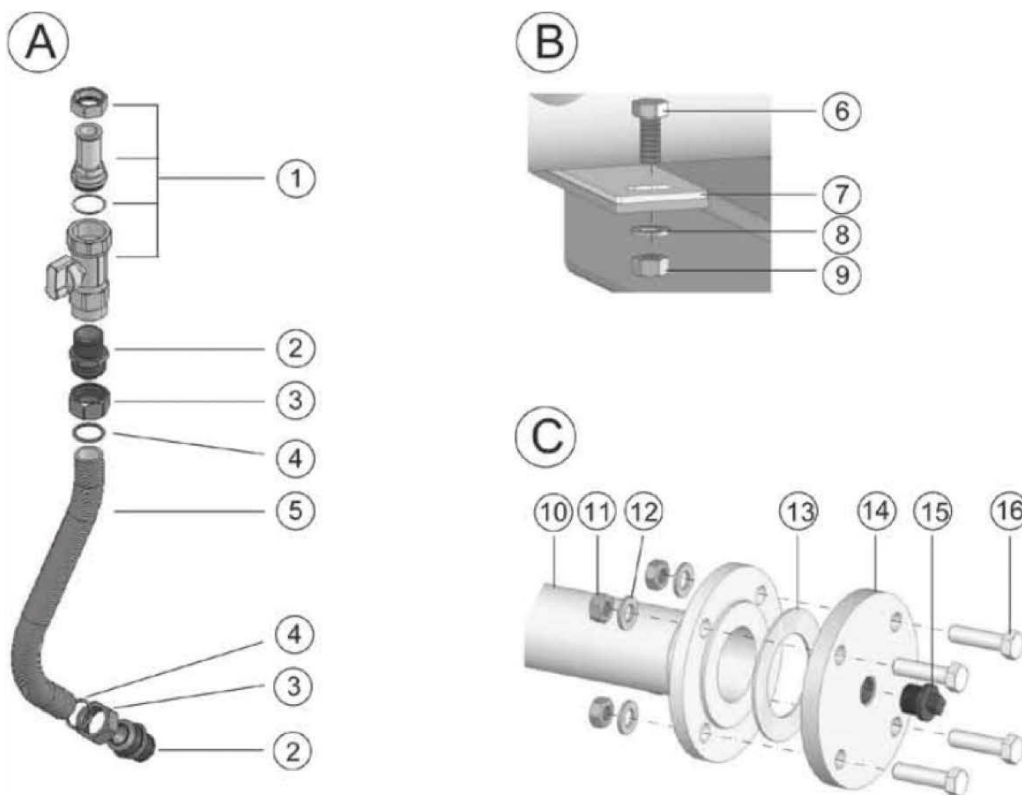

Please read the above in conjunction with Page 21.

Within the packaging of every 2 boiler Trac-pipe gas pipework kit, you will find a gas manifold DN50 PN6 end-cap and blanking plug. Please ensure this end-cap is fitted to the correct end of the gas manifold and securely tightened to prevent risk of gas leaks. (Steps 3 & 4 above and drawing "C").

Connection of the gas pipe (130 & 150kW boilers)

1. Carefully unpack the gas-pipe sub-assembly
2. Connect the gas manifold to the main frame assembly using the hexagonal screws and fittings (items 6, 7, 8 & 9 from drawing "B" below)
3. Determine which end of the gas manifold pipe will be capped off with the blanking plate in relation to the incoming gas supply to the frame system.
4. Assemble the end cap as per the exploded view drawing "C" (using items 10, 11, 12, 13, 14, 15 & 16).
5. Using gas approved jointing material connect the brass reducer (item 2) to the flexible gas hose (item 3)
6. Using gas approved jointing material connect the boiler gas isolation valve (item 1) to the brass reducer
7. Using gas approved jointing material connect the other end of the gas flexible hose to the gas manifold.
8. Using gas approved jointing material connect the gas valve union to the boiler connection then secure the gas valve.
9. Check to ensure all joints are tight.
10. The gas connection is now complete for one boiler, follow steps 5 to 10 for all remaining boilers.
11. Once the gas pipework is complete carryout a gas strength and soundness test as per IGE/UP/2

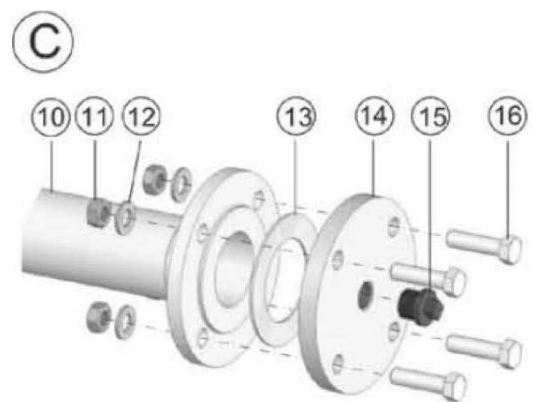
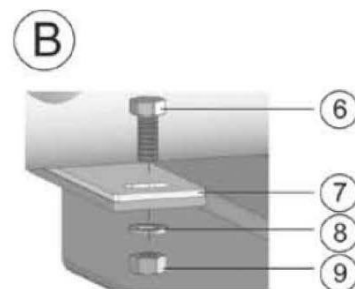
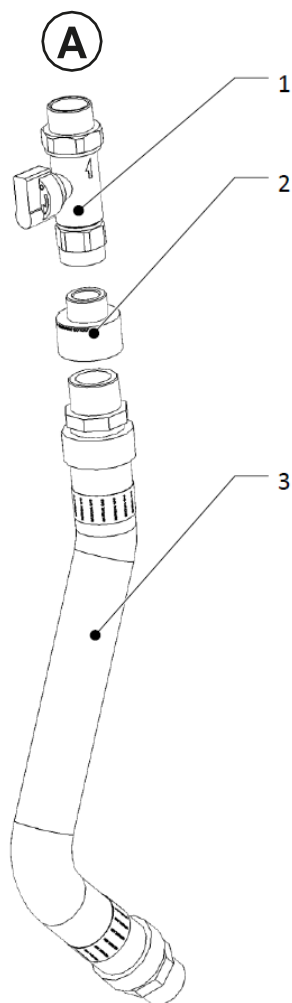

Please follow the above drawings to assemble the pieces of insulation supplied.

The numbers depicted on the drawings correspond to numbers in-printed on the inside of all insulation pieces.

 Please ensure you pressure test the gas and heat pipe system to ensure there is no leakage.

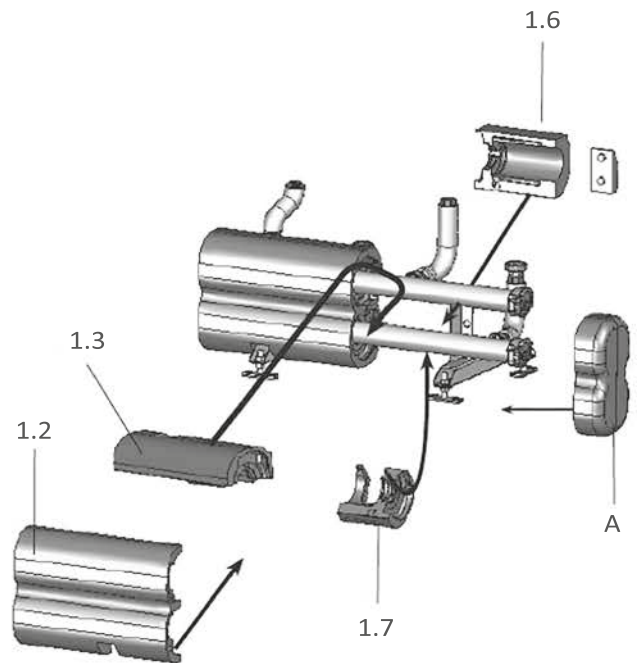
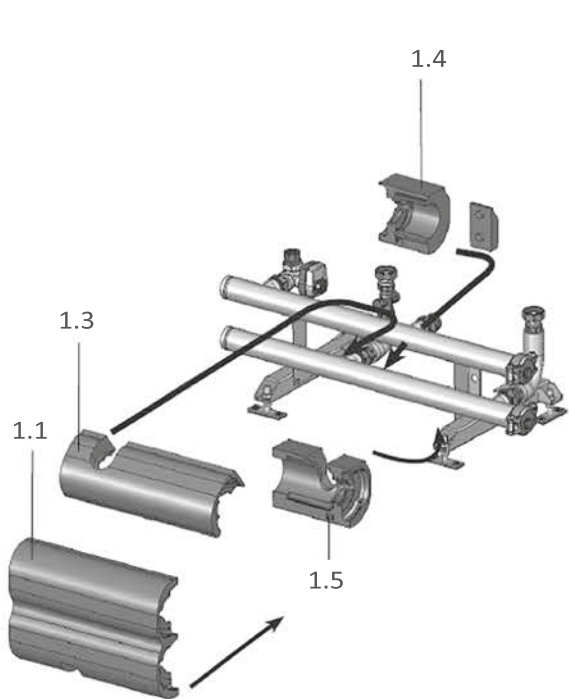
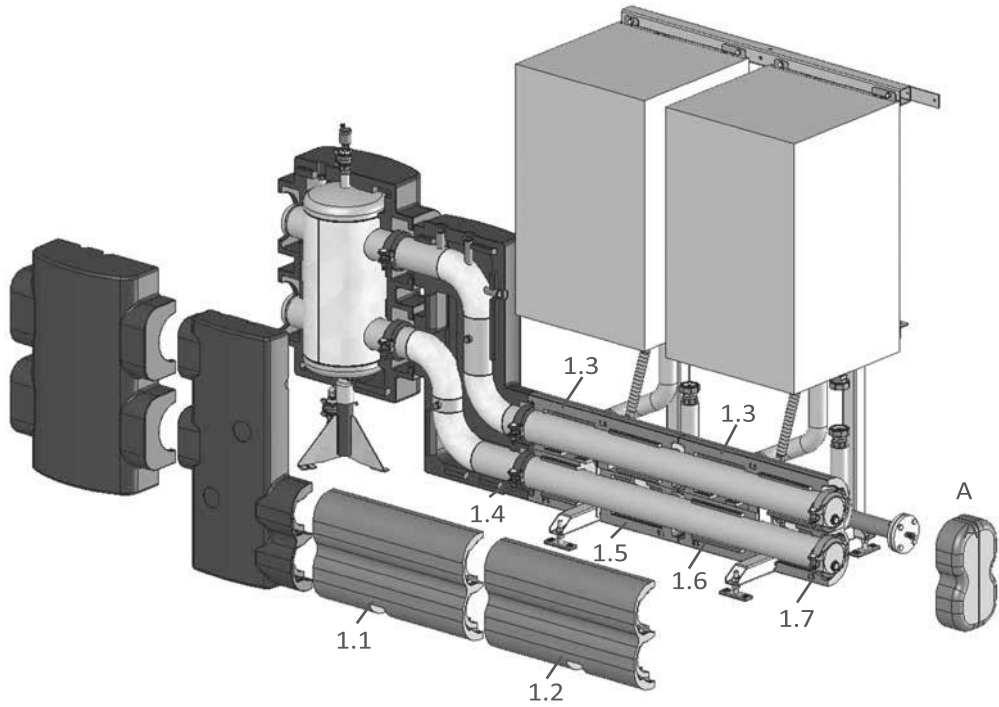

Options

In-line Cascade

Sirius two WH In-Line Cascade Frame Kit Options	Installation type																	
	2* 50Kw in-line	2* 60Kw in-line	2* 70Kw in-line	3* 50Kw in-line	3* 60Kw & 2* 90Kw in-line	4* 50Kw in-line	3* 70Kw in-line	2* 110Kw in-line	4* 60Kw in-line	3* 90Kw in-line	4* 70Kw in-line	3* 110Kw in-line	4* 90Kw in-line	4* 110Kw in-line	5* 90Kw in-line	6* 90Kw in-line	5* 110Kw in-line	6* 110Kw in-line
Max kW Output	100	120	140	150	180	200	210	220	240	270	280	330	360	440	450	540	550	660
Configurations																		
IN-LINE WITHOUT Low Loss Header	PART NO	CONFIG																
2x Sirius Pro (50, 60 or 70Kw models) in-line without Low Loss Header	5141019	●	●	●														
3x Sirius Pro (50, 60 or 70Kw models) in-line without Low Loss Header	5141020				●	●	●											
4x Sirius Pro (50, 60 or 70Kw models) in-line without Low Loss Header	5141021						●		●		●							
2x Sirius Pro (90 & 110Kw models) in-line without Low Loss Header	5141023					●		●										
3x Sirius Pro (90 & 110Kw models) in-line without Low Loss Header	5141024									●		●						
4x Sirius Pro (90 & 110Kw models) in-line without Low Loss Header	5141025												●	●				
5x Sirius Pro (90 & 110Kw models) in-line without Low Loss Header	5141026														●		●	
6x Sirius Pro (90 & 110Kw models) in-line without Low Loss Header	5141027															●		●
IN-LINE WITH Low Loss Header	PART NO	CONFIG																
2x Sirius Pro (50, 60 or 70Kw models) in-line with Low Loss Header	5141060	●	●	●														
3x Sirius Pro (50, 60 or 70Kw models) in-line with Low Loss Header	5141061				●	●	●											
4x Sirius Pro (50, 60 or 70Kw models) in-line with Low Loss Header	5141062						●		●		●							
2x Sirius Pro (90 & 110Kw models) in-line without Low Loss Header	5141064					●		●										
3x Sirius Pro (90 & 110Kw models) in-line without Low Loss Header	5141065									●		●						
4x Sirius Pro (90 & 110Kw models) in-line without Low Loss Header	5141066												●	●				
5x Sirius Pro (90 & 110Kw models) in-line without Low Loss Header	5141067														●		●	
6x Sirius Pro (90 & 110Kw models) in-line without Low Loss Header	5141068															●		●

Options

Corner group Cascade

Sirius two WH Corner Group Cascade Frame Kit Options	Installation type						4* 50Kw in-line	3* 70Kw in-line	2* 110Kw in-line	4* 60Kw in-line	3* 90Kw in-line	4* 70Kw in-line	3* 110Kw in-line	4* 90Kw in-line	4* 110Kw in-line	5* 90Kw in-line	6* 90Kw in-line	5* 110Kw in-line	6* 110Kw in-line		
	Max kW Output						200	210	220	240	270	280	330	360	440	450	540	550	660		
CORNER WITHOUT Low Loss Header		PART NO						CONFIG													
4x (2*2) Sirius Pro (50, 60 or 70Kw models) Corner Group without Low Loss Header	5141022						•			•		•									
4x (2*2) Sirius Pro (90 & 110Kw models) Corner Group without Low Loss Header	5141028													•	•						
5x (2*3) Sirius Pro (90 & 110Kw models) Corner Group without Low Loss Header	5141029															•		•			
6x (3*3) Sirius Pro (90 & 110Kw models) Corner Group without Low Loss Header	5141030																•		•		
6x (2*4) Sirius Pro (90 & 110Kw models) Corner Group without Low Loss Header	5141031																•		•		
6x (2*2*2) Sirius Pro (90 & 110Kw models) Corner Group without Low Loss Header	5141032																•		•		
CORNER WITH Low Loss Header		PART NO						CONFIG													
4* (2*2) Sirius Pro (50, 60 or 70Kw models) Corner Group with Low Loss Header	5141063						•			•		•									
4* (2*2) Sirius Pro (90 & 110Kw models) Corner Group with Low Loss Header	5141069													•	•						
5* (2*3) Sirius Pro (90 & 110Kw models) Corner Group with Low Loss Header	5141070															•		•			
6* (3*3) Sirius Pro (90 & 110Kw models) Corner Group with Low Loss Header	5141071																•		•		
6x (2*4) Sirius Pro (90 & 110Kw models) Corner Group with Low Loss Header	5141072																•		•		
6x (2*2*2) Sirius Pro (90 & 110Kw models) Corner Group with Low Loss Header	5141073																•		•		

Service and Maintenance

of the cascade frames is simple and trouble-free.

Elements for inspection and maintenance;

The system water should always be analysed to ensure the mix of chemical inhibitors and other system additives are at recommended and safe levels to protect the boilers and other equipment.

Before installing the boiler, the system must be cleaned and flushed to eliminate residual thread-cutting, swarf, solder and any solvents, using suitable off-the-shelf non-acid and non-alkaline products such as Sentinel X300 or Fernox F3 that do not damage metal, plastic and rubber parts. To protect the system from corrosion, sludge and scale, use inhibitors such as SENTINEL X100 and FERNOX protector for heating circuits. Use these products in strict compliance with the manufacturers' instructions.

The frame system should be visually inspected for any signs of damage or leaks – leaks will only occur from damaged or poorly made joints, these should be addressed immediately. Any damage should be reported to Baxi Commercial for advice.

Specifically, the Low Loss Header will need to be annually cleaned. This product is an integral air separator, dirt separator and magnetic filter optional.

For Low Loss Headers fitted with magnetic separators:

In order to clean, shut the closure caps of the magnetic separators are removed and the magnets are taken out. The magnetic impurities which have stuck will fall to the base and together with other impurities that have collected on the base can be flushed out through the drain tap.

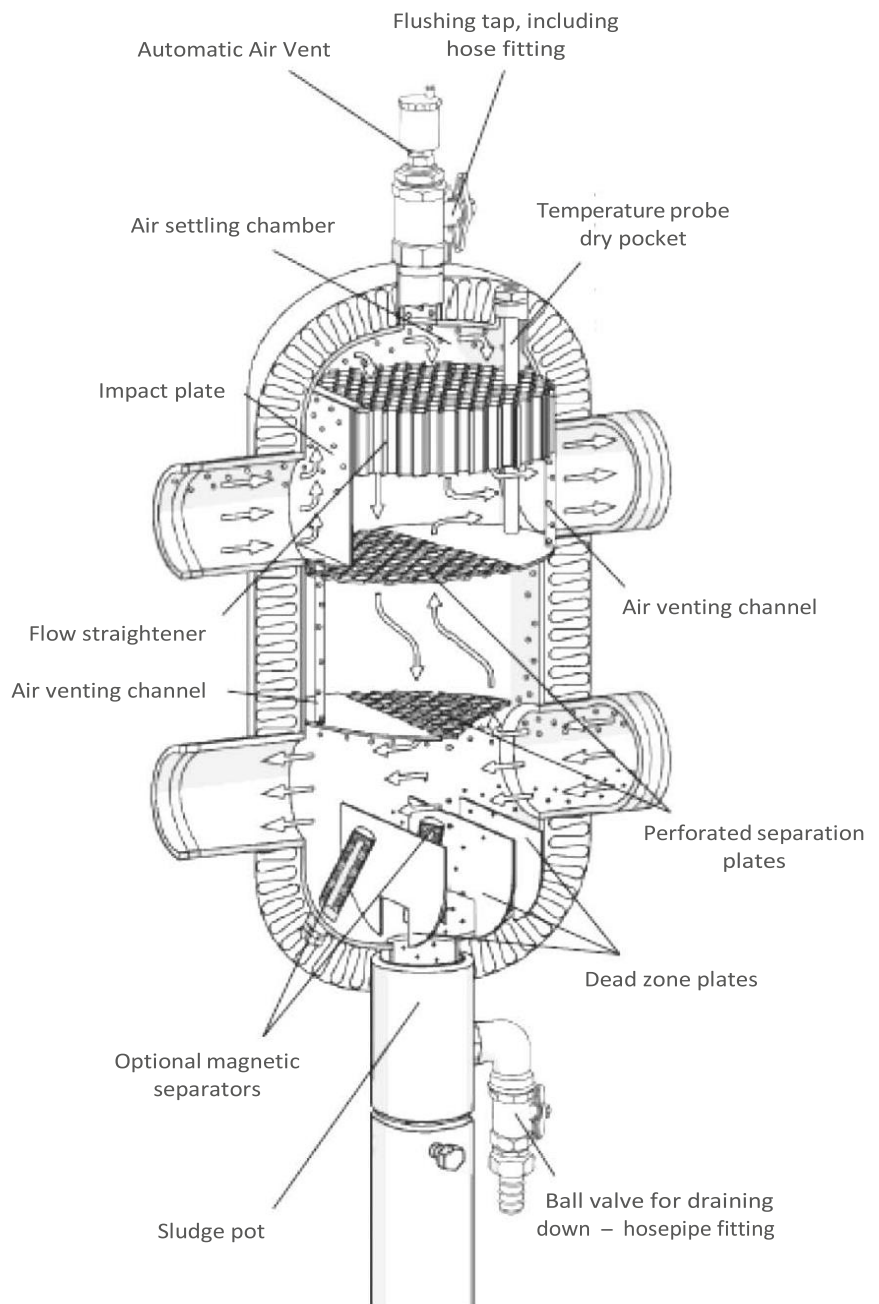



sales 0345 070 1055
technical 0345 070 1057
web pottertoncommercial.co.uk

Registered office address: Baxi Heating UK, Coventry Road, Warwick, CV34 4LL

June 2019

POTTERTON
COMMERCIAL

Totally dependable.

ALL TOGETHER BETTER



BAXI HEATING HAS A PORTFOLIO OF SOME OF THE BEST KNOWN AND MOST RESPECTED COMMERCIAL BRANDS IN THE HEATING INDUSTRY ACROSS THE UK AND IRELAND: • REMEHA, • ANDREWS WATER HEATERS, • POTTERTON COMMERCIAL AND • PACKAGED PLANT SOLUTIONS.

BAXI HEATING COMMERCIAL BRANDS



- **REMEHA** - ENGINEERING EFFICIENCY SINCE 1935
Reliably engineering high-performance and high-efficiency heating solutions.
- **ANDREWS WATER HEATERS** - BUILT TO PERFORM
UK's No. 1 commercial water heaters of choice for quality and reliability.
- **POTTERTON COMMERCIAL** - TOTALLY DEPENDABLE
Heating solutions that customers can rely on and services they can trust.
- **PACKAGED PLANT SOLUTIONS** - INGENUITY BOXED
Leading specialists in prefabricated plant rooms from concept to completion.