

C1/sfb
(C56.40) Xh1

May, 1987.

**ERECTION AND MAINTENANCE
INSTRUCTIONS FOR THE**

AVON TWO

CAST-IRON SECTIONAL BOILER



SECTION 1 – THE BOILER

Fig. 1 Dimensional Details.

ALL DIMENSIONS IN m.m.

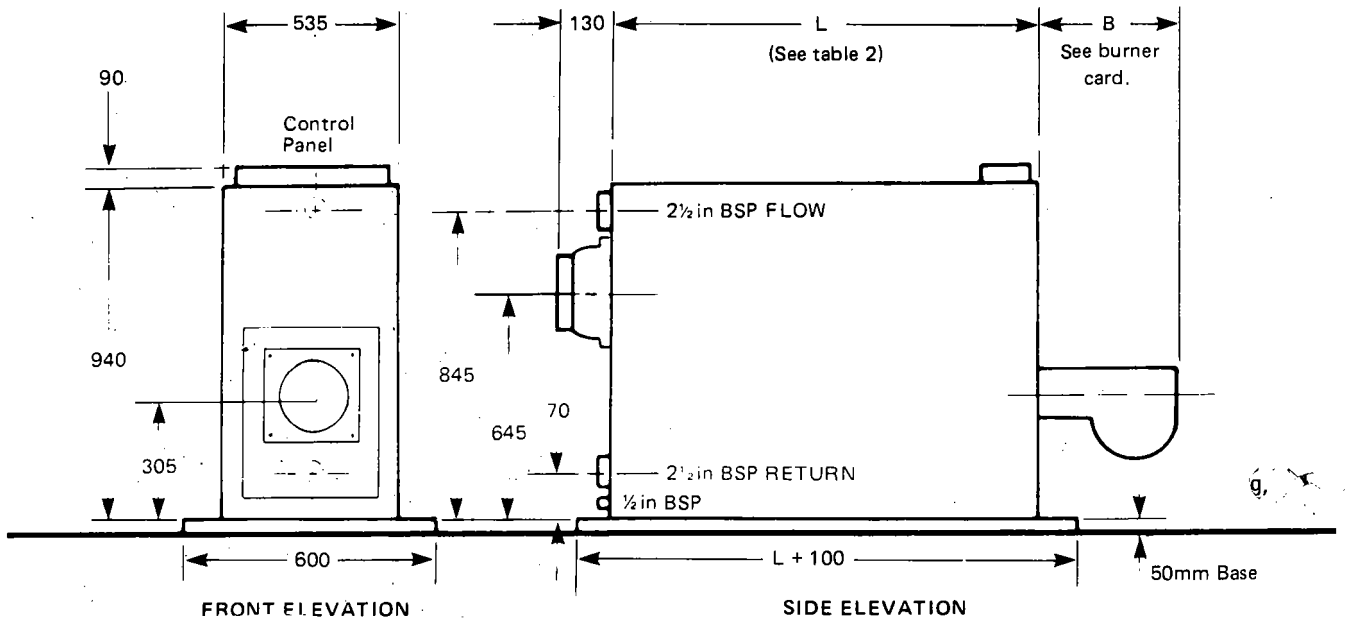

The safety valve and open vent must be connected to the system flow connection immediately off the back of the boiler.

Fig. 2 Avon Two Boiler Assembly

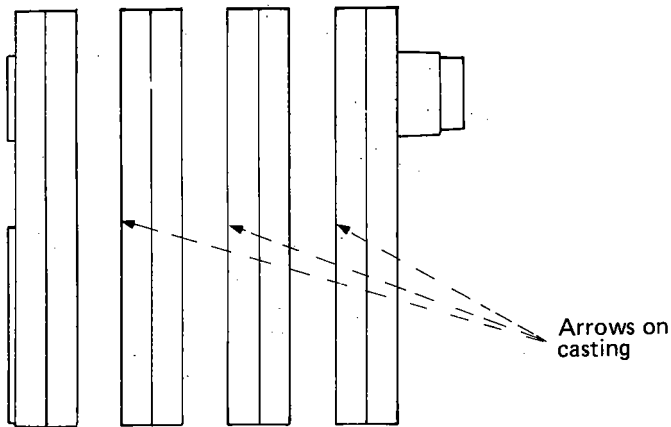
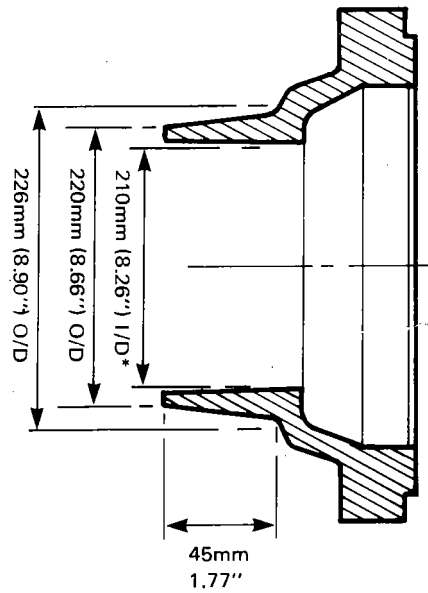
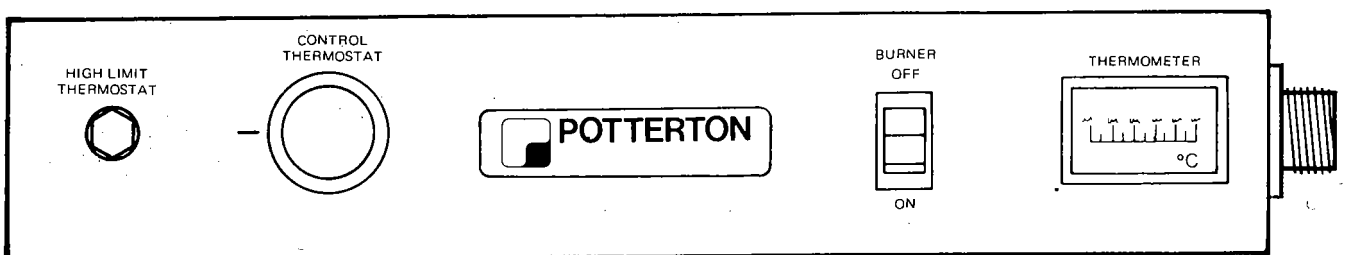

Fig. 3 Flue Outlet Connection



*NOTE: It is NOT advisable to use 8" I/D flue as no stop is fitted to prevent flue being pushed through nozzle into rear section.

FIG. 3 Instrument Panel Layout



General

The Avon Two is a compact sized, cast iron sectional boiler with low flue gas resistance.

Each section has a pipped heat exchange surface.

The sections are joined together with push taper nipples and tie bars.

The boiler is delivered to site unassembled for ease of handling, but it can be supplied assembled to special order.

Cast iron retarder plates are fitted between each section: these are short in length, 330mm, (12½ inches) and are fitted at the top of the boiler through the flue clean out openings.

A rigid enamelled steel casing is supplied packed separately and this includes 40mm of insulation fitted to the inner surfaces.

The boiler is supplied with a separately packed top mounted instrument panel. The panel includes control and limit thermostats, thermometer, on/off switch and mains indicator light. The instrument panel is supplied fully wired with a socket connection for simple burner connection.

The boiler is available with fully matched on/off oil or gas fired burners. These burners are to the latest B.S. and British Gas requirements where applicable and are suitable for burning 35 second oil or natural gas.

Burners for LPG, towns gas, and 28 second oil are available to special order.

M & E 3 specification, high/low, and dual fuel burners are also available.

No booster is required for natural gas firing if a gas pressure of 178mm w.g. (7" w.g.) is available under full load conditions at the inlet to the burner.

The burner is supplied fully wired with a flying lead and plug to allow plug in fitting to the socket on the instrument panel.

The Avon Two boiler is delivered to site in six packages.

1. Waterway Sections on a pallet.
2. Carton containing ancillary parts.
3. Burner carton.
4. Set of tie rods and U-Channels.
5. Set of assembly tools.
6. Casing and instrument panel pack.

Site Requirements

Access: The boiler sections will pass through a 762mm (30 in) doorway, as will all component parts.

Front and rear sections weigh approx. 77kg. (170 lb).

Intermediate sections weigh approx. 58kg. (130 lb).

Clearances

Front

1000mm (40 in) minimum from the front of the casing for boiler and burner maintenance.

Rear

Sufficient room must be allowed at the rear of the boiler to connect the flue.

Side

500mm (20 in) each side preferred for casing fitting and access for maintenance, although this can be reduced on one side only to 50mm (2 in).

For modular application the boilers can be positioned with a 50mm (2 in.) gap between, but provision must be made for top cleaning. For access, no more than three boilers should be installed in a bank. A gap of 500mm (20 in.) should be provided between banks of boilers.

Base

A level base is essential and it is recommended that this should be raised 50mm (2 in). No special insulated base is required other than that specified by Local Authorities and Building Regulations 1965. It is recommended that the boiler is erected on levelling strips positioned under the section feet. This is not essential, providing the floor finish is level; these strips are not provided.

Flue Connection

On all sizes of boiler the connection is sized 225mm (9 in) nominal, (See Fig. 2). The flue connection made onto the boiler flue outlet should be made with a slight angle upwards.

A square 90° bend must not be taken from this outlet; all flue bends off the boiler outlet to be 'easy sweep' pattern.

If an internally fitting fluepipe is to be used, it must NOT enter more than 40mm (1½ in.) into the boiler flue outlet connection.

Draught Requirements

The boiler flue should be capable of evacuating the volume of products from the boiler with a negative draught of 1 mm w.g. (0.04 in. w.g.) under running conditions.

A draught stabilizer should be fitted if draught exceeds 6mm (0.24 in. w.g.)

The boiler flue gas resistance is 2.5mm w.g. (0.1 in. w.g.) approx. under running conditions.

The proper evacuation of flue products is essential. C.P. 342 1970 Part 3 should be consulted to ensure adequate flue design. Reference should be made to the Clean Air Act and any local bye laws.

Both the flue connection from the boiler and the main chimney should be insulated where exposed to prevent condensation problems.

Fresh Air Requirements

Natural Ventilation

A permanent fresh air supply must be made available as close to the boiler as possible and at low level. This free area for ventilation must communicate directly with outside air. The grilles used should be of the 'low loss' type and must not be located in a position liable to blockage, flooding or an ingress of air from an inflammable process extraction.

If the boiler room is exposed it is desirable to have both high and low level air inlet grilles on at least two sides of the boiler room. High and low grilles must ALWAYS be on the same wall when only one external wall is used. The free air area is given for each size of boiler in Table 3. A high level vent of one half of this area is also required. See BS6644 : 1986 for details.

The ventilation areas given in table 3 are for a single boiler and are based on:-

Low level: 540cm² plus 4.5cm² for each kilowatt heat input in excess of 60kW.

High level: 270cm² plus 2.25cm² for each kilowatt heat input in excess of 60kW.

Mechanical Ventilation

For forced ventilation 0.90m³/s should be provided at low level and 0.60m³/s at high level for every 1000kW total rated heat input to the boiler house.

Forced inlet with natural ventilation at high level is permissible and the free area of the grill should be as given above.

Natural inlet and forced ventilation is not permissible.

For mechanical ventilation systems an automatic control should be provided to cut off the fuel supply to the boiler(s) in the event of failure of air flow in either inlet or extract fans.

The boiler will not operate correctly or efficiently if there is insufficient air for combustion and ventilation.

System Requirements

Maximum operating temperature

90°C (194°F)

Maximum working head

55m (180ft.) – 5.4 bar (78 p.s.i.)

Minimum working head

3m (10ft.) – 0.3 bar (4.5 p.s.i.)

The maximum temperature drop across the boiler must not exceed 25°C (45°F) under normal running conditions.

This is to minimise undue strains and stresses on the boiler.

The minimum return temperature should not drop below 55°C (131°F) under normal running conditions.

The pressure drop through the boiler with a temperature difference between flow and return of 11°C (20°F) is as shown in Table 1.

The minimum working head may be reduced to 2m (6ft.) provided that the boiler is not operated above 82°C (180°F). The limit thermostat must be set to operate at 95°C under this condition.

**TABLE 1 Pressure Loss Through Boiler For
11 deg C (20 deg F) Temperature Differential**

BOILER	mm	in.
5	54	2.0
6	85	3.5
7	122	5.0
8	165	6.5
9	216	8.5
10	273	11.0
11	338	13.5
12	450	18.0

It is recommended that where multiple boilers are installed, a minimum flow rate of 10% of normal flow rate based on 11°C rise should be maintained for the off cycle boiler. The minimum flow rate for on cycle boiler must not create greater than 25°C rise.

Water Quality

Water treatment is not necessary provided the raw water hardness content does not exceed 100 ppm, the TDS level (salinity) is not excessive and assuming there are not water losses from the system, then significant amounts of scale formation or corrosion deposits will not be formed in the system. If these parameters are not fulfilled then it is strongly recommended that you approach a reputable specialist Water Treatment Company who will recommend the correct method of dealing with scale formation, corrosion and microbiological fouling.

Noise Level

Detailed figures are available on request for all types of burners specified, but as a guide only, the noise level is N70 for gas burners and N65 for oil burners under typical operating conditions.

Electrical Supply

Single phase, 220/240 volts, 50 Hz, 3 wire supply connected via a double pole isolator and suitable fuses, supplied by the installer.

TABLE 2 – Leading Dimensions

BOILER TYPE No. of Sections	OUTPUT		DIMENSION L		WEIGHT EMPTY		WEIGHT FULL		FUEL CONSUMPTION				FLUE GAS VOL. AT S.T.P.	
	kW	Btu/h (approx.)	mm	in (approx.)	kg	lb (approx.)	kg	lb (approx.)	OIL		GAS		m ³ /h	ft ³ /h
									L/h	Imp g/h	m ³ /h	ft ³ /h		
5	72	250,000	665	26	327	720	393	870	8.49	1.87	8.66	306	134.8	4760
6	90	310,000	790	31	385	850	463	1020	10.61	2.33	10.82	382	167.1	5900
7	108	370,000	915	36	443	980	533	1180	12.74	2.80	12.99	459	199.4	7040
8	126	430,000	1040	41	501	1100	603	1330	14.86	3.27	15.15	535	231.8	8185
9	144	490,000	1165	46	559	1230	673	1480	16.98	3.74	17.32	612	264.1	9325
10	162	550,000	1290	51	617	1360	743	1640	19.11	4.20	19.48	689	296.5	10470
11	180	620,000	1415	56	675	1490	813	1790	23.23	4.67	21.65	764	334.2	11800
12	200	680,000	1540	61	733	1620	883	1940	23.59	5.19	24.06	849	366.6	12950

Fuel consumption based on 80% efficiency for 35 sec. oil, and 78% efficiency for natural gas. Flue gas volume based on 10.5% CO₂ (oil) or 8% CO₂ (gas) equivalent to 45% excess air at the above efficiencies and standard temperature and pressure. Flue gas temperature at flue outlet socket is approximately 235°C (450°F).

TABLE 3 – Fresh Air Requirements

BOILER REF.	HIGH LEVEL FREE AREA		LOW LEVEL FREE AREA		
	MINIMUM		MINIMUM		
	cm ²	in ²	cm ²	in ²	
Avon Two	5	343	53	685	106
	6	395	61	790	122
	7	446	69	893	138
	8	498	77	997	154
	9	550	85	1100	170
	10	602	94	1205	188
	11	654	102	1308	204
	12	712	110	1424	220

SECTION 2 – BOILER ERECTION

Preparation

Before commencing erection, check that all the parts shown on the packing sheets are on site.

Erection Procedure

Waterways

1. Stand the rear section upright in its working position and prop it up with a plank. The two water connection flanges should be facing rearwards. Starting with rear section, the intermediate sections must be assembled in accordance with the directions of the arrows pointing towards the front of the boiler. (See Fig. 2, page 2).
2. Thoroughly clean the nipples and the nipple sockets; remove any rough burrs with a file if necessary. Wipe both nipples and nipple sockets clean. Apply red nipple coating compound to the outside face of each nipple and insert them into the top and bottom nipple sockets on the rear section.
3. Apply a bead of sealing adhesive in the outer groove round the section, the 'U' shaped groove under the centre flueways and the groove under the top nipple port. Apply the three strips of sealing rope (4mm diameter) into these grooves.
4. Clean the nipple sockets on both faces of the first intermediate section as described in 2. above.
5. Position the intermediate section adjacent to the rear section and engage the upper nipple socket onto the nipple already fitted to the rear section. Then gently engage the lower socket over the lower nipple. The nipples should fit sufficiently into the nipple sockets to support the intermediate section.
6. Insert the assembly rods through each of the top and lower nipple holes. Fit the nuts and clamps where they protrude at the rear of the boiler. The rear projection should be no longer than 150mm (6 in).
7. Fit the clamp and nuts to the other end of the rods and screw down the nuts until they tighten against the clamp which in turn tightens against the intermediate section. The final tightening, to pull the two sections firmly together, must be done evenly so that uniform pressure is applied to the nipples and the flue gas seals between the two sections. Tighten sufficiently so that there is a metal to metal seal between the sections. This can be achieved without straining on the assembly tools.

WARNING

When tightening the assembly rod, do not stand directly in front of the nut or at the rear of the boiler. This is especially important when tightening the final sections.

8. Smooth over the adhesive sealing compound that will have squeezed out between the two sections. This will have to be repeated after tightening each section in turn. It is essential to ensure there are no leaks from the flue gas side.
9. Check that the two sections are upright and that the rear section is aligned with the flow and return pipe-work and flue system, where applicable.
10. Unscrew the assembly nuts and withdraw the rods from the top and lower nipple holes.
11. Prepare the next intermediate section, then position and tighten as previously described.

NOTE:

Always ensure the nipples and sockets are clear of burrs and are adequately coated with jointing compound. Similarly, it is essential to correctly fit the rope flue gas seal. Incorrect fitting will mean a strip down and re-build.

12. Always erect and tighten one section at a time, taking care to tighten evenly. Pulling up more than one section is NOT recommended.
13. The front section is fitted in the same way as the intermediate sections.

14. When all the sections have been erected and the assembly tools withdrawn, the tie rods are fitted. These tie rods are located two at the top and two at the bottom of the boiler either side of the nipple ports. Pass the rods through the lugs on the front and rear sections. Screw the nuts onto each end of all four tie rods, using the washers provided. The tightening of the tie rods is usually carried out from the front of the boiler once the four nuts have been tightened at the rear.

CAUTION:

It is essential to tighten the rods progressively in a diagonal sequence (as when tightening a car wheel) to ensure an even tightening. A torque wrench, although not essential, will ensure even tightening of the rods and a maximum torque of 80 N.m (60 lb. ft.) should be applied. However, common sense should tell the erector when the nuts are tight enough. Do not strain or overtighten.

15. When the boiler has been erected and the tie rods fitted, check to ensure that all sections are sealed and the boiler is level. Position a spirit level on the tie rods to check this.

Platework

1. Fit the two door hinges using the four M8 x 30mm (1¼ in) knurled Allen headed thumbscrews. Fit the door on to the hinges. Screw the one M12 x 75mm (3 in) stud into the front section, close the door and secure with an M12 nut and washer.
2. Screw four M12 x 35mm (1½ in) long studs into the four tapped holes adjacent to the flow and return tappings at the top and bottom of the rear section. Fit a screwed counterflange using the M12 nuts, washers and gasket, to each tapping.
3. Position the sight glass gasket in the viewing hole in the front of the boiler, and fit the sight glass. Secure using the circlip supplied.

Baffle Plates and Flue Cover Plates

1. Slide the flue baffle plates between the sections, ensuring the baffles are fitted in every flueway.
2. Place one white ceramic fibre pad over each flueway clean out hole.
Fit a 'V' shaped cover plate over each pad, with the point of the 'V' pointing downwards and secure in position with a spring clip. See Fig. 6.

N.B. Some boilers may be supplied with two ceramic pads per flueway clean out hole. In this case a different design spring clip is provided. The two pads should be fitted and secured as above. See Fig. 7.

If during maintenance it is necessary to replace flue pads, two pads should be refitted if there were two originally. It is essential that the flueway clean out holes are correctly sealed to prevent leakage of flue gasses.

Casing and Instrument Panel

1. Locate the thermostat/thermometer pocket in the ½ in. BSP tapping on the top of the rear section.
2. Ensure that any spare tappings in the waterway are plugged, and that all fittings are tight.
3. Place the U-Channels (supplied strapped to the pulling up tools) either side of the boiler.
When each corner panel and insulated side panel is fitted ensure that the bottom of the panel fits into the U-Channel.
4. Starting at the front right hand side of the boiler, take a corner panel that has no integral fixing clips on its edge and position it over the lugs on the front section. There are two corner panels with integral fixing clips and two without per boiler. Ensure that the cut out in the side of the panel is at the bottom.
5. Take an insulated side panel and slot it into position on the corner panel. Ensure that the corner notches for the casing top panels are at the top.

6. Repeat operation 5, as necessary, using a combination of panels as dictated by the boiler size.
7. Before fitting the rear corner panel, position the R.H. rear panel such that it locates between the lugs on the rear of the boiler. Then attach the corner panel, so trapping the rear panel in position.
8. Position the L.H. rear panel and join to the R.H panel using the self-tapping screws in the holes provided.
9. The left hand side of the casing is fitted in a similar manner to the right hand side, but starting at the rear, using a corner panel that has no integral fixing clips on its edge.
10. Fit the front cover panel onto the studs on the front inspection panel and secure with the capped nuts. Ensure that the insulation does not obscure the inspection hole.
11. Connect the mains electricity supply lead into the instrument panel in accordance with the instructions under 'Electricity Supply.' Pass the lead through the cut-out in the left hand side of the panel, securing with a suitable cable termination.
12. Take the blanket of silver foil backed fibre glass insulation and place on top of the boiler.
13. Take the smaller of the two top casing panels with the three knockouts and knock out the larger 50mm diameter hole.
14. Take the control panel and uncoil the two thermostat and thermometer capillaries.
15. Thread the capillaries through the three holes in the lower sealing plate (flat side down) and seal with the three split grommets provided. See Fig. 8.
16. Fasten the control panel to the top casing panel with the two screws provided sandwiching the sealing plate
17. Fit the top panel and control panel. On the 11 and 12 section boiler the control panel should be positioned over the second intermediate section.
18. Insert the two thermostat and thermometer phials into the thermostat pocket in the rear section. Take care not to kink the capillaries and secure with the spring spacer between the phials and secure with the spring clip.
19. Fit the remaining top panel.
20. For boilers with high/low burners fix the black PVC conduit supplied strapped to the pulling up tool to the side of the casing with self tapping screws not supplied by Potterton International Limited.

This conduit is for the high/low thermostat plastic armoured electrical connection to run through. This thermostat is prewired to the burner by a 2.0 m connection by the burner manufacturer.

The conduit is 1.5m long and will have to be trimmed to length.

Burner

1. Fit the burner and gasket to the mounting plate using the M12 x 33mm nuts and bolts provided, then fit the plate to the hinged boiler front door using the M8 x 25mm studs and nuts. The burner mounting plate fitting will be dependent on the burner being used.
2. Plug the burner electrical connection into the socket at the RHS of the instrument panel and screw up the knurled ring to secure the plug.
3. For high/low burners the high/low thermostat is prewired to the burner by a 2.0m connection. The thermostat which is complete with a 4" long ½ " BSP pocket should be fitted into the flow pipe work as near to the boiler as possible.

The plastic armoured flexible connection to the thermostat should run through the black PVC conduit as described in item 20 under "Casing and Instrument Panel".

Connecting the Fuel Supplies

Oil Supply

1. Run the oil supply pipe, minimum size ¾ in. BSP, so that it terminates with a valve, close to the burner. Fit the ¼ in. BSP oil filter (packed in the burner carton) to the supply line and connect it to the burner using the length of flexible hose supplied (packed in the burner carton).
2. On a two-pipe system, remove the plug from the port at the bottom of the pump and fit the by-pass plug, supplied in a plastic container attached to the burner, screwing it fully home. Run the return pipe into the port. In two-pipe systems, a spring-loaded non-return valve should be fitted in the return pipe as close as possible to the oil pump, and a foot valve on the suction pipe in the oil tank (see British Standard Code of Practice CP 3002 Part 1 1961 - Installation Burner Class D Fuel Oil). It is recommended that a hand valve, not supplied, be fitted at the inlet to the filter.
3. If a return pipe is fitted this should be connected with flexible hose. A separate isolating valve may be fitted for easy removal of the burner equipment.
4. For further details, see burner manufacturers instructions.

Gas Supply

The Local Gas Region should be consulted at the installation/planning stage to establish that an adequate supply is available. An existing service pipe must not be used without prior consultation with the Local Gas Region. A meter of suitable capacity must be connected. Existing meters should be checked to ensure they are adequate. Installation of pipes should be in accordance with CP 331.3. The complete installation must be tested for soundness as described in the above Code.

A minimum gas pressure (working) of 17.5 mbar (7" wg) must be available at the gas inlet.

The gas connection size to the burner is as detailed on the burner card. For further details, see burner manufacturers instructions.

Electric Supply

All on-site electrical wiring should conform to the I.E.E. Regulations for buildings and Local Authorities requirements.

1. Check that the mains supply is 220 - 240 volts a.c. 50 Hz single phase. The final 500 to 750 mm (20 to 30 in.) of the cable should be enclosed in flexible conduit for easy movement during maintenance and a double pole isolating switch and suitable HRC fuse should be incorporated in the electricity supply line.

NOTE:

All isolating switches, fuses etc. must be supplied by the installer. They are not supplied by Potterton International Ltd.

2. The boiler is supplied complete with pre-wired instrument panel. The incoming electricity supply should be connected to terminals 1 and 2 on the terminal strip, Live to 1, Neutral to 2 and Earth to 6. The supply lead should be fed into the panel via the knock out in the left hand end of the panel, and secured with a suitable cable termination.

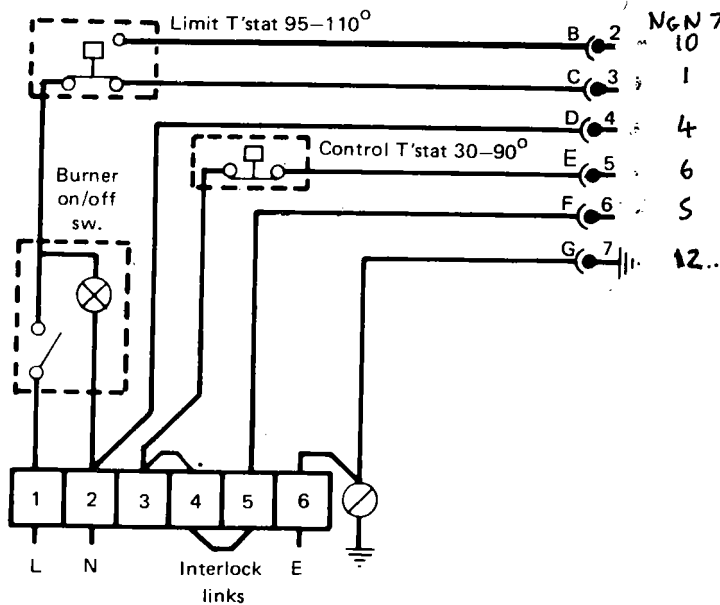

NGN 789 + NDF + NOL
 10
 1
 2
 3
 4
 5
 6
 7
 12..

NGS 25
 6
 2
 3
 4
 1

Fig. 5 Instrument Panel Wiring

Fig. 6 Flueway Clean Out Hole Sealing

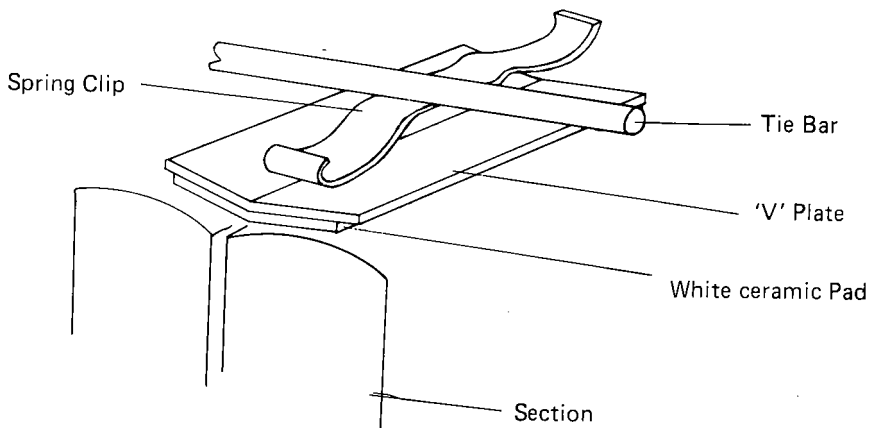
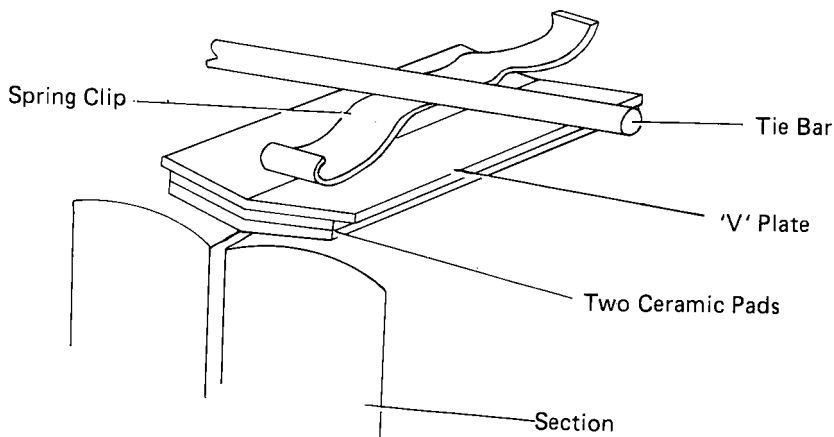

Fig. 7 Flueway Clean Out Hole Sealing.



N.B. With two sealing pads a plain flat plate may be supplied instead of a 'V' plate.

External Controls

Time – Clock	The time clock can be wired into the control circuit by removing the interlock link and connecting between terminals 4 and 5.
Pump –	The pump can be switched by the time clock via a relay operated from the switched side of the time clock and a separate L.N and E supply to the pump.
Pump – Overrun	If the system design is such that, due to residual heat within the boiler, nuisance trip of the limit thermostat may occur, then in accordance with good practice, consideration should be given to the fitting of pump overrun thermostats. This can be incorporated by using a 'break on fall' immersion or 'strap on' thermostat positioned in the flow pipework adjacent to the boiler, set at say 60°C. This thermostat should be wired in parallel with the pump relay contacts.
Low Limit Protection	The simplest method of providing frost protection for the boiler and system is to wire in parallel with the time clock contacts an outside air temperature thermostat, set to call for heat whenever the outside air temperature falls below 2°C.
Remote – limit trip indicator	A remote limit trip indicator or warning device may be wired by taking a live lead from terminal 3 on the overheat thermostat via the indicator and back to a suitable neutral supply, for instance terminal 2 on the panel. Access to the overheat switch is described in section 5 A (2) "To set the cut-off temperature". The indicator should be designed to work on 250 volts A.C.

SECTION 3 – COMMISSIONING

Commissioning

The burner should be set up to give the optimum operation as recommended below. Please refer to the burner manufacturers installation instructions enclosed with the burner for detailed information on burner adjustment. The boiler/burner unit should give the following flue gas analysis under normal working conditions on a clean boiler.

Oil	
CO ²	– 11-12%
Smoke	– 0 – 1 Bacharach
Flue Gas Temp.	– 230-250°C (450-485°F)
Draught	– 1 mm – ve

Gas	
CO ²	– 8-9%
O ²	– 4-5%
CO	– nil
Flue Gas Temp.	– 200-230°C (390-450°F)
Draught	– 1 mm – ve

To obtain a true analysis of the flue gas sample, suitable measuring equipment must be used. A sampling hole should be made in the flue close to the flue offtake. Switch the boiler on for a minimum of 30 minutes before taking readings.

SECTION 4 – MAINTENANCE

General

It is essential for efficient and trouble free operation, that the boiler plant is regularly maintained. This must be carried out by qualified and experienced engineers and this facility is available from Potterton International Ltd., details are available from the Regional offices listed on the back page of this manual.

It is strongly advised that a maintenance contract be entered into with Potterton International Limited to ensure that the boiler/burner unit is correctly and properly maintained.

Frequency of boiler cleaning varies and is dependent on fuel, site conditions, heat load, design of controls, running conditions, and hours of use, but should not be less than once per year for gas and twice per year for oil.

WARNING: Isolate the electrical and fuel supplies before attempting any maintenance work.

Burner Maintenance

The burner must be regularly serviced and maintained in accordance the burner manufacturers instructions provided with the burner.

Cleaning of Flue Surfaces

For the maximum efficiency and economy in running, it is essential that the combustion chamber and flueway surfaces should be kept clean and free from deposits. A layer of deposits 1/16 in. (2mm) thick will reduce the heat transfer through the wall by up to 10%. Not only does this waste fuel, but the higher flue gas temperatures which result will increase the thermal stress within the boiler and may lead to joint leakage or, in extreme cases, to section failure.

After removing the top panels from the casing detach the spring clips securing the flueway covers and remove these together with the sealing strips taking care not to damage the strips. Remove the baffles from the flueways. It is essential that cleaning is carried out throughout the full length of the flue passes and that all debris is removed from the combustion chamber via the front door and inspection cover.

Reassemble in the reverse order making sure that a good gas-tight joint is made by the sealing strips under the flueway covers.

SECTION 5 – INSTRUMENTS

A. Limit Thermostat Type "Landis & Gyr" RAK 21.3121.1. Part No. 354436

- (1) To Reset the Thermostat
 - (a) Remove the BLACK hexagonal cap, see Fig.3.
 - (b) Press GREEN button GENTLY downwards until the thermostat snaps back to the closed contact condition.
 - (c) Replace the cap.
- (2) To Set the Cut Off Temperature
 - (a) Ensure that the electricity supply to the boiler is switched off.
 - (b) Lift off the casing front top panel, complete with the control panel.
 - (c) Unscrew the two screws from below and remove the control panel.
 - (d) From the front of the control panel, remove the BLACK Hexagonal cap and the lock-nut below it, this will free the thermostat from the panel.
 - (e) Set the pointer on the front face of the thermostat to the desired cut-off temperature. The thermostat is delivered pre-set to 95°C but, this may be increased to 110°C depending upon system head.

Fig. 8

AVON TWO CONTROL PANEL FIXING

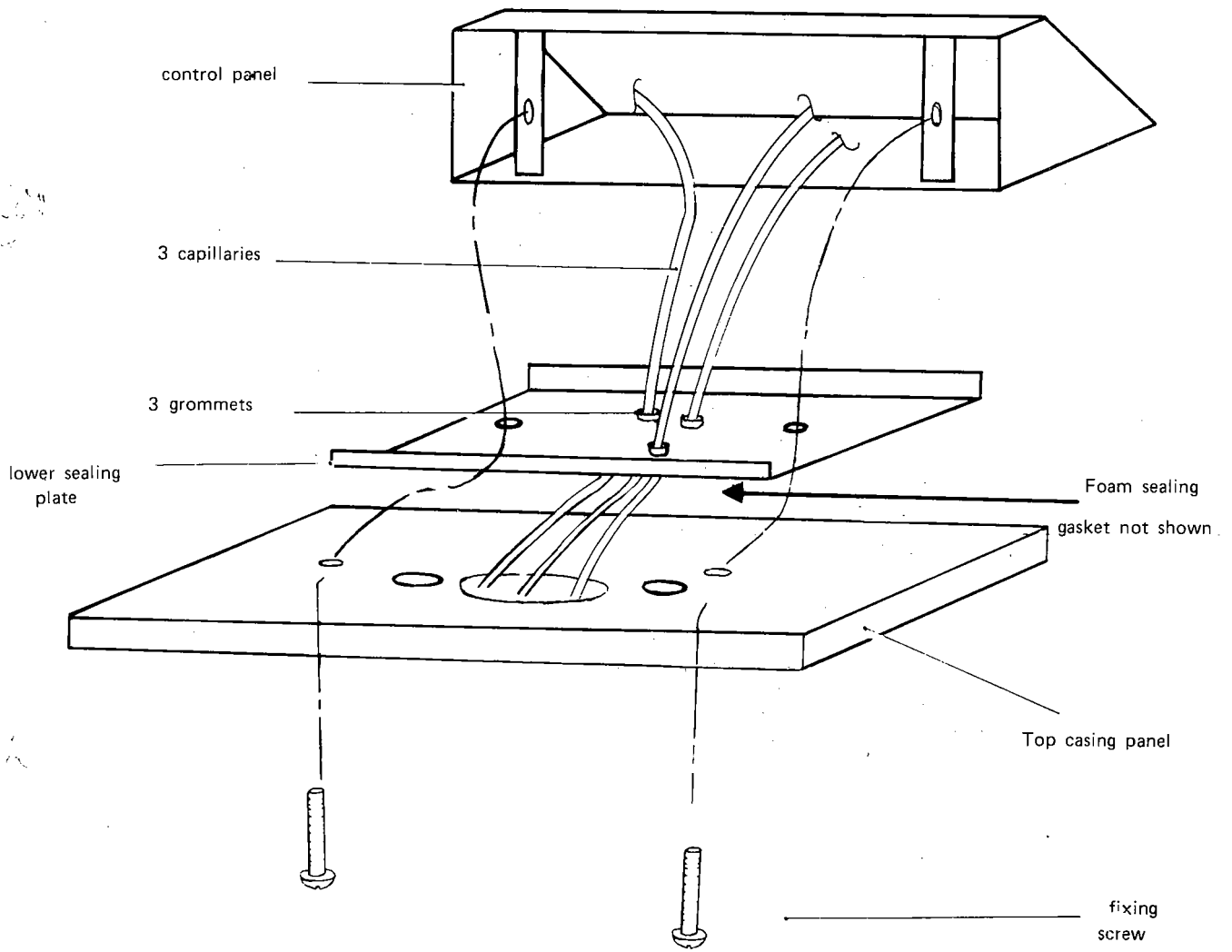

- (f) Refit the thermostat, then the control panel and the casing top panel.
- (3) To Replace the Thermostat
 - (a) Ensure that the electricity supply to the boiler is switched off.
 - (b) Lift off the casing front top panel, complete with the control panel.
 - (c) Unscrew the two screws from below and remove the control panel.
 - (d) From the front of the control panel, remove BLACK hexagonal cap and the locknut below it; this will free the thermostat from the panel.
 - (e) Remove the remainder of the boiler casing top panels.
 - (f) Remove the spring clip from the flats of the hexagonal top of the combined thermostat/thermometer pocket, then, remove the phial of the overheat thermostat.
 - (g) Pull off the electrical connection tags from the thermostat body (terminals "1" and "2").
 - (h) When replacing, take great care not to kink or otherwise damage the capillary tube, especially where it enters the pocket, then press all three phials fully home into the pocket before replacing the clip. Reconnect the electrical leads.
 - (i) Fit the thermostat to the control panel, fit the panel to the casing front top panel and finally fit all the casing top panels in position.

**B. Control Thermostat Type "Landis & Gyr"
RAK24/4011/1, Part No. 354435**

This thermostat is pre-calibrated and is not capable of being re-calibrated on site.

- (1) To Replace the Thermostat
 - (a) Ensure that the electricity supply to the boiler is switched off.
 - (b) Lift off the casing front top panel, complete with the control panel.
 - (c) Unscrew the two screws from below and remove the control panel.
 - (d) Remove the remainder of the boiler casing top panels.
 - (e) Remove the spring clip from the flats of the hexagonal top of the combined thermostat/thermometer pocket, then withdraw the phial from the pocket.
 - (f) Pull off the thermostat knob and remove the two screws now exposed, this will free the thermostat and its bezel.

- (g) Pull off the electrical connection tags from terminals "1" and "2".
- (h) When replacing, take great care not to kink or otherwise damage the capillary tube, especially where it enters the pocket.
- (i) Press all three phials fully home into the pocket before replacing the clip. Re-connect the electrical leads.
- (k) Fit the thermostat to the control panel making sure that the special stop screw is at the top.

**C. Thermometer Type "Landis & Gyr"
QAN3011/1, Part No. 354437**

This thermometer is pre-calibrated and is not capable of being re-calibrated on site.

- (1) To Replace the Thermometer
 - (a) Ensure that the electricity supply to the boiler is switched off.
 - (b) Lift off the casing front top panel, complete with the control panel.
 - (c) Unscrew the two screws from below and remove the control panel.
 - (d) Remove the remainder of the boiler casing top panels.
 - (e) Remove the spring clip from the flats of the hexagonal top of the combined thermostat/thermometer pocket, then withdraw the phial from the pocket.
 - (f) From the back of the panel press inwards the two plastic clips at the top and bottom of the thermometer body casing and push the unit out through the front of the panel.
 - (g) Replace the thermometer by passing the phial and the capillary through the opening in the panel from the front and press inwards until the clips snap into place.
 - (h) When replacing, take care not to kink or otherwise damage the capillary tube especially where it enter the pocket.
 - (j) Press all three phials home into the pocket before replacing the clip.
 - (k) Fit the panel to the casing front top panel and finally fit all the casing top panels in position.

WARNING:

Isolate the electrical and fuel supplies before attempting any maintenance work.

"All descriptions and illustrations contained in this leaflet have been carefully prepared but we reserve the right to make changes and improvements in our products which may affect the accuracy of the information contained in this leaflet"

POTTERTON A member of the
INTERNATIONAL LIMITED



Group of companies

COMMERCIAL PRODUCTS DIVISION

Sales and Administration:
Service:

Depot Lane, Emscote Road, Warwick. CV34 5QB Tel: 0926 493420, Telex 31668
Atlas House, Chorley Old Road, Bolton, Lancs. BL1 4JR Tel: 0204 46524
10 Hardwicks Way, London S.W.18 4AJ Tel: 01 870 5278

Publication No. 558949/0587

NU-WAY GAS BURNER INFORMATION

AVON TWO - SECTIONS		5	6	7	8	9	10	11	12	
OUTPUT	KW BTU/HR x 10 ³	72 250	90 310	108 370	126 430	144 490	162 550	180 620	200 680	
NU-WAY BURNER TYPE	ON/OFF SPEC. NUMBER	NGN3 S22-550B	NGN5 S22-553S	NGN5 S22-553S	NGN7 S20-036Z	NGN7 S20-036Z	NGN7 S20-036Z	NGN8 S20-003H	NGN8 S20-003H	
FULLY CLOSING AIR DAMPER		←----- OPTIONAL -----→								
NU-WAY BURNER TYPE	HIGH/LOW SPEC. NUMBER	-	-	-	NGN7 S20-037S	NGN7 S20-037S	NGN7 S20-037S	NGN8 S20-023U	NGN8 S20-023U	
FULLY CLOSING AIR DAMPER		←----- STANDARD -----→								
FIRING RATE (HIGH)	m ³ /hr	8.66	10.82	12.99	15.15	17.32	19.48	21.65	24.06	
POWER REQUIREMENTS	MOTOR KW	0.25	0.25	0.25	0.25	0.25	0.25	0.25	0.25	
240V 1PH 50HZ - START CURRENT	AMPS	7	7	7	7	7	7	7	7	
	- RUN CURRENT	AMPS	1.7	1.7	1.7	1.7	1.7	1.7	1.7	
CONTROL BOX	ON/OFF	←----- MMI 810 -----→								
WIRING DIAGRAM	ON/OFF	←----- WA4-7461 -----→			←----- WA2-7542 -----→					
CONTROL BOX	HIGH/LOW	←----- TMG-740 -----→								
WIRING DIAGRAM	HIGH/LOW	-	-	-	←----- WA1-7544 -----→					

NOTE

Commissioning should be carried out by qualified, experienced engineers. This facility is available from Potterton International Ltd, Commercial Service Office. See back page for details.

COMMISSIONING - GAS - NUWAY

Full details of the procedure for the initial commissioning of the burner are given in the Technical Data manual packed by the manufacturers with each burner and these instructions should be carefully followed. The following summary may be found useful.

Ensure that fuel is available at the plant isolating valve and confirm that the fuel type, including supply pressure is suitable for equipment supplied.

With gas and electrical supplies isolated, check that the draught tube, gas nozzle, diffuser and electrodes/probes are to the specification shown and check that the settings are correct.

The following outline procedure described is for standard on/off burners. For high/low burners the gas rate and air flap must be set and combustion checked on both high and low flame settings (see burner manufacturers instructions, ie. high/low burner commissioning).

With the main and pilot gas cocks shut, open the service gas cock and purge the gas line thus ensuring that gas is available to the burner.

With all services on set the burner air flap to the position indicated and select pilot gas only. Allow the burner to run through its sequence. Check establishment of pilot flame.

NGN 3/5 BURNER DIMENSIONS

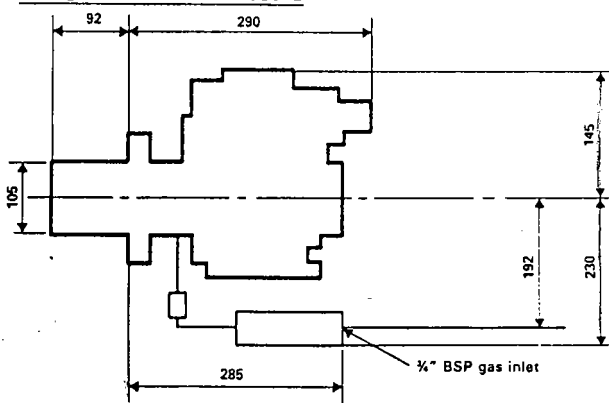

Using the gas meter check that pilot gas rate is in accordance with burner manufacturers recommendations. It is recommended that a micro ammeter is used and that ionisation probe currents on both pilot and main flame are checked to be in accordance with the burner manufacturers guidelines.

Having established pilot flame correctly, switch the burner off and select main and pilot gas and switch the burner back on. Allow the burner to run through its sequence to main flame establishment.

Using the gas meter check the main gas rate to ensure that the burner unit is operating at full boiler rated output. The burner head gas pressure may be used as a guide to gas rate on main flame (see table). Check combustion performance when the boiler is up to its design temperature which should be as follows: - CO₂: 9%, CO: <100 ppm, nett flue gas temperature less than 250°C, draught in excess of 1mm wg-ve. Adjust air shutter and burner settings as necessary to give optimum combustion performance.

Check that the thermostats operate correctly by adjusting each in turn to a temperature below that of the boiler/system water.

Check that the control box goes to "lockout" when the probe current circuit is interrupted. If for any reason the burner cannot be commissioned satisfactorily refer to the burner manufacturers instructions and follow the fault finding procedure if necessary.

Commission the closed position indicator switch on the NG8 burner.

Allow the boiler/burner unit to run for approximately 30 minutes and re-check combustion. Ensure that the boiler/burner unit is left fully commissioned and operating safely and correctly.

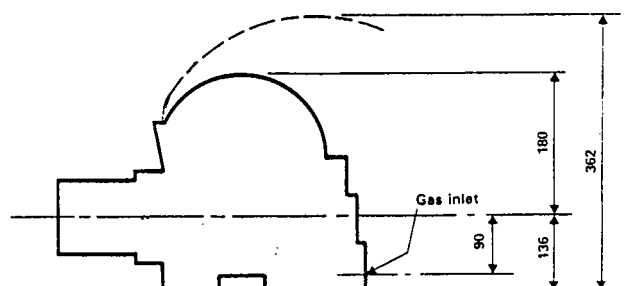

NGN 7/8 BURNER DIMENSIONS

DIMENSIONS

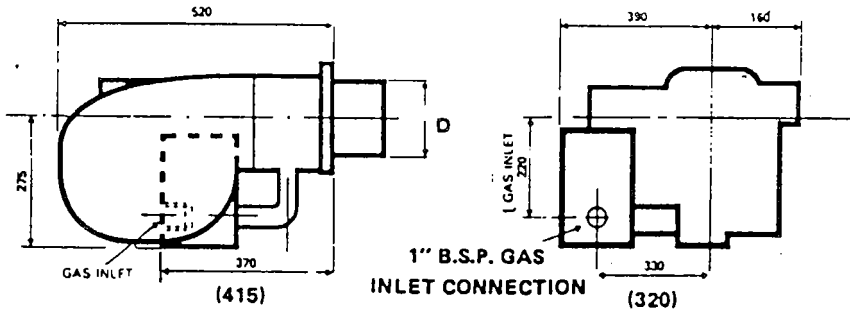

Gas train shown is a Dungs multiblock valve without pilot line for on/off burners only.

Figures in brackets are for high/low burners using a Landis & Gyr SKP70 combined valve/governor/air fuel ratio control and with a separate pilot line.

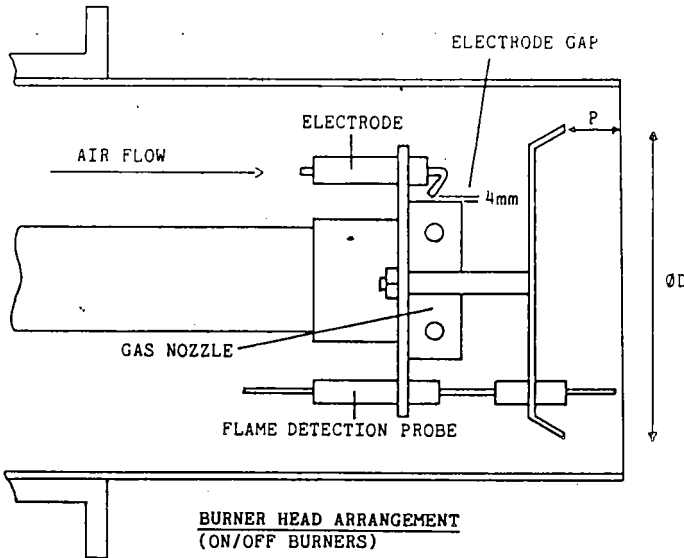

BURNER HEAD ARRANGEMENT (ON/OFF BURNERS)

* On/Off Burners do not have pilot gas tube.

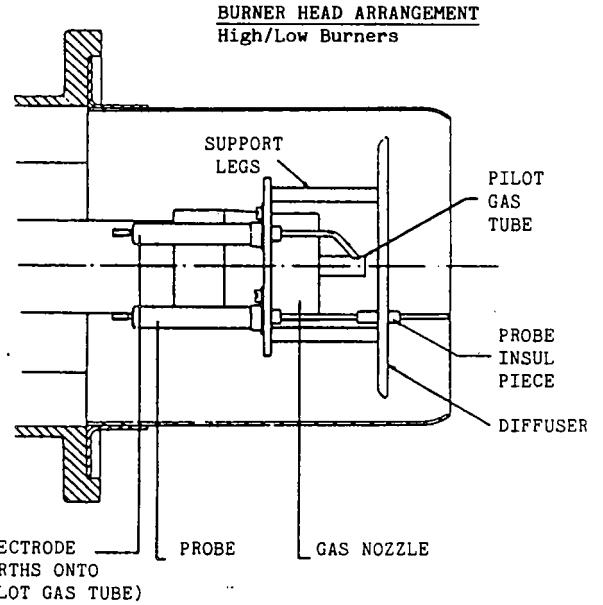

BURNER HEAD ARRANGEMENT High/Low Burners

BOILER SECTIONS	BURNER MODEL	DRAUGHT TUBE DIAMETER	DRAUGHT TUBE PROJECTION	DIFFUSER POSITION	GAS NOZZLES				BURNER HEAD GAS PRESSURE Approx				AIR DAMPER SETTING		DIFFUSER DIAMETER
					END		SIZE		HIGH		LOW		HIGH	LOW	
					No.	Dia	No.	Dia	In.wg	mm.wg	In.wg	mm.wg	% OPEN	% OPEN	
5	NG3	105	92	32	5	3.0	5	3.0	4.2	106	-	-	13mm open	-	95/25
6	NG5	105	92	32	5	4.0	5	4.0	3.2	81	-	-	6mm open	-	85/25
7	NG5	105	92	32	5	4.0	5	4.0	4.0	102	-	-	11mm open	-	85/25
8	NG7	105	100	32	5	2.5	5	5.0	3.0	75	1.7	43	30	10	85/25
9	NG7	105	100	32	5	2.5	5	5.0	3.3	84	2.0	52	40	10	85/25
10	NG7	105	100	32	5	2.5	5	5.0	4.4	111	1.8	46	60	15	85/25
11	NG8	133	100	25	8	3.0	8	5.0	2.4	60	1.2	30	50	20	110/13
12	NG8	133	100	25	8	3.0	8	5.0	2.9	73	1.2	30	50	10	110/13

BURNER WIRING CONNECTIONS

(See boiler erection manual for boiler connections)

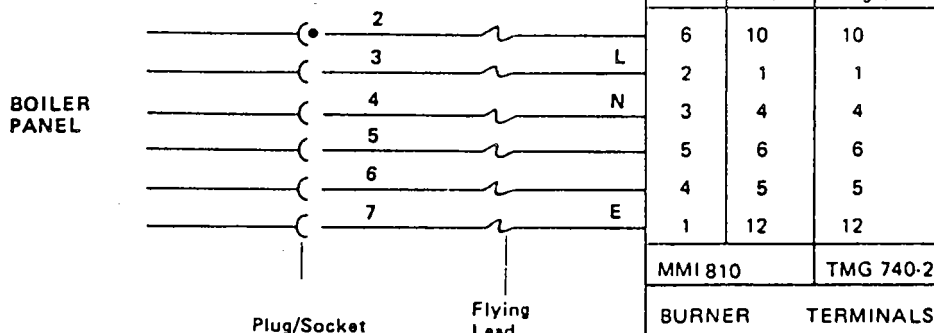

See Burner manual for internal burner wiring.

* High/Low Instrument to be connected between Terminals 7 & 8



POTTERTON AVON TWO

**COMMERCIAL
PRODUCTS
DIVISION**

NU-WAY OIL BURNER INFORMATION

To be read in conjunction with the Potterton 'Avon Two' boiler erection manual - Publication No. 558949 and the Nu-Way technical data sheet for the specific burner as supplied with the burner.

AVON TWO	SECTIONS	5	6	7	8	9	10	11	12	
OUTPUT	Btu x 10 /h kW	250 72	310 90	370 108	430 126	490 144	550 162	620 180	680 200	
NU-WAY BURNER MODEL		NL06	NL06	NL06	NL09	NL09	NL09	NL09	NL09	
TYPE OF CONTROL - standard:		ON/OFF	ON/OFF	ON/OFF	ON/OFF	ON/OFF	ON/OFF	ON/OFF	ON/OFF	
Optional features available using CL3 Burner	HI/LO fully closing air dampers	No No	No No	No No	No No	No No	Yes Yes	Yes Yes	Yes Yes	
FIRING RATE	L/h approx. Imp. g/h	8.49 1.87	10.61 2.33	12.74 2.80	14.86 3.27	16.98 3.74	19.11 4.20	21.23 4.67	23.59 5.19	
POWER REQUIREMENTS	Motor W 240v 1Ph 50 Hz Start current amps. Run current aps.	250 4.2 1.7	250 4.2 1.7	250 4.2 1.7	250 4.2 1.7	250 4.2 1.7	250 4.2 1.7	250 4.2 1.7	250 4.2 1.7	
CONTROL BOX	NL06 & NL09 Burner Alternative CL3 Burner	DANFOSS BH011 for ON/OFF with pre purge						Satronic TF701B HI/LO Satronic T10810 F.c.a.d.		
WIRING DIAGRAMS	NL06 & NL09 CL3	WDE-4600 WA4-6690 Harness WA4-7133						HI/LO WA4 6385/3 F.c.a.d. WA3 - 7145		

COMMISSIONING - OIL - NUWAY

Full details of the procedure for the initial commissioning of the burner are given in the Technical Data manual packed by the Manufacturers with each burner and these instructions should be carefully followed. The following summary may be found useful.

Bleed the oil supply line free of air up to the burner.

Lead the burner pump free of air by slackening off the plug in the pressure gauge port and if necessary running the burner motor BRIEFLY.

Check that the draught tube, diffuser and electrode settings are in accordance with the specification given. Check that the nozzle type size and spray angle are correct.

The following procedure is for on/off burners. For low flame start burners the air shutter should be set on low flame to give a smooth light up. For high/low burners the air shutter position should be set to give smoke free combustion on low flame (see manufacturer's instructions for further details).

Set the air shutter to the position indicated in the table. Switch the burner on electrically and flame should establish. Set pump pressure to that specified in table. Check combustion at boiler flue outlet. When the boiler is operating at its design temperature, the combustion figures should be as follows:- CO₂: 12%, Smoke No: 0-1, nett flue gas temperature less than 250°C, draught in excess of 1mm wg-ve. Adjust the air shutter/burner settings as necessary to give optimum combustion performance. Check that the thermostats switch the burner off by adjusting each below the temperature of the boiler/system water.

Check that the burner stops and the control box "locks-out" when the photoelectric cell is removed and light is excluded from its sensing head.

Check the pipework and connections for oil leaks.

Re-check combustion after approx. 30 minutes operation. If for any reason the burner cannot be commissioned satisfactorily, refer to the burner manufacturer's instructions and follow the fault finding procedure if necessary. Ensure that the boiler/burner unit is left fully commissioned and operating safely and correctly.

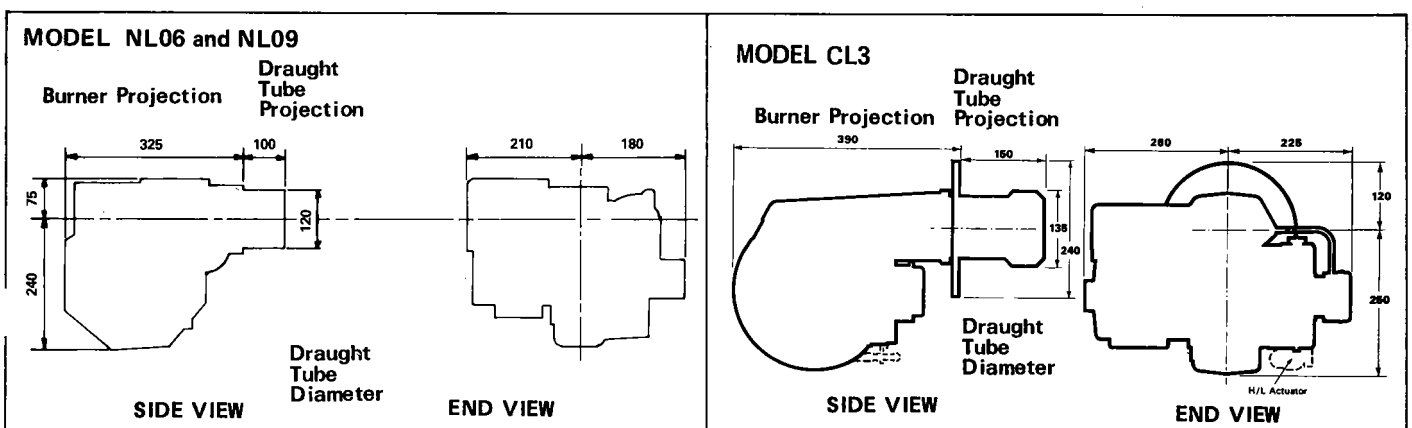

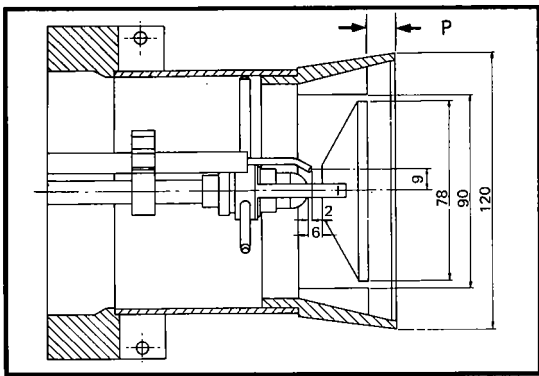

Adjustable head arrangement NL09 burner. Dimensions are in mm.

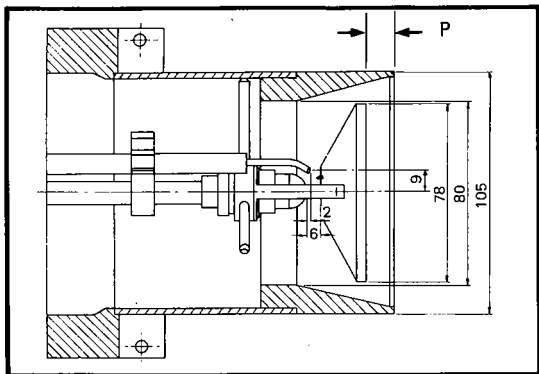

Adjustable head arrangement NL06 burner. Dimensions are in mm.

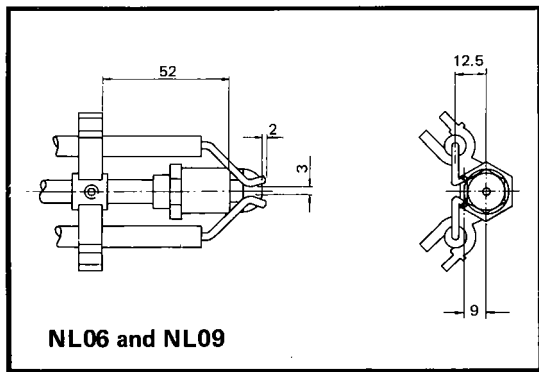

NL06 and NL09

Electrodes should be set to these dimensions to ensure trouble free ignition. Dimensions are in mm.

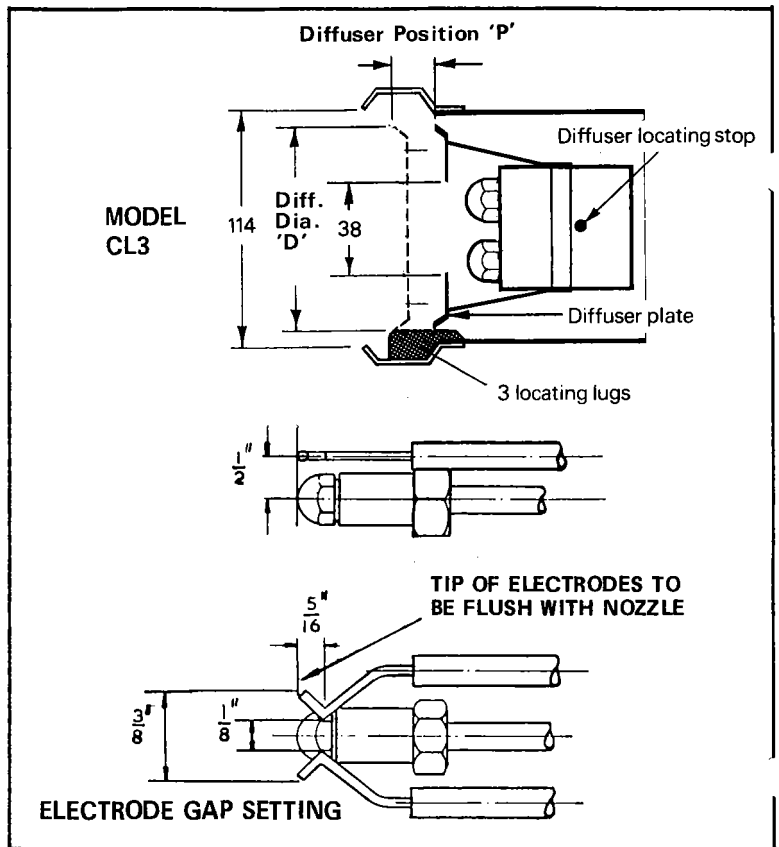

BURNER WIRING CONNECTIONS

BOILER PANEL	Wiring	NL06 NL09	CL3	CL3	Burner Terminals
		10	10	10	
	3 L	1	1	1	
	4 N	4	4	4	
	5	6	6	6	
	6	5	5	5	
	7 E	12	12	12	
		Danfoss BH011	Satronic TF701B	Satronic TT0810	
		ON/OFF	HI/LO*	F.c.a.d.	

* HI/LO Instrument to be connected between 7 & 8

BOILER SECTIONS	BURNER MODEL	OIL NOZZLE	PUMP PRESSURE		DIFFUSER DIAMETER 'D' mm	DIFFUSER POSITION 'P' mm	AIR DAMPER SETTING AT MAX FIRING RATE - approx.
			Bar	P.S.i.			
5	NL06	Monarch 1.75 60° A.R.	11.7	170	78	30	30% open
6	NL06	Danfoss 2.5 60° S	9.0	130	78	25	40% "
7	NL06	Monarch 3.0 60° P.L.P.	9.0	130	78	12	50% "
8	NL09	Monarch 3.5 45° P.L.P.	9.7	140	78	30	35% "
9	NL09	Monarch 4.0 45° P.L.P.	9.0	130	78	24	50% "
10	NL09	Monarch 4.0 45° P.L.P.	11.0	160	78	20	60% "
11	NL09	Monarch 4.0 45° P.L.P.	13.7	200	78	16	65% "
12	NL09	Monarch 4.5 45° P.L.P.	12.4	180	78	11	60% "
10	CL3	Monarch 2.75 + 1.25 60° A.R.	12.4	180	73*	20	50% open
11	CL3	Monarch 2.25 + 2.0 60° A.R.	12.4	180	89	43	30% "
12	CL3	Danfoss 3.0 + 1.5 60° S	12.4	180	89	42	60% "

*Restrictor Ring 92mm Bore

NU-WAY DUAL FUEL BURNER INFORMATION

AVON TWO - SECTIONS		5	6	7	8	9	10	11	12
OUTPUT	KW	-	-	-	-	144	162	180	200
	BTU/HR x 10 ³	-	-	-	-	490	550	620	680
NU-WAY BURNER TYPE DUAL FUEL	HIGH/LOW	-	-	-	-	NDF9	NDF9	NDF9	NDF9
	SPEC. NUMBER	-	-	-	-	S55-014S	S55-014S	S55-014S	S55-014S
FULLY CLOSING AIR DAMPER		← STANDARD →							
FIRING RATE	GAS m ³ /hr	-	-	-	-	17.32	19.48	21.65	24.06
	OIL l/hr	-	-	-	-	16.98	19.11	21.23	23.59
POWER REQUIREMENTS - MOTOR KW		-	-	-	-	0.25	0.25	0.25	0.25
240V 1PH 50HZ - START CURRENT	AMPS	-	-	-	-	7	7	7	7
	- RUN CURRENT	AMPS	-	-	-	1.7	1.7	1.7	1.7
CONTROL BOX		-	-	-	-	← TMG 740-2 →			
WIRING DIAGRAM		-	-	-	-	← WA1-7245 →			

NOTE

Commissioning should be carried out by qualified, experienced engineers. This facility is available from Potterton International Ltd, Commercial Service Office. See back page for details.

COMMISSIONING - DUAL FUEL - NUWAY

It is essential that the burner is never run without the oil supply connected. This oil supply should be a two pipe system or a single pipe with a spill back loop.

Full details of the procedure for the initial commissioning of the burner are given in the Technical Data manual packed by the manufacturer with each burner and these instructions should be carefully followed. The following summary may be found useful.

Ensure that both fuels are available at the plant isolating valves and that oil is Class D (35 second) and that the minimum inlet gas pressure to the burner when firing is 7 in.w.g.

With electrical and fuel supplies isolated check that the draught tube, oil nozzle, gas nozzle, diffuser and electrodes are to the specification shown and check that the settings are correct.

Commission on gas first by turning the oil ball valve on the oil line off and select gas on the fuel selector switch on the burner control panel and open the service cock which is fitted with a micro-switch.

Fit a monometer to the head and turn off the main gas cock and turn on the pilot gas cock. Turn on the burner, the fan will run, ignition spark will be established, a pilot flame will then be detected by the U.V. cell.

Open the main line gas cock and main flame will be established. Adjust the fuel air ratio control unit until 9.0% CO₂ and no CO is achieved. Adjust the air shutter setting to obtain the correct rate. Figures given overleaf may be used as a guide.

Return to low fire setting and if necessary trim the air fuel ratio by the parallel displacement adjuster and then adjust rate by adjusting air. The figures given overleaf may be used as a guide. Re-check high fire figures.

Set the pilot rate to no more than 25% of the stoichiometric gas rate for the proved air flow of high fire and commission the air pressure switch and gas valve closed position indicator switch.

Select oil on the fuel selector switch and open the oil ball valve on the burner. Close the service gas, cock which is fitted with a micro-switch.

Switch the burner on, allow to run to high fire and adjust the pump pressure to that given overleaf. Check combustion figures for 12.0% CO₂ and clear or a trace of smoke. If smoke is too high de-rate on pump pressure slightly or add air, however, adding air will mean that the gas will have to be recommissioned.

Select low fire and adjust the pump pressure by the adjuster on top of the oil pump. Check combustion figures and adjust as for high fire if necessary. Pump pressures are given overleaf.

Check that the thermostats operate correctly by adjusting each in turn to below the boiler water flow temperature and checking that the burner closes down.

Check that the control box goes to lockout if the U.V. cell is removed and covered up and that the burner will not light with the U.V. cell removed. If for any reason the burner cannot be commissioned satisfactorily refer to the burner manufacturers instructions and follow the fault finding procedure.

Allow the boiler/burner unit to run for approximately 30 minutes and recheck combustion figures on both fuels. Flue gas temperatures should be less than 250°C. Ensure that the boiler/burner unit is left fully commissioned and operating safely and correctly.

The secondary fuel should be selected periodically to ensure reliable and trouble free operation should it ever be required as the primary fuel.

NOTE: A manual gas cock and union is fitted as the service cock at the inlet to the gas train. This service cock is fitted with a micro-switch which is pre-wired through its contacts 1 and 3 to terminals 14 and 15 on the boiler terminal block.

NOTE: Systems for fully automatic changeover are available on request.

NDF9 BURNER

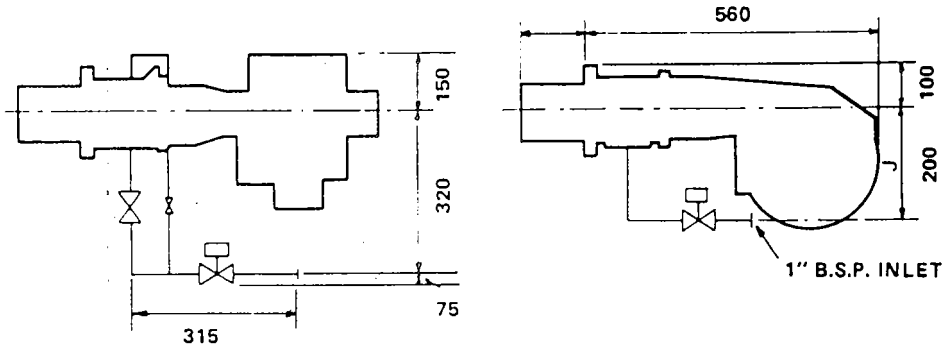

NDF9 BURNER HEAD

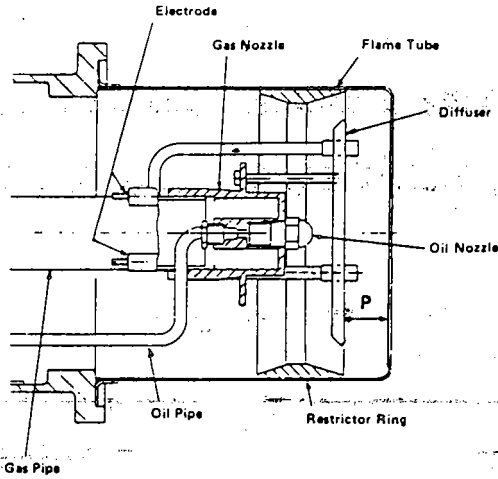

NDF9 BURNER ELECTRODES

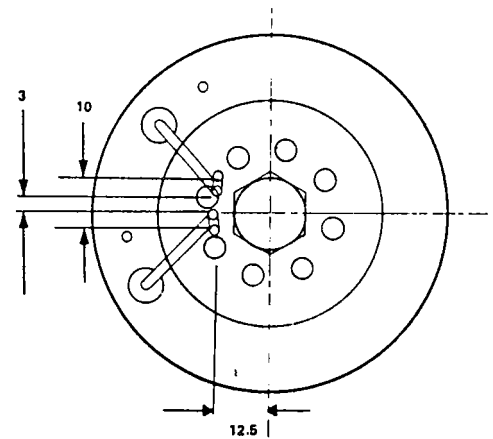

Tip of electrodes to be flush with the tip of the nozzle.

Boiler Ref.	Burner Model	Draught Tube		Diffuser		Burner head gas pressure (approx.)				Air damper setting % open	
		Diameter mm	Projection mm	Position Pmm	Diameter OD/IDmm	High		Low		High	Low
						In.wg	mm.Wg	In.wg	mm.Wg		
9	NDF9	133	150	37	110/33	3.3	83	1.3	33	70	15
10	NDF9	133	150	35	110/33	3.5	89	1.9	47	70	15
11	NDF9	133	150	29	110/33	4.1	105	2.6	66	80	20
12	NDF9	133	150	29	110/33	4.3	108	2.2	57	90	30

GAS NOZZLE : SIDE HOLES 8 OFF 4.0 mm END HOLES 8 OFF 4.0 mm

OIL NOZZLE AND PUMP PRESSURE CLASS D (35 SECOND) ONLY

9 SECTION	Monarch 2.5 45° PLP HI 320 PSI LO 140 PSI	11 SECTION	Monarch 3.5 45° PLP HI 260 PSI LO 130PSI
10 SECTION	Monarch 3.0 45° PLP HI 280 PSI LO 140 PSI	12 SECTION	Monarch 3.5 45° PLP HI 310 PSI LO 140PSI

* TURNDOWN APPROX. 1.4 to 1

BURNER WIRING CONNECTIONS

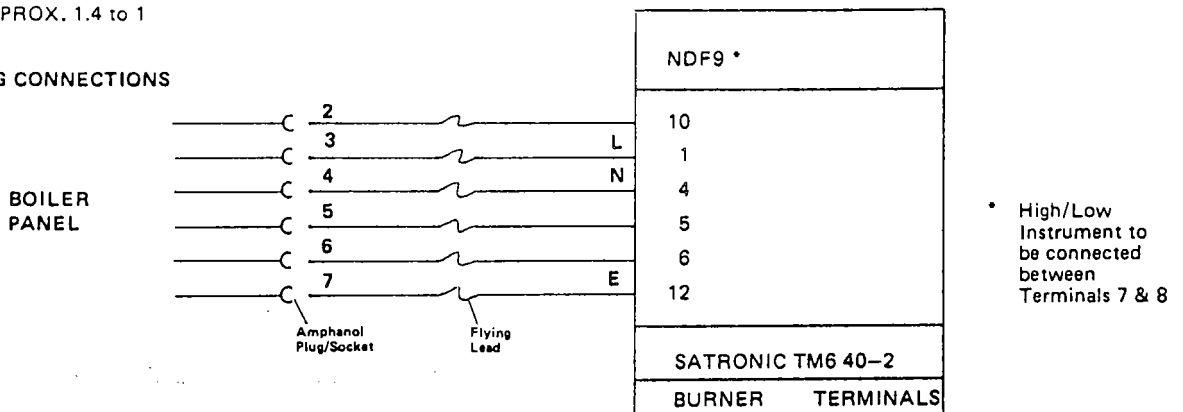

"All descriptions and illustrations contained in this leaflet have been carefully prepared but we reserve the right to make changes and improvements in our products which may affect the accuracy of the information contained in this leaflet"