

derwent prestige

INSTALLATION, OPERATION & MAINTENANCE MANUAL



**Meets the Requirements of
Part L 2**

MAY 2004

POTTERTON

COMMERCIAL

heating specialists

INDEX

Section 1

Fig 1 - General Data & Dimensions	1
Table 1 - Boiler Dimensions	1
Table 2 - Connections	1
Table 3 - Technical Data 5 to 12 Section	2
Table 4 - Technical Data 13 to 22 Section	3
Fig 2 - Steel Base Strip Details	5
- Clearances & Burner Info	5

Section 2

- General Information	6
- Standard Supply	6
- Controls	6
- Shipping & Packaging	6
- Installation - Boiler Siting & Base	7

Section 3

- Ventilation	8
- Flue Size Considerations	8
- Common Flue Systems	9
- Water Circulation systems	9
- Boiler Protection	9
- System Water Quality	9
- Sealed Systems	9

Section 4

- Boiler Erection - Risk Assessment	10
- Manual Handling	10
- Personal Protective Equipment	10
- Confined Spaces	10
- Electrical Safety	10
- Packing Details	10
- C.O.S.H.H	11
- Erection/Assembly Checklist	11
- Heat Exchanger Assembly	12
- Assembly of Boiler Block	12
Fig 3 - Section Assembly 1	12
Fig 4 - Stud Fixing	12
Fig 5 - Section assembly 2	12
Fig 6 - Section assembly 3	12
Fig 7 - Section Assembly 4	12
Fig 8 - Sealing Cord	12
Fig 9 - Section Assembly 5	12
- Fitting the Seals	13
Fig 10 - Section Assembly 6	13
Fig 11 - Section Assembly 7	13
Fig 12 - Section Assembly 8	13
Fig 13 - Section Assembly 9	13
Fig 14 - Section Assembly 10	13
Fig 15 - Section assembly 11	13
- Combustion chamber Base Plate	14
- Hydraulic Test of Boiler	14
Fig 16 - Ceramic Felt Assembly	14
- Installing Multiple Unassembled Boilers	14
Fig 17 - Minimum Clearance Multiple Boilers	14
- Fitting of Burner Assembly	15
- Boiler Maintenance	16
- Fitting Flue Hood & Burners	17
- Combustion Chamber Front Plate	17
- Handing	17
Fig 18 - Flue Hood Assembly	17

Fig 19 - Flue Hood Assembly	17
- Assembly of Casing 5 to 8 Section	18
Fig 20 - General Arrangement of Casing (5 to 8 Section)	18
Fig 21 - General Arrangement of Casing (5 to 8 Section)	19
- Assembly of Casing 9 to 22 Section	20
Fig 22 - General Arrangement of Casing (9 to 22 Section)	20
Fig 23 - General Arrangement of Casing (9 to 22 Section)	21
Fig 24 - General Arrangement of Thermostat Pocket	22
- Connecting the Water System	22
- Connecting the Electrical Supply	22
- Connecting the Flue	22
- Boiler Disassembly	22
- Connecting the Pilot Line	23
Fig 25 - General Arrangement of Pilot Burner	23
- Connecting the Gas Supply	24
Fig 26 - Control Panel Configuration	24
- Boiler Controls	24
- Commissioning Check List	25
- Contravention of Regulations	25
- Commissioning	25
- Emergency Instructions	26
- Pre-Lighting	26
- Commissioning Live Run	27
- Setting the Gas valve 5 to 11 Section	27
Fig 27 - Dungs MB – ZRDLE	28
- Setting the Gas Valve 12 to 22 Section	28
Fig 28 - Gas Train 12 to 22 Section	28
- Ionisation Current Check	28
- Flue Spillage Test	28
- Ventilation Checks	29
- Operation of Ancillary Controls	29
Fig 29 - Controls & High/Low Thermostats	29
- Water Flow Switch	29
- Boiler Maintenance	29
- Boiler Cleaning	30
- Fault Finding	30
- Burner Lockout	31
- Check List	32
- Component Replacement	33

Section 5

Fig 30 - Gas Train Configuration	34
Fig 31 - Pump Overrun	35
Fig 32A - Boiler Wiring Diagram	36
- Legend for Wiring Diagram	36
Fig 32B - Boiler Wiring Diagram	37

Section 6

Part Nos.	38-52
Fig 33 - Boiler Body	38
Fig 34 - Burner Assembly	41
Fig 35 - Casing Assembly	44
Fig 36 - Flue Box	46
Fig 37 - Control Panel	48
Fig 38 - Gas Valve	50

DERWENT PRESTIGE

Fig.1 - General Data & Dimensions (mm) (NOT TO SCALE)

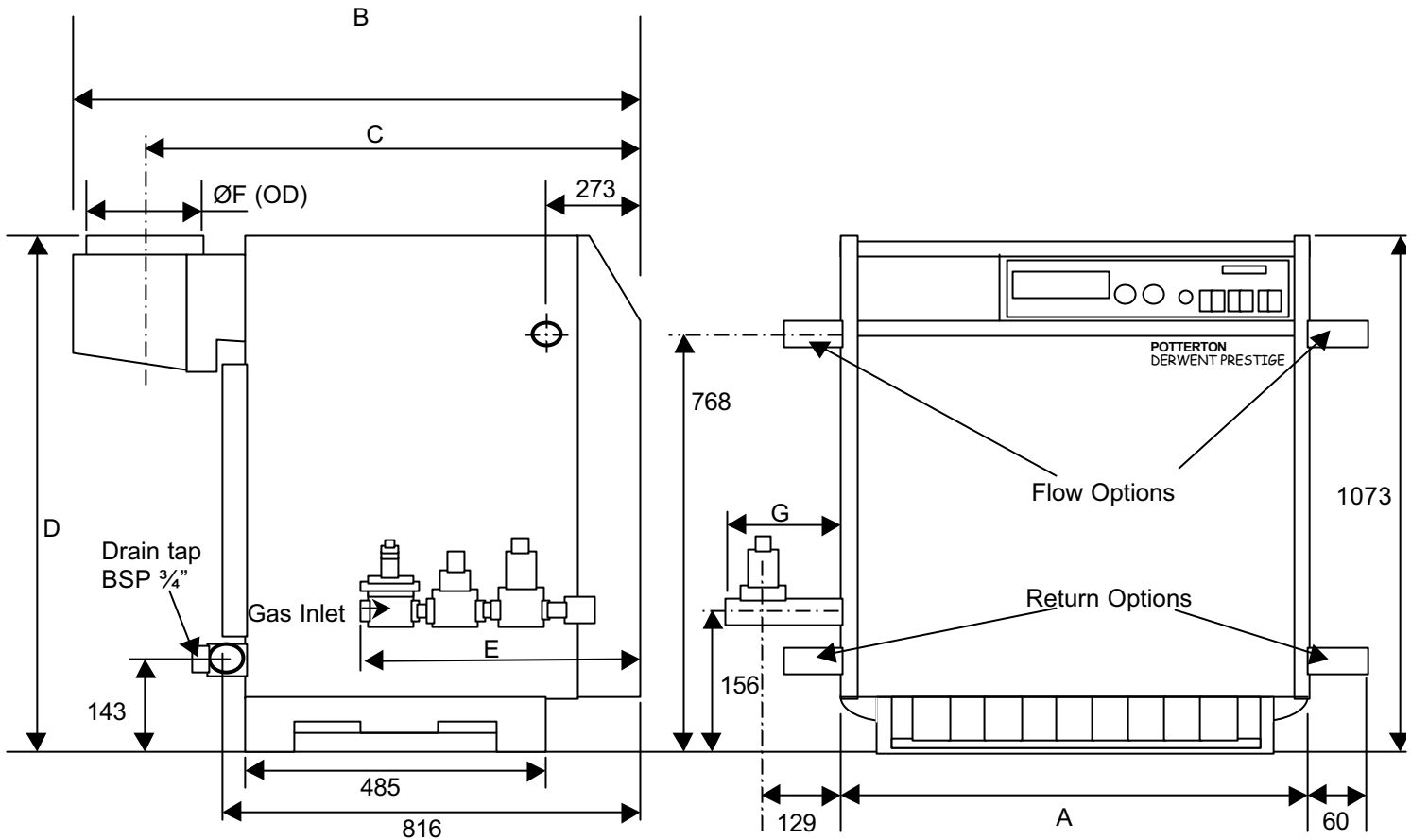

Table 1 - Boiler Dimensions

Sections	5	6	7	8	9	10	11	12	13	14	15	16	17	18	20	22
Output kW	66	83	99	116	133	149	166	182	199	215	232	248	265	282	315	348
A mm	707				788	869	950	1031	1112	1193	1274	1355	1436	1517	1679	1841
B mm	1075	1095		1145			1195			1245		1295				
C mm	960	970		995			1020			1045		1070				
D mm	1005				1015				1175							
E mm	437	537			836**			910**								
ØF mm	182	202		252			302			352		402				
G mm	210				227				254							

**From the 12 section the gas connection & return connection cannot be made on the same side.

Table 2 - Connections

	5	6	7	8	9	10	11	12	13	14	15	16	17	18	20	22
Water	1 ½" BSP							2" BSP							2 ½" Flange (PN6 DN65)*	
Drain	¾" BSP – drain cock supplied															
Gas	¾" BSP	1" BSP					1 ½" BSP					2" BSP				

* 20 & 22 Section flow and return are screwed flanged connections - mating flanges supplied

Note: only one flow and one return connection can be used.

Refer to page 18 for details on handing options for boiler flow, return and gas connections.

TABLE 3 - Technical Data (5 to 12 section)

	Number of Sections	5	6	7	8	9	10	11	12	
	CE Certification Number	0063AS3312								
	Output kW	66	83	99	116	133	149	166	182	
1	Fuel Consumption (G20) m ³ /hr	7.5	9.3	11.2	13.1	14.9	16.8	18.6	20.5	
	Input (Nett) kW	72	90	108	126	144	162	180	198	
	Input (Gross) kW	80	100	120	140	160	180	200	220	
	Nominal Gas Inlet Pressure mbar	20								
	Burner Manifold Pressure mbar	High Fire 16.5 / Low Fire 10.6								
	Burner Injector Size mm	3.2								
	Maximum Design Pressure Bar	5								
2	Minimum Operating Pressure Bar	0.5 (0.1 bar Available on request)								
3	Nominal Flue Connection Size Ømm	180	200	250				300		
	Internal Diameter of Diverter Socket to BS 835 Ømm	213	240	290				344		
4	Flue Gas Volume m ³ /hr	130	162	195	228	259	292	323	356	
	Flue Draught Requirements	1 - 4 mm ALL SIZES								
5	High Level Natural Ventilation to BS 6644 cm ²	315	360	405	450	495	540	585	630	
5	Low Level Natural Ventilation to BS 6644 cm ²	630	720	810	900	990	1080	1170	1260	
6	Mechanical Inlet to BS 6644 m ³ /sec	0.088	0.110	0.132	0.154	0.176	0.198	0.22	0.242	
7	Water Connection Size BSP	1 1/2"							2"	
8	Water Flow at 11°C Δt lit/sec	1.4	1.8	2.1	2.5	2.8	3.2	3.5	3.9	
	Min Water Flow at 25°C Δt lit/sec	0.62	0.78	0.94	1.10	1.25	1.41	1.56	1.72	
8	Hydraulic Resistance at 11°C Δt kPa	4.1	5.72	7.66	9.88	12.81	15.78	18.55	22.43	
9	Cold Feed Size to BS 6644 Minimum Bore mm	25						32		
9	Open Vent Size to BS 6644 Minimum Bore mm	32						38		
	Safety Valve Size to BS 6644 Nominal Size mm	19								
2	Maximum Flow Temperature °C	90								
10	Minimum Return Temperature °C	°C-----60°C (40°C with direct compensation)								
11	Dry Weight kg	285	330	375	415	470	515	560	610	
	Water Content kg	29.9	34.6	39.2	43.08	48.5	53.1	57.7	62.4	
	Power Requirements	230V 50Hz 1Ph - Isolator and 6.3A fuse required								

For metric to imperial conversions refer to conversion chart inside back cover

DERWENT PRESTIGE

TABLE 4 - Technical Data (13 to 22 section)

	Number of Sections		13	14	15	16	17	18	20	22	
	CE Certification Number		0063AS3312								
	Output	kW	199	215	232	248	265	281	315	348	
1	Fuel Consumption (G20)	m ³ /hr	22.4	23.8	26.1	28	29.8	31.7	35.4	39.2	
	Input (Nett)	kW	216	234	252	270	288	306	342	378	
	Input (Gross)		240	255	280	300	320	340	380	420	
	Nominal Gas Inlet Pressure	mbar	20								
	Burner Manifold Pressure	mbar	High Fire 16.5 / Low Fire 10.6								
	Burner Injector Size	mm	3.2								
	Maximum Design Pressure	Bar	5								
2	Minimum Operating Pressure	Bar	0.5 (0.1 bar Available on request)								
3	Nominal Flue Connection Size	Ømm	300				350		400		
	Internal Diameter of Diverter Socket to BS 835	Ømm	344				390		440		
4	Flue Gas Volume	m ³ /hr	389	414	454	487	518	551	615	681	
	Flue Draught Requirements		1 - 4 mm ALL SIZES								
5	High Level Natural Ventilation to BS 6644	cm ²	675	709	765	810	855	900	990	1080	
5	Low Level Natural Ventilation to BS 6644	cm ²	1350	1418	1530	1620	1710	1800	1980	2160	
6	Mechanical Inlet to BS 6644	m ³ /sec	0.264	0.281	0.308	0.330	0.352	0.374	0.418	0.462	
7	Water Connection Size	BSP	2"						Flanged 2 ½"		
8	Water Flow at 11°C Δt	lit/sec	4.2	4.6	4.9	5.3	5.6	5.9	6.4	7.1	
	Min Water Flow at 25°C Δt	lit/sec	1.85	2	2.15	2.3	2.46	2.61	2.8	3.1	
8	Hydraulic Resistance at 11°C Δt	kPa	25.83	29.22	33.11	36.93	41.32	45.6	39.09	48.15	
9	Cold Feed Size to BS 6644 Minimum Bore	mm	32							38	
9	Open Vent Size to BS 6644 Minimum Bore	mm	38							50	
	Safety Valve Size to BS 6644 Nominal Size	mm	19					25			
2	Maximum Flow Temperature	°C	90								
10	Minimum Return Temperature	°C	°C-----60°C (40°C with direct compensation)								
11	Dry Weight	kg	656	703	750	798	845	895	990	1090	
	Water Content	kg	67	71.6	76.3	80.9	85.5	90.2	100.5	110.5	
	Power Requirements		230V 50Hz 1Ph - Isolator and 6.3A fuse required								

See Page 4 for explanatory notes

Conversion table on inside of back cover

1. FUEL CONSUMPTION

Gas fuel consumption is based on natural gas with a gross calorific value of 38.6 MJ/m³. The gas rate should be corrected for the meter supply pressure particularly on high pressure supplies to prevent overfiring.

2. MINIMUM OPERATING PRESSURE

This is the minimum operating pressure of the boiler with pumps operating (NOT static pressure). The requirements of the Health & Safety Executive guidance note PM5 regarding maximum operating temperatures should be observed.

3. BOILER FLUE CONNECTION

A spun aluminium flue adaptor is included for convenience that is designed to accommodate BS835 twin wall flue pipe. It is not obligatory to use this adaptor but always ensure that the internal diameter of the flue used is no smaller than the connection on the flue collector hood (see table 3 & 4 for nominal flue connection size. For transport the adaptor is tie wrapped to the flue hood.

4. FLUE GAS VOLUME

Flue gas volumes are given at STP (standard temperature and pressure [15°C and 1013.25 mbar]). Typical flue gas temperatures for flue sizing are 140°C at 6.5% CO₂ with 1mm draught at the boiler flue connection.

5. NATURAL VENTILATION

The sizes indicated are free grille areas and are based on a single boiler installation.

6. MECHANICAL VENTILATION

The volume given is for a single boiler installation.

7. WATER CONNECTION SIZES

The boiler water connections are screwed BSP connections up to 18 section and the 20 and 22 section sizes are flanged 2¹/₂" with screwed counter flanges provided.

NOTE: Only one flow connection and one return connection can be used on each boiler.

8. WATER FLOW RATES

Water flow rates are given for boiler flow and return temperature differentials of 11°C.

9. COLD FEED/OPEN VENT/SAFETY VALVE SIZES

Sizes indicated are minimum sizes for single boiler installations.

10. MINIMUM RETURN TEMPERATURE

If system return temperatures below 55° are required then contact the Potterton Commercial Technical Department.

11. WEIGHT

The dry weight is inclusive of the gas train. Each section measures approximately 800mm (high) x 500mm (wide) x 80mm (deep) and weighs approximately 40 kg.

ANY PERSON OR PERSONS MOVING OR LIFTING SHOULD BE TRAINED IN MANUAL HANDLING TECHNIQUES AND IF NECESSARY USE SUITABLE LIFTING EQUIPMENT TO REDUCE THE RISK OF INJURY TO THEMSELVES OR OTHER PEOPLE.

DERWENT PRESTIGE

Fig.2 - Steel Base Strip Details

The Derwent Prestige is designed to be installed directly on the boiler room floor, provided that it is adequate. (See page 6 – Boiler Siting & Base).

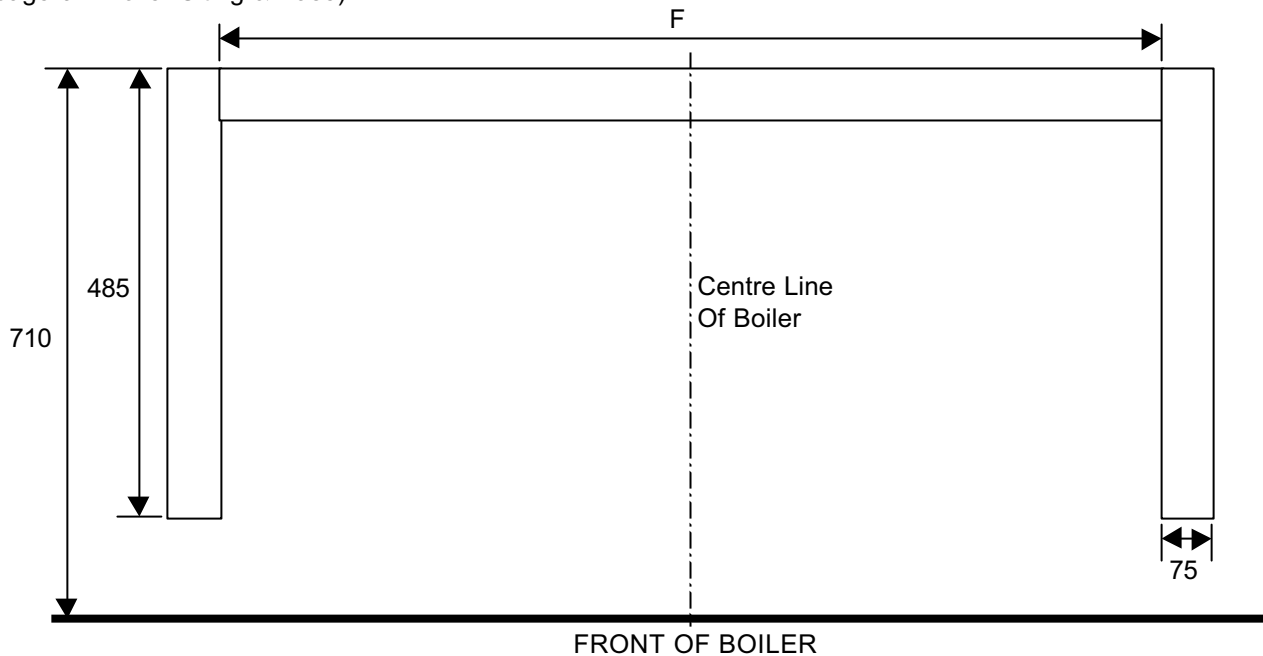

Sections	5	6	7	8	9	10	11	12	13	14	15	16	17	18	20	22
F mm	243	324	405	486	567	648	729	810	891	972	1053	1134	1215	1296	1458	1620

The boiler feet **must never** be fixed in position (this is to allow for expansion).

CLEARANCES - The minimum boiler room clearances for access, erection and maintenance are as follows: -

- REAR - 100mm from rear of flue hood.
- SIDES - 500mm on gas train side, 200mm on the other
- FRONT- 700mm to allow for burner removal.
- TOP - 1000mm to allow for cleaning.

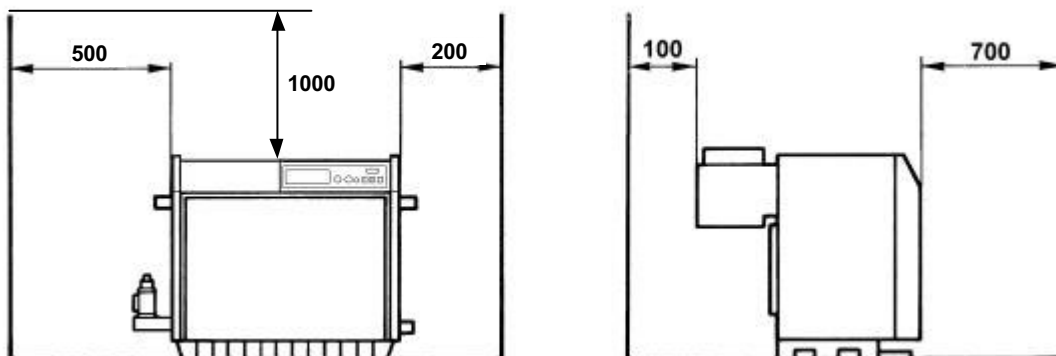

Flammable products should **never** be stored in the space around the boiler. Any walls that are sensitive to heat should be protected by an appropriate insulation.

BURNER INFORMATION

The Derwent Prestige boiler is fitted with low NOx Furigas atmospheric burners.
 NOx emission 70-120 mg/kWh, Class 3 certified to EN297: 1994 / A3: 1996.

GENERAL

This boiler is **NOT SUITABLE** for installation in a normally occupied area (i.e. kitchen).

A **LIFETIME GUARANTEE** is available on this boiler please refer to our standard terms and conditions for details.

The Potterton Derwent Prestige cast iron sectional boiler is available in sixteen sizes from 66kW (5-section model) to 348kW (22-section model). Tables 3 (page 2) and 4 (page 3) give kW outputs and technical data for each model.

	Nat Gas LPG	
	100 %	30%
Gross	82.9%	82.9%

They are approved for use on open vented systems (minimum head 5mm), however, they are suitable for use on sealed systems with a minimum operating pressure of 0.5 bar (0.1 bar Available on request) and a maximum operating pressure of 5 bar (73.5 p.s.i.). Refer to relevant British Standards and Codes of Practice regarding the installation of Derwent Prestige boilers on sealed systems.

For sites with restricted access the boiler block, with the burner and drain cock removed, will pass through a 660mm doorway.

If necessary the boiler block can be easily stripped down into individual sections. Each section weighs approximately 40kg and the principle dimensions are 800 × 500 × 80mm.

All assembled boilers are delivered with the gas train made to the left-hand side. For conversion requirements see page 15. The Electrical connection to the gas train assembly must be connected on site by an in line plug and socket which is connected to the control panel. (as delivered).

On the 20 and 22 section boilers the flow and return connections **cannot** be made on the same side of the boiler – they **must be** diagonally opposite.

On the 12 to 22 section boilers the return connection and gas train **CANNOT** be on the same side of the boiler.

The boiler sections are cast iron with pips to aid heat transfer and they are joined by EPDM flat sealing washers to flow and return manifolds.

The boiler sections are insulated by 50mm glass fibre insulation. The case is finished in a powder coat paint as follows:

Red – RAL 3001

Grey – (Non Standard but closest match RAL 7024)

Assembled Boiler**STANDARD SUPPLY**

- Cast iron sections
- Flue hood
- Insulated, painted steel case
- Eco-control panel
- Cleaning brush
- Drain Cock

CONTROLS

The fully automatic control system, which incorporates full safety features, includes control and high limit thermostats, thermometer and burner on/off switch. All models have automatic ignition with a sequential control box and an ionisation flame failure device fitted to an interrupted low energy pilot burner. Including two volt-free remote status contacts

OPTIONAL EXTRAS

- Additional volt-free contacts
- Hours run meters
- Sequence controls & zone controls

SHIPPING – PACKAGING

The 5 to 16 section boilers are delivered fully assembled with boiler, burner and flue hood on a pallet plus separate cartons for gas train, control panel and casing pack.

The 17 to 22 section boilers are delivered unassembled with sections, flue hood, burner, gas train, and casing pack, on one pallet.

It is recommended that the Potterton Commercial Division's trained engineers should carry out erection and commissioning, as this will make valid the LIFETIME GUARANTEE. See back page of the manual for the addresses of the Service Offices

DERWENT PRESTIGE

INSTALLATION

The boiler should be installed in a CLEAN boiler house free of dust and corrosive vapours. During insulation of system pipework and heavy building construction work around the boiler, the boiler must be switched off to avoid damage.

Before starting work a risk assessment should be carried out in the boiler house and its access to determine and ensure a safe installation and working environment.

Any person installing or working on the boiler must be qualified & competent, and in the case of gas fired boilers attention is drawn to the mandatory requirement of C.O.R.G.I Registration and qualified to A.C.O.P's element 16. Also they must be electrically competent and adhere to the IEE Regulations.

Boiler log book supplied.

Manual Handling – Any person or persons moving or lifting the boiler or any part of it, should be trained in manual handling techniques and if necessary use suitable lifting equipment to reduce the risk of injury to themselves or other people.

The installation should comply with the relevant British Standard Specifications, Codes of Practice and current Building Regulations, together with any special regional requirements of the local authorities, gas undertaking and insurance company. All electrical wiring must comply with I.E.E. Regulations for the Electrical Equipment of Buildings.

The installation of the boiler must be in accordance with the relevant requirements of: -

Health & Safety at Work Act 1974.

BS 5440-1: 2000: Specification for Installation of Flues.

Building Regulations 1991.

Electricity at Work Regulations 1989.

Management of Health & Safety at Work Regulations 1992.

Manual Handling Regulations 1992.

Model Water By-laws 1986.

BS 5440-2: 2000: Specification for Installation of Ventilation for Gas Appliances.

BS 6644: 1991 – Installation of Gas Fired Hot Water Boilers for Inputs between 60kW and 2MW.

BS 7074: 1989: Part 2 – Application Selection & Installation of Expansion Vessels & Ancillary Equipment for Sealed Water Systems.

BS 6880: 1988 – Codes of Practice for Low Temperature Hot Water Systems.

BS 779: 1989 Cast Iron Boilers for Central Heating & Indirect Hot Water Supply (Rated Output 44kW and above).

CP342:2 – Centralised Hot Water Supply

Gas Safety (Installation & Use) Regulations 1994

IM/11 Flues for Commercial and Industrial Gas Fired Boilers and Air Heaters.

IGE/UP/1 Soundness testing & Purging Procedure for Non-Domestic Installations.

IGE/UP/2 Gas Installation Pipework, boosters Compressors in Industrial & Commercial Premises.

BS 7671: 1992 Requirements for Electrical Installation, IEE Wiring Regulations 16th Edition.

Manufacturers notes must not be taken in any way as overriding statutory obligations.

BOILER SITING & BASE

The boiler should be sited in accordance with BS 6644: 1991 with respect to protecting the boiler from damage, air for combustion and ventilation, discharge of products of combustion, clearances for service and access, temperatures, noise levels, the disposal of boiler house water and the effects of flooding of the boiler house or seepage from a roof top boiler house. See section 1 for required boiler clearances for service and cleaning.

A level non-combustible floor capable of supporting the weight of the boiler filled with water, see Table 3 (page 2) and 4 (page 3) together with any additional weight bearing down on the base from connections, etc, must be provided. This should be of an adequate height above the floor so as to be raised in the case of flooding, but low enough to allow ease of erection. Typically a 50mm concrete plinth with an area equal to that of the plan of the boiler is adequate in most cases

Heating systems must be installed so that water cannot be returned from the heating system to the drinking water system to which it is connected to prevent the drinking water being contaminated by the heating water or chemicals used in the heating water.

Steel strips should be provided (not supplied by Potterton Commercial) to support the left and right hand section feet and the back feet of the intermediate sections, see Fig 2, page 5 for details. These strips should typically be 75mm wide and 5mm thick.

L.P.G boilers **MUST NOT** be installed in basements/below ground or in a well.

For further advice on installations, refer to the relevant Potterton Technical Bulletins.

VENTILATION

Safe, efficient and trouble free operation of conventionally flued boilers is vitally dependent on the provision of an adequate supply of fresh air to the room in which the appliance is installed. Account must also be taken of any other fuel burning appliance existing or to be fitted when designing the ventilation and combustion air systems.

IMPORTANT: The use of an extractor fan in the same room as the boiler (or in an adjacent room in communication) can, in certain conditions, adversely affect the safe operation of the boiler and therefore must be avoided.

Further Guidance on Ventilation for Gas Appliances is provided by B.S 6644:1991.

FLUE

To ensure safe and satisfactory operation the chimney system, which may be individual or common in the case of modular boiler installations, shall be capable of the complete evacuation of combustion products at all times. The effective height of the chimney terminal(s) above the boiler(s) flue outlet(s) shall ensure sufficient buoyancy to overcome the resistance of the bends, tees and runs of the flue pipe involved and shall terminate in a down draught free zone. The number of bends used should be kept to a minimum and flue runs should not be less than 45° to a horizontal should be avoided in order to comply with the recommendations made in BS 6644:1991, British Gas Publication IM/11 "Flues for Commercial and Industrial Gas fired Boilers and Air Heaters". The third edition of the 1956 Clean Air Act Memorandum and the Building Regulations should be strictly observed and approval obtained where applicable.

The chimney design should avoid the formation of condensate, which may be achieved by insulating the flue.

The flue system must be designed to work specifically to remove the products of combustion.

IMPORTANT: 90° square bends must not be used on the flue system, 2 × 45° bends or easy sweep pattern should be used. A minimum of 600mm straight vertical flue should be taken off the boiler flue outlet prior to any fittings.

FLUE SIZE CONSIDERATIONS

Nominal flue connection sizes are given in Table 3 and 4, these sizes refer to the boiler flue connection socket, detailed dimensions of the flue adaptor to BS 835 are given in table 3 and table 4.

The actual size of the flue system will depend on individual site applications. Detailed below are general considerations on sizing flue systems. These notes are for guidance only and Potterton Commercial Division cannot accept responsibility for any flue system designs.

Horizontal Flue Runs

Horizontal flue runs only add to the flue resistance without creating any buoyancy and must be avoided. Sloping flue runs should not be less than 45° to the horizontal. Flue resistance should be kept to a minimum but flues should not be oversized as this may lead to cold start spillage.

Where horizontal flue runs are unavoidable owing to building constraints advice should be sought from a flue specialist.

Common Flue Systems

Where multiple boilers are installed on a common flue system then the flue system should be designed to ensure the correct operation of the flue on varying load conditions. In particular that the appliance flue draught is within the operating parameter under full load and partial load conditions. For safe and reliable operation of the boiler plant it is recommended that the variance in flue draught available at each appliance under full and part load operation is designed to a minimum.

(It is recommended that the services of a specialist flue system manufacturer are sought for the design of common flue systems).

For initial flue design a flue size equivalent to the total free area of the boiler flue outlet should be used as a minimum.

For further information regarding ventilation & flueing see Potterton Technical Bulletin No. 4, current issue or see relevant British Standard Publication BS6644:1991.

THE ABOVE RECOMMENDATIONS ARE FOR GENERAL GUIDANCE ONLY. POTTERTON COMMERCIAL DIVISION CANNOT ACCEPT RESPONSIBILITY FOR FLUE SYSTEM DESIGNS BASED ON THE ABOVE RECOMMENDATIONS.

DERWENT PRESTIGE

WATER CIRCULATION SYSTEMS

The water circulation systems should be indirect and installed in accordance with the relevant parts of British Standards Codes of Practice CP342 and BS 6644: 1991.

The maximum and minimum design temperature differential across the boiler should be 20°C and 10°C and the boiler should be prevented from operating with flow rates giving a temperature difference across the boiler greater than 25°C based on the full boiler output. Boilers operating under constant flow conditions can be more accurately controlled and are not subject to excessive temperature stresses.

The boilers **MUST NOT** be fired under any circumstances with less than the minimum water flow.

On systems with variable flow rates due to flow reducing devices, ie. TRVs, zone valves, etc, or where the minimum heat demand, ie. summer domestic hot water load, does not achieve the minimum boiler flow rate then consideration shall be given to incorporating a primary loop system. For further information see Potterton Publication Technical Bulletin No.1 Issue 2. It is recommended that the system is designed to give a constant flow rate. For further information on water circulation systems see Potterton publication Technical Bulletin No.1, and Technical Bulletin No.3 current issue.

BOILER PROTECTION

The provision of pump overrun by a time delay relay or a thermostat situated in the flow pipe close to the boiler is essential to remove residual heat from the boiler, see Fig. 32, page 35.

The boiler and system should be protected by suitable frost thermostats.

Never fill a hot boiler with cold water. Sudden cooling may cause the cast iron to fracture under the stress.

Unions and isolating valves should be fitted to the flow and return manifolds so that the boiler can be isolated from the system if the need arises.

SYSTEM WATER QUALITY

High efficiency boiler systems require the water quality of the system water to be controlled by the use of inhibitors to maintain a neutral Ph and inhibit corrosion. Additionally the water system should be free of leaks to prevent raw water make up which will dilute any inhibitors, promote corrosion and form lime scale.

Existing Systems

On existing systems where boilers are being replaced due to failure then the cause should be investigated before installing new boilers. This can normally be achieved by cutting open a failed boiler section and examination for system debris or contamination.

Lime scale is a positive indicator of continuous system water make up due to water loss. Evidence of magnetite (black sludge) in the system and the formation of gas in radiators causing air locking is a positive indicator of corrosion.

Where an old system shows evidence of contamination then system cleaning should be carried out before installation of new boilers. The heating system should be chemically flushed to remove any lime scale or corrosion and a corrosion and lime scale inhibitor added. Lime scale descalers if incorrectly used could cause any remaining system debris to continue to breakdown and contaminate the new boiler causing boiler failure.

Advice on system cleaning and suitable products should be sought from specialist suppliers of system cleaners such as Fernox or Sentinel.

It is important to note that corrosion inhibitor can only be used in an attempt to prevent corrosion from occurring, where a system has an existing corrosion problem, inhibitors will be ineffective and the system requires cleaning.

On existing systems where comprehensive descaling and desludging cannot be carried out then consideration should be given to separating the new boiler system from the existing system pipe work by the use of plate heat exchangers.

New Systems

New pipe work systems should be thoroughly flushed with a suitable cleaning agent to remove debris and flux residues before filling. The system water should be dosed with a suitable corrosion and lime scale inhibitor.

System Water Monitoring

The system water should be monitored as part of a maintenance programme to ensure the following. Raw water make up is not occurring. Corrosion and lime scale Inhibitors are still active Water Ph is below Ph 8.5 other wise on systems with aluminium content, component failures may occur.

SEALED SYSTEMS

General

Potterton Commercial boilers are suitable for use on sealed systems designed in accordance with BS 6644: 1991 and BS 6880 Part 2. In addition, reference should be made to the Health & Safety Executive guidance note PM5 "Automatically Controlled Steam & Hot Water Boilers".

Noise Level

Derwent Prestige atmospheric boilers are regarded as being 'commercially quiet', ie < NR63 under typical operating conditions

BOILER ERECTION

A Lifetime Guarantee is available on this boiler when the Potterton Commercial Service Department carries out Erection & Commissioning and the system meets with our recommendations. Please refer to our Standard Terms and Conditions for further details.

Risk Assessment

Before starting work a risk assessment should be carried out in the boiler house and its access to determine and ensure a safe installation and working environment.

Regardless of the type of activity being assessed, the principles of risk assessments are the same. The basic steps are: -

- Classify Activity
- Identify Hazards
- Identify Existing Control Measures
- Determine Risk
- Assess Acceptability of Risk
- Prepare a Control Plan
- Implement Plan
- Review Plan
- Record Results

Manual Handling

Any person or persons moving or lifting the boiler or any part of the boiler, should be trained in Manual Handling Techniques and if necessary use suitable lifting equipment to reduce the risk of injury to themselves and other people.

Personal Protective Equipment

When undertaken any work you must comply with the Personal Protective Equipment Regulations 1992.

Confined Spaces

A "confined space" as defined in the Health and Safety Confined Spaces Regulations 1997 ' means any place, including any chamber, tank, vat, silo, pit, trench, pipe, sewer, flue, well or other similar space in which, by virtue of its enclosed nature, there arises a reasonably foreseeable specified risk.

Precautions should be taken in all areas where, by virtue of its even partially enclosed nature, pose a reasonably foreseeable specified risk.

Electrical Safety

Working on appliances can be broken down to two main systems of work.

- 1.) Safe systems of work are adapted for all boiler maintenance & repair work undertaken on site.
- 2.) The work undertaken does not affect the electrical safety of the appliance. In particular the earth connected to the buildings fixed electrical installation.

In the case of (1) above electrical work should only be undertaken once the boiler has been isolated from the electricity supply and confirmed electrically dead. If this is impractical then suitable precautions must be undertaken to prevent injury.

In the case of (2) above checks are specified to identify any abnormality in the electricity supply to the boiler as well as to confirm that the boiler electrical connections are reinstated correctly where it is necessary to disconnect or reconnect any internal wiring within the boiler.

If it is necessary to disconnect and reconnect the appliance from the site electrical installation other than means of a plug and socket then additional checks shall be undertaken by an approved engineer to check the earth loop impedance in accordance with IEE regulations.

Always carry out preliminary electrical safety checks.

All appliances and central heating systems must be provided with their own means of isolation for safety purposes especially during installation and maintenance.

Preparation

Before the installation of the boiler a check must be made to ensure that suitable facilities are available for off-loading the boiler (the 5 to 16 section boilers come with assembled heat exchanger) and conveying it to the boiler room. Each waterway section weighs approximately 40 Kg and measures 800mm x 500mm x 80mm. Ensuring all Manual Handling Techniques are followed.

Particular attention must be paid to ensuring cleanliness of the boiler room and waterway sections, dust or moisture may result in imperfect adhesion of the sealants which are applied during the erection of the waterways. All tapped holes should be degreased before making connections.

DERWENT PRESTIGE

C.O.S.H.H

During the erection procedure there are a number of items which are subject to the Control Of Substances Hazardous to Health (C.O.S.H.H) Regulations, and may require specialist Personal Protective Equipment (P.P.E) beyond what is normally required. Listed below are the items subject to the C.O.S.H.H Regulations and the recommended precautions that should be taken. For a full breakdown of any substances listed below, please contact the Commercial Technical Department.

- 1) **Refractory Ceramic Fibre Insulation** –
Wear gloves, overalls and safety glasses, in the case of an irritation rinse the affected area with water and wash gently, in the case of eye contact, flush abundantly with water, if irritation persists seek medical advice.
- 2) **High Temperature Glass Fibre Insulation** –
Wear gloves, overalls and safety glasses, in the case of an irritation rinse the affected area with water and wash gently, in the case of eye contact, flush abundantly with water, if irritation persists seek medical advice.
- 3) **Adhesive** – Wear gloves, overalls, in the case of an irritation rinse the affected area with water and wash gently, in the case of eye contact, flush abundantly with water, and if irritation persists seek medical advice. Inhalation – continued exposure should be prevented.
- 4) **Sealing Rope** - Wear gloves, overalls, in the case of an irritation rinse the affected area with water and wash gently, in the case of eye contact, flush abundantly with water, and if irritation persists seek medical advice.

**Potterton Commercial Customer
Erection/Assembly Check List**

The items listed below have been put together as a guide to what actions should be completed before the erection/assembly of a boiler takes place.

- I. Site access available for persons carrying out the proposed work.
- II. Site Managers/Personnel aware that work will be taking place.
- III. Risk Assessments carried out on possible risks which may effect the persons carrying out the proposed work.
- IV. Sections and fittings boxes were applicable should be positioned adjacent to the plinth(s) within the boiler house prior to persons

carrying out the proposed work, attending site. As this will eliminate one source of on site injury taking place, if this is unable to be done notice prior to attending site should be given.

- V. When boilers are to be stripped and rebuilt, labour and transport should be provided for moving the sections from the delivery point to the final erection point. If this is unable to be provided notice prior to attending site should be given.
- VI. Sections/casing etc, should be kept in a clean and dry area prior to erection/assembly.
- VII. Water should be available.
- VIII. A drain off area should be available.
- IX. Power should be available.
- X. A site representative should be available at all times.
- XI. Clear instructions supplied to the persons carrying out the proposed work regarding positioning the boiler.
- XII. Fire evacuation procedures, facilities availability, specific Health & Safety information, etc, should be provided.

Items VII to X are essential if boilers require pressure testing.

Heat Exchanger Assembly

Models 5 section to 16 section come delivered with the heat exchanger already assembled. The control panel, gas train and casing are packed separately and clearly labelled.

Models 17 section to 22 section are delivered unassembled. The flue hood, gas train, burners, casing and control panel are delivered on one pallet.

Provided below is a detailed assembly instruction procedure for erecting the boilers. It is advisable to read the instructions fully before starting assembly.

Assembly of Boiler Block

Remove the shrink wrap and metal straps securing the components to the pallet. Identify the bag of fasteners, thermostat pocket and spacers, ceramic rope, glue and Vaseline packed in the casing box.

Clean the sealing ring ports on the sections with a dry rag, DO NOT use oil or any other compound. Check that the sections are clear of swarf, sand or any other debris.

The heat exchanger consists of three types of sections these being the left hand section (L), the middle section (M) and the right hand section (R). (Fig 3).

Fit the M10 studs (shorter thread) into the tapped holes in the sections (Fig 4).

Fix the outlet manifold (D) (it has four 1/2" holes (C)) to the right hand section using one of the assembly plates (A) (Figs 5 & 6).

Note: Ensure that the outlet is on the side, which has been specified.

Fix it to the left hand section in the same way (Fig 7).

Add the sealing rope to the left hand side of the sections. The rope is pre-cut to two different lengths, one for the front and one for the back and should be glued with the adhesive provided and trimmed to length if necessary (Fig 8 & 9).

WARNING: The adhesive gives off a flammable vapour and skin and eye contact should be avoided.

If the adhesive comes into contact with: -

- a) SKIN – then resin removing cream should be used and not a solvent to remove it.

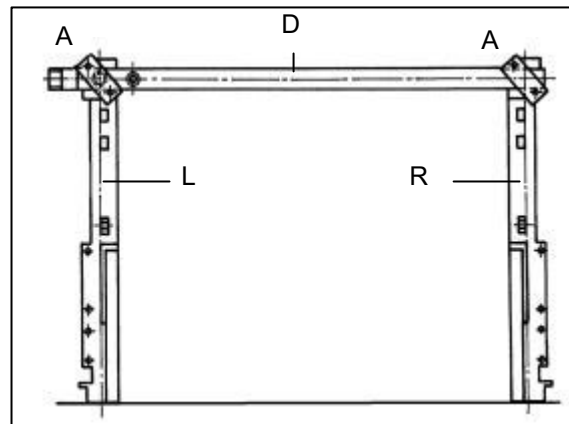
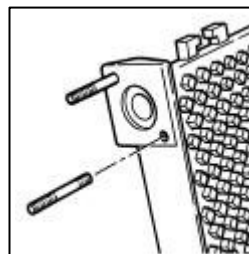
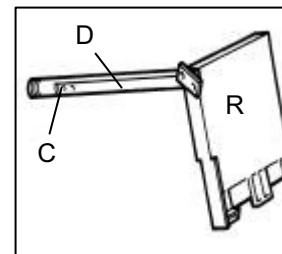
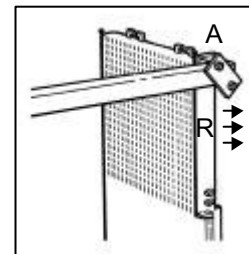
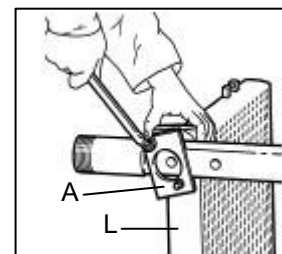
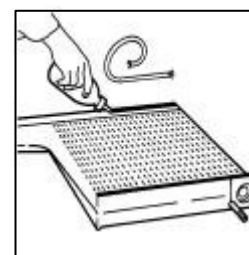
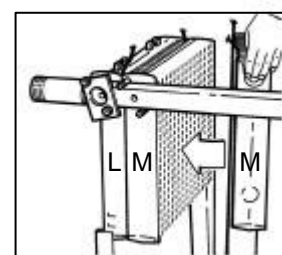
Fig 3**Fig 4****Fig 5****Fig 6****Fig 7****Fig 8****Fig 9**

DERWENT PRESTIGE

- b) **EYES** – the eye should be irrigated with water and medical treatment sought.
- c) **INHALATION** – continued exposure should be prevented and the user should be removed to open air and if necessary medical advice sought.

The adhesive should be used sparingly as it is only used to keep the rope in position until the sections are clamped together.

The end sections should be at right angles to the floor and sitting on steel strips required under the section feet (see fig 2 page 5).

The sections should be spaced so that the distance between the centres of the end sections are as Dimension B + 20mm in Fig 10, it is essential that this dimension is maintained at the top and bottom, otherwise the bottom feet of the end sections may toe in and this will make fitting the base tray difficult. The boiler should now be sitting in its final position to avoid further movement when fully assembled.

Take an intermediate section and hang it on to the front manifold against the left-hand end section taking care not to snag and pull off the sealing rope. Add all of the intermediate sections until the last one is in place.

While maintaining continuous pressure on the right hand section in the direction shown by the arrow (Fig 11) slacken the assembly plate "A" slightly to enable the final section to be moved up then retighten the clamping plate.

Fit the 3 tie bars, one at the front and two at the back. Loosen the two clamping plates, fit the base tray in position and tighten the tie rods on the boiler up to dimension B Fig 10.

Check this dimension carefully and check that the sections are at right angles as shown in (fig 12).

Fit the return manifold (E) (Fig 13). Centering the 3/4" hole (drain) positions the manifold accurately with respect to its clamping plate (F).

Fit the clamping plate using just 2 nuts at each end.

Fitting the Seals

Pull the return manifold about 15 to 20mm away from the cast iron heat exchanger using a lever (chisel or screwdriver). Insert the seals at an angle, locating the bottom in the recess and letting the top rest against the manifold (Fig 13 & 15).

Fig 10

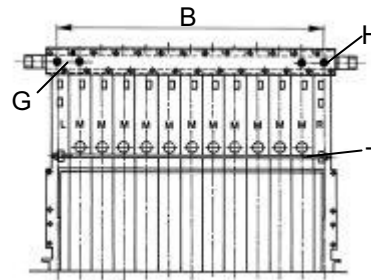

No. Of Sections	B (mm)
5	324
6	405
7	486
8	567
9	648
10	729
11	810
12	891
13	972
14	1053
15	1134
16	1215
17	1296
18	1377
20	1539
22	1701

Fig 11

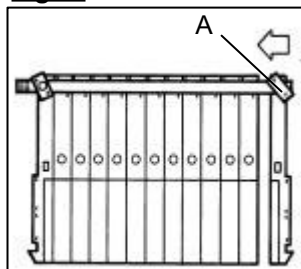

Fig 12

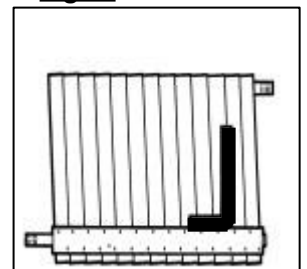

Fig 13

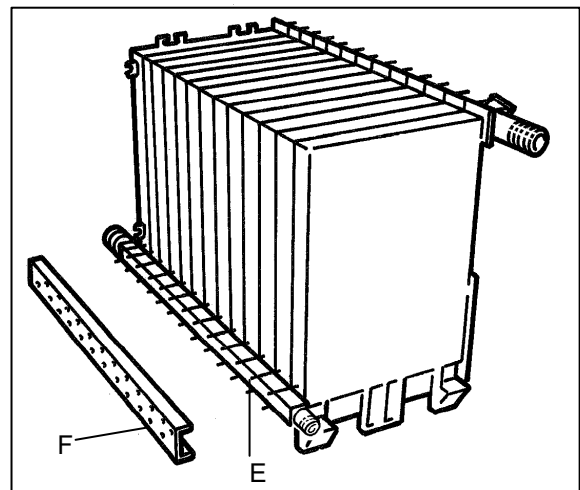

Fig 14

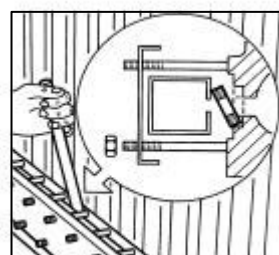
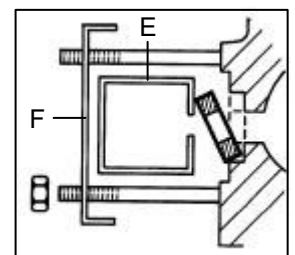

Fig 15



NOTE: Do not use glue or mineral grease that might attack the EPDM seals. Only the Vaseline supplied should be used in contact with the seal.

Fit the washers and nuts and tighten until the seals are in contact, but without clamping the manifold. Ensure that the tie rods (T) are taking the strain and then remove the assembly plates "A" from the outlet manifold and fit the clamping plate (G Fig 10).

Fit the seals in the same way for the outlet manifold (Fig 14 & 15).

Once the heat exchanger has been assembled, but not clamped, the sections can be shaken down by tapping repeatedly on the sides.

Check Once Again:

- That length B at the tie rods is correct.
- That the manifolds are correctly positioned (holes centred in the clamping plates)
- That the return manifold is at right angles to the sections.

Tighten all the nuts on the manifolds evenly.

Fit the temperature monitoring sleeve in the ½" hole (H) in the section (8) nearest the outlet.

Fit the drain tap to ¾" hole in the return manifold.

Combustion Chamber Base Plate

Put an insulating sealing strip on the bottom right and left edges of the combustion chamber (Fig 16) and put an insulation strip on top at the back edge. Insert the base plate with the front fold downwards, being careful not to damage the seals and ensure a good seal.

Hydraulic Test of Boiler

This is to be carried out on boilers assembled on site or where water manifolds have been disturbed.

Fit a hydraulic test pump to the return manifold and fit a valve to vent air from the flow connection. Fill the boiler with cold water and, in accordance with BS 779, 1976 pressurise up to 1.5 times the system design pressure, ie. 7.5 bar maximum, and observe for 30 minutes.

Fig 16

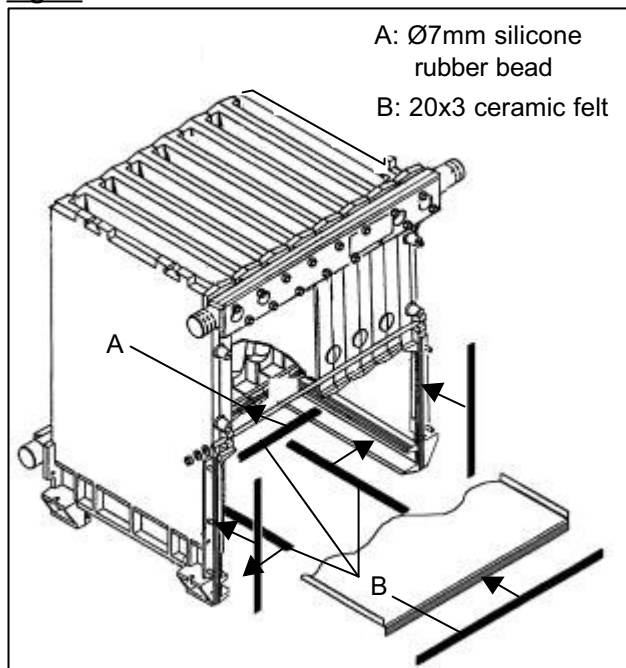

INSTALLING MULTIPLE UNASSEMBLED BOILERS

When two boilers are being built side by side with the minimum practical clearance between them and with one flow connection to the left and the other to the right, the end sections should be positioned on the base as shown in Fig 17.

Fig 17

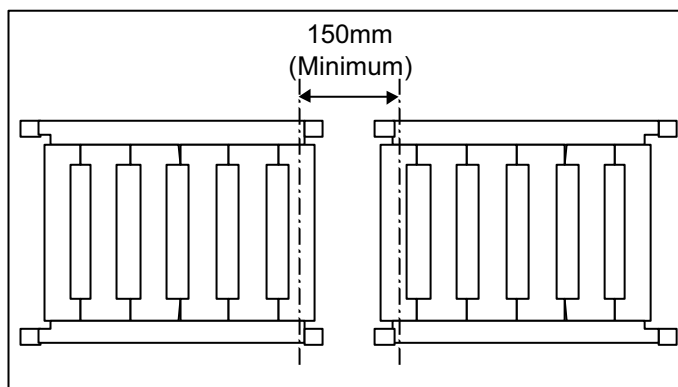

FITTING OF BURNER ASSEMBLY 17 to 22 SECTION.

Stage 1: Fold the pieces of insulation as Figure No 1 and then fit the pieces of insulation firmly in between the sections legs at the rear of the boiler. See figure No 2



1



2

Stage 2: Clean the base tray-mounting seat and fix the sealing strip with the adhesive provided. See figures 3 / 4 / 5.



3



4



5

Stage 3: Insert the base tray inside the combustion chamber See figures 6 / 7.

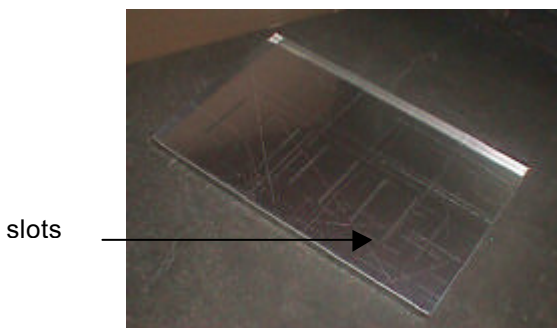

6



7

Stage 4: When the base tray is in position fit the sealing tape on the front edge of the base tray using the adhesive and sealing tape provided See figures 8/ 9 /10.



8



9



10

Stage 5: The complete burner assembly can now be fitted to the boiler by locating the burner assembly on to the studs on the end sections See figures 11 / 12

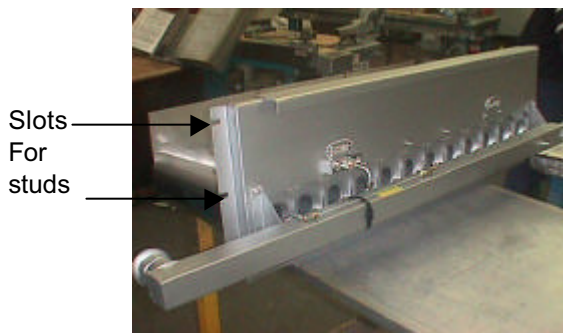

11

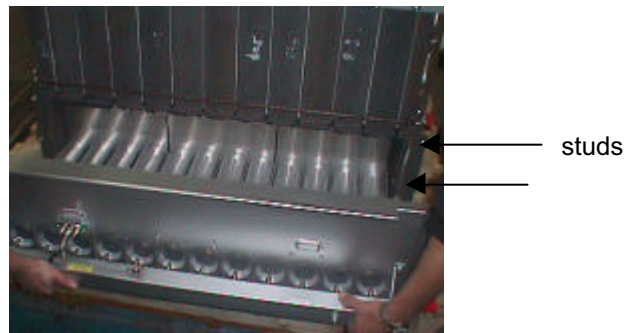

12

6: Connect the pilot tube of 4mm diameter to the 6mm pilot tube elbow and on to the gas valve by the BANJO Stage Connection See figures 13 /14

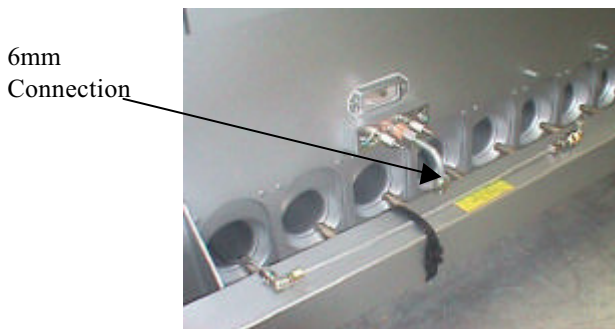

13

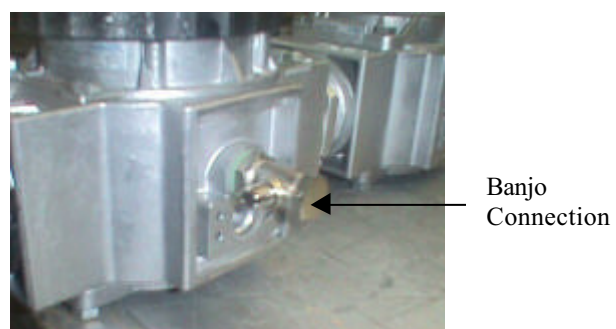

14

Boiler Maintenance

It is essential that when the maintenance of the boiler takes place that the pieces of insulation are inspected and if they are showing any signs of deterioration they should be replaced. Please refer to Boiler Maintenance on section 4 Page 29.

DERWENT PRESTIGE

Fitting of Flue Hood and Burners

Fit the rear panel of the casing before the flue hood.

The flue hood is fitted onto the top of the boiler block and a seal must be made using the ceramic felt provided, between the sections and the flue hood.

Take the roll of ceramic felt packed with the boiler and cut a strip and glue it across the front end of the sections. Next cut two pieces of sealing strip to form the side seal (I) on top of each end section see Fig 18.

Finally add the rear sealing strip. This sealing strip does not sit on the top of the end sections but underneath the lip at the back of each section.

Fix the hood using the clamping plates (K) (Fig 18). Ensure that there is a good seal made between the back of the heat exchanger block and the flue hood. See Page 21 for handing the gas manifold.

Burner Manifold

The burner manifold (T) can be fitted with the gas inlet on the right or left. It is fixed to the front panel (U) by four nuts and washer spacers supplied (Fig 18).

Note: on the 12 to 22 section boiler the gas train and the return cannot be on the same side of the boiler.

Combustion Chamber Front Plate

Bond the silicone rubber foam strips to the right and left hand sections of the heat exchanger delivered unassembled and bolt to the front plate (U) to these sections (Fig 16). Use the nuts and washers supplied. Put an insulating sealing strip on the front fold of the base plate. The base plate is not screwed to the front plate (U) of the burner.

Gas Train

The gas train (X) is delivered assembled and prewired to be fitted to the right or left. It is connected to the connector on the gas burner manifold by a union (Y) (Fig 18). Remove the cap from the appropriate connector Y and tighten the free part of the union, using a flat washer to seal the joint. Fit the pilot light assembly to the appropriate side (Z or Z') this **MUST** be fitted on the same side of the burner plate as the gas train. Fit the pilot light supply tube. For connection see "Gas Supply".

Handing

Flow & Return

On the 20 and 22 section boilers the flow and return connections **must not** be made on the same side of the boiler – they **MUST** be diagonally opposite. On the 12 to 22 section boilers the return and the Gas Train cannot be on the same side.

Fig 18

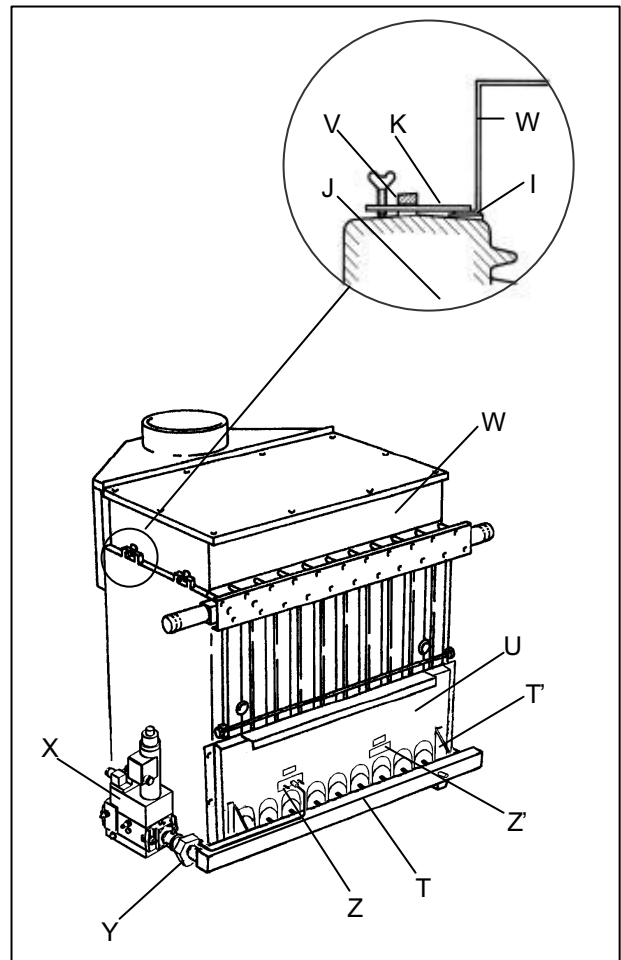
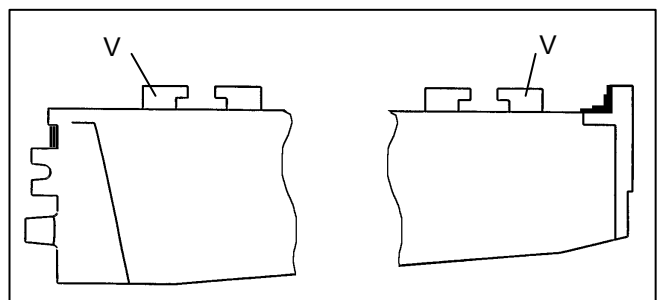

Fig 19



Assembly of Casing (5 to 8 Section)

(The following description should be read in conjunction with Figs. 20 and 21)

1. For the 5 to 8 section boilers, the insulation is wrapped around the boiler. It is stapled at the back and held by a bracket on the right and left.
2. The rear panel (item 1) and the internal front panel (item 2) are delivered mounted directly on the boiler. These will need to be loosened slightly to allow alignment of the side and top panels.
3. Fix the right hand rear panel (item 3 by fixing it onto the front and rear panels (items 1 & 2).
4. Repeat for the left hand rear side panel (item 4).
5. Fit the control panel locating bracket (item 11) onto the support panel (item 5) and fix to the front edges of the right and left rear side panels (item 3 & 4).
6. Attach the control panel (item 6) directly to the mounting plate using the studs and the two clamping screws on the control panel mounting plate (item 5).
7. Secure the earth wire from the heat exchanger to the bottom right hand side of the control panel and proceed with the electrical wiring (see boiler wiring diagram on page 33 & 34).
8. Put the insulation on the top of the fluehood, run the 230V cable for the control panel in the right hand channel and the wiring for the sensors through the left hand channel and fit the top (item 9) on the studs. There is a notch at the back of the side panels to help position the top.
9. Tighten the nuts on the back plate (item 1) and the internal front plate (item 2).
10. Fit the front right hand side panel (item 7) to the side panel (item 3) and the control panel (item 6).
11. Fit the front left hand side panel (item 8) to side (item 4) and the control panel (item 6).
12. Screw the door chains to the brackets.
13. Fit the brackets for the quarter turn locks to the front left and right hand panels using nuts.
14. Fit the quarter turn locks to the door (make sure that the clips are fitted correctly).
15. Fit the door (item 10), attach the chains, connect the earth wire from the door earth wire from the door earth terminal (bottom right of the door) to the earth terminal on the base of the front right hand panel and close it using the quarter turn locks.

Fig 20 General Arrangement of Casing (5 to 8 Section)

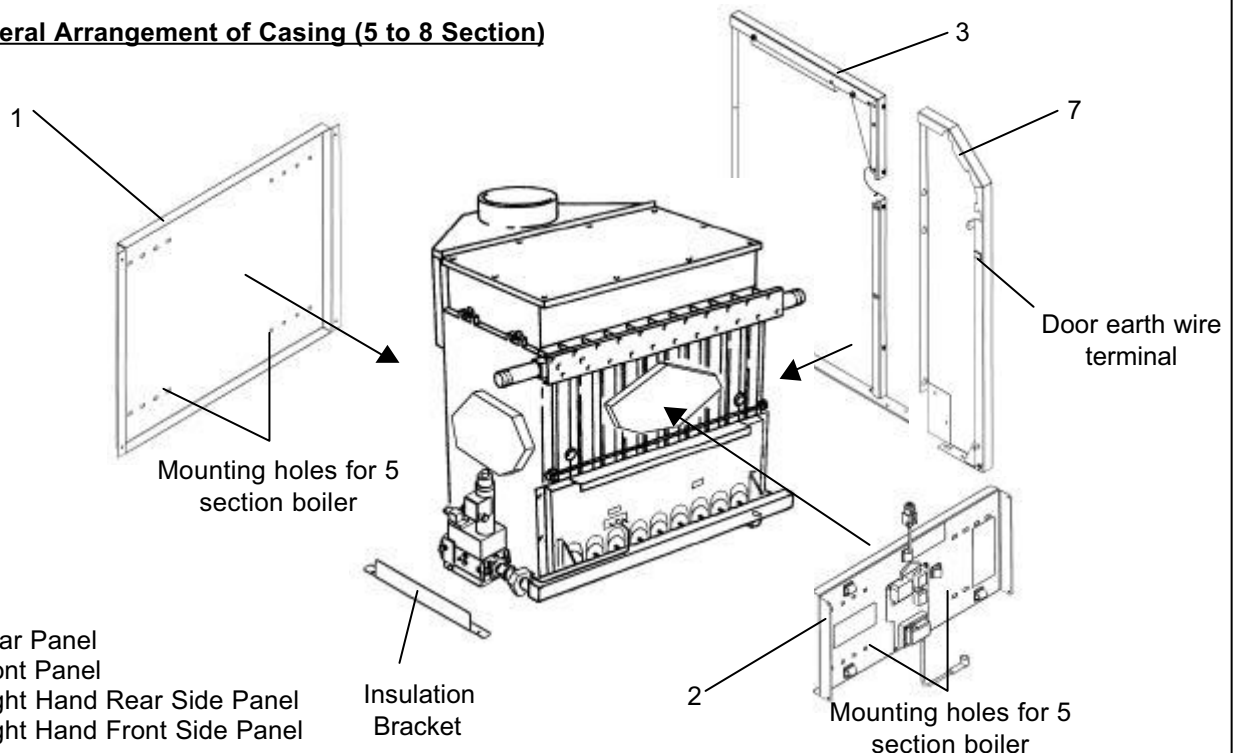

DERWENT PRESTIGE

Fig 21 General Arrangement of Casing (5 to 8 Section)

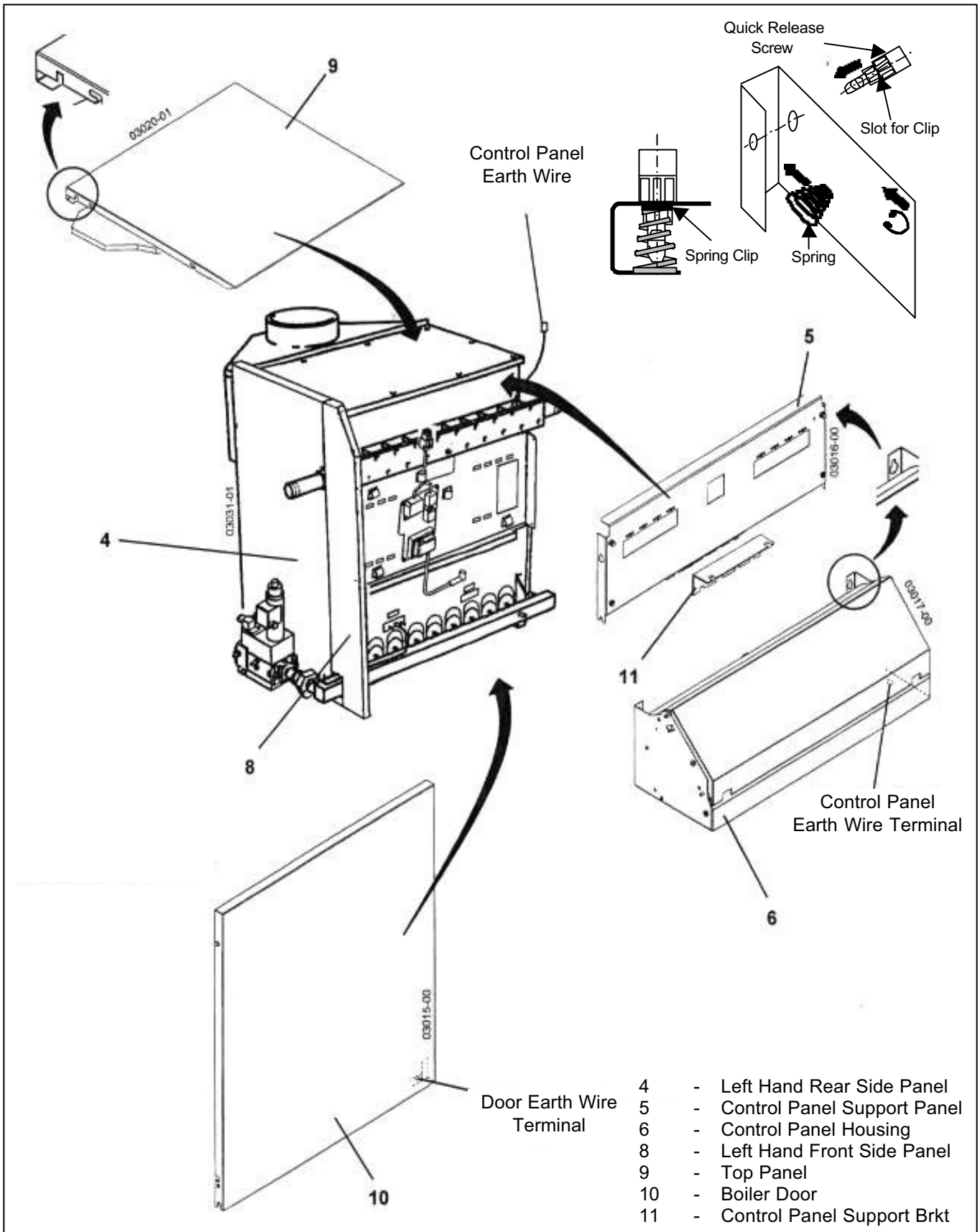

- | | | |
|----|---|-----------------------------|
| 4 | - | Left Hand Rear Side Panel |
| 5 | - | Control Panel Support Panel |
| 6 | - | Control Panel Housing |
| 8 | - | Left Hand Front Side Panel |
| 9 | - | Top Panel |
| 10 | - | Boiler Door |
| 11 | - | Control Panel Support Brkt |

ASSEMBLY OF CASING [9 to 22 section]

The following description should be read in conjunction with Fig.22 & 23.

1. On the 9 to 22 section boilers the insulation is fixed by the front and rear panels. The sides are insulated with insulation glued onto the side panels.
2. Position the rear insulation between the draught diverter and the heat exchanger and secure it in place with the right hand rear panel (item 1) mounted on the heat exchanger. Do not tighten the screws fully until side panels have been fitted.
3. Repeat for the left hand rear panel (item 2).
4. Fit the draught diverter (if delivered separately).
5. Position the front insulation and hold in place by screwing the right hand boiler front panel (item 6) to the heat exchanger. Do not fully tighten the screws.
6. Attach the connector strips (items 3 and 4) to the right hand front panel attached to the boiler.
7. Fit the left hand boiler front panel (item 5) to the connector strips and screw to the heat exchanger.
8. Fit the right hand rear side panel (item 3) to the front and rear panels already attached to the boiler.
9. Repeat for the left hand rear side panel (item 8).
10. Fit the control support panel (item 9) to the front edges of the right and left rear side panels previously fitted.
11. Hang the control panel (item 10) towards the right hand side of the support panel using the locating pin and two fixing screws provided. (It will not be possible to attach the left hand side).
12. Fit the extension panel (item 11) onto the left hand side of the support panel using the locating pins and fixing screws provided. Secure the extension panel to the control panel with one screw through the inside of the control panel.
13. Fix the earth wire from the heat exchanger to the bottom right hand side of the control panel and proceed with electrical wiring (see boiler wiring diagram on page 33 and 34).
14. Place the top insulation panel on the draught diverter before fitting the top panel (item 16).
15. Tighten the screws on the front and rear panels.
16. Fit the right hand front side panel (item 7) onto the rear sided panel (item 3) and the control panel.
17. Fit the left hand front side panel (item 13) onto the rear side panel (item 8) and the control panel.
18. Mount the quick release fixing brackets (with chain already attached) onto the front side panels (items 7 and 13).
19. Assemble the door quick release door fixings as in step 13 under "5 to 8 Section Casing Fitting).
20. Position the door near the front side panels and attach the earth wire from the bottom of the front side panel to the bottom door fold using the push clip provided. Hang the door on the bottom hinge bolts and attach the right and left hand restraining chains in the holes in the door top fold.
21. Close the door and secure the quick release screw using a screwdriver.

Fig 22 General Arrangement of Casing (9 to 22 Section)

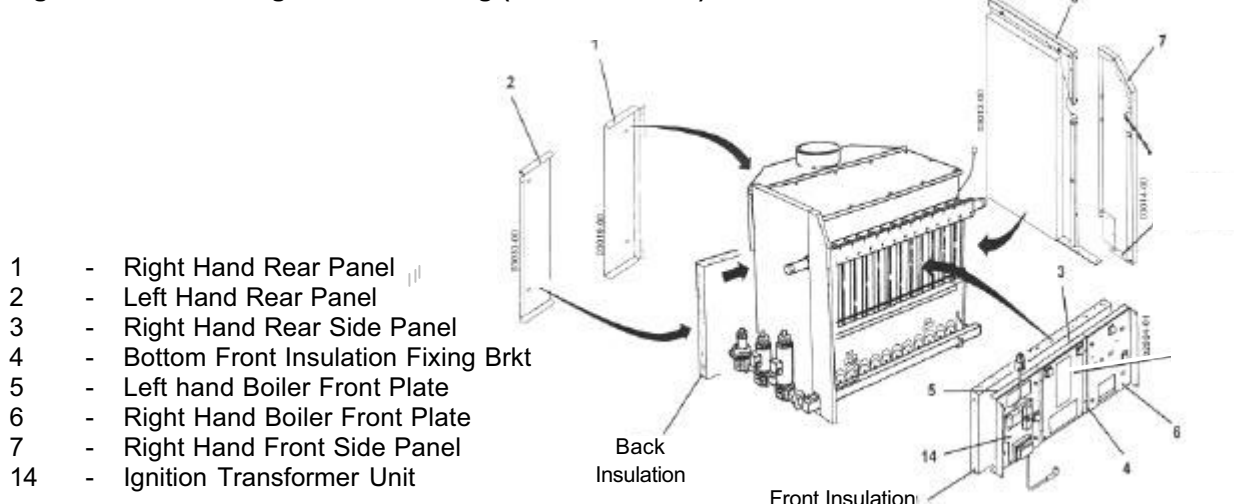

DERWENT PRESTIGE

Fig. 23 General Arrangement of Casing (9 to 22 Section)

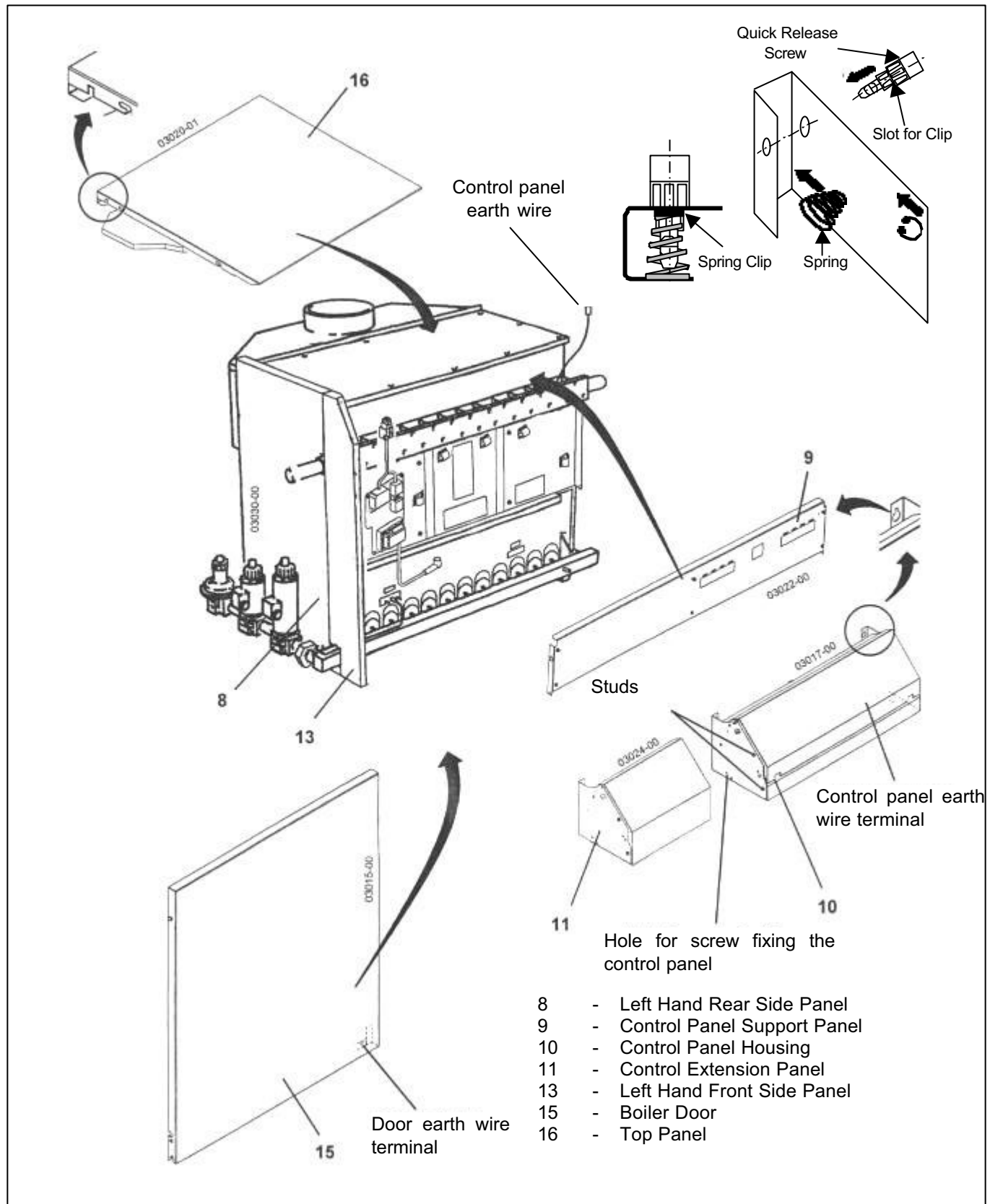
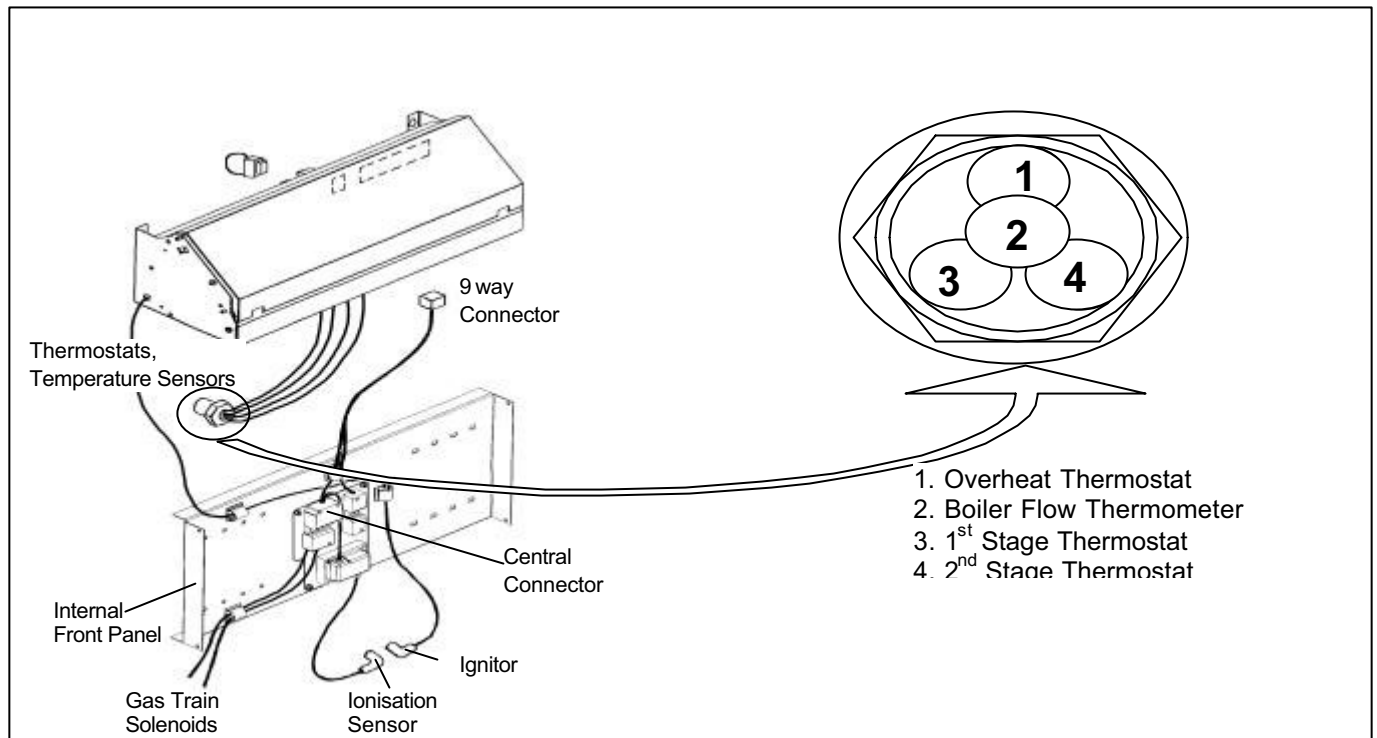

Fig 24 General Arrangement of Thermostat Pocket**Connecting the Water System**

The flow and return connections should be made to the appropriate manifolds.

For 20 and 22 section boilers the connections should be made to the flanges provided which are fitted to the manifolds.

It is essential that all pipework connections to the boiler are self supporting, correctly aligned and allow for free expansion of both boiler and pipework.

Care should be taken in the pipework design to prevent strain on the connections. Excessive strain can lead to premature failure of the boiler, which is obviously outside the terms of our warranty.

The use of expansion bellows to take up both axial and lateral movement is recommended.

Connecting the Electrical Supply

The electrical supply should be 230V 1Ph 50HZ. A 6.3A fuse and a suitable two pole isolator having a contact separation of at least 3 mm in all poles has to be provided by the installer for isolation of the boiler. All on site wiring shall conform to I.E.E. Regulations.

The supply should be made to the right hand side of the boiler control panel by flexible conduit. (This can be achieved by removing the two screws from the front top corners of the control panel and hinging control panel front down and all the electrical connections can now be seen)

The entry should be made by a spare bulkhead connector on the control panel. The bulkhead

connectors can be switched from one side to the other and blanking caps should be fitted over the unused entry holes. The blanking caps should always be used to cover spare holes.

Assembling the Gas Train

The live, neutral and earth connections should be made to the control panel terminal block. The earth connection should be made 50mm longer. The length of the conductors between the cord anchorage and the terminals must be such that the current carrying conductors become taut before the earth conductor if the cable or cord slips out of the cord anchorage. The wiring diagram is included in this manual on page 33 & 34 and also on the front inner panel of the boiler.

For multiple boiler installations each boiler shall have an isolator and fuse as detailed above to protect the boiler and allow for maintenance.

Connecting the flue

The fluehood has a vertical female outlet into which the flue should be fitted and sealed fitted (dimensions given in General Data). It is recommended that twin walled flue is used.

BOILER DISASSEMBLY

If the boiler has to be disassembled it should be noted that the sections are not self-supporting. Remove the return manifold only, and then remove the sections individually from the flow manifold

DERWENT PRESTIGE

The boiler is supplied with a Dungs gas train for high/low operation.

Remove the gas train from its box and remove the boiler door. (The pilot supply pipe is also in the box with the gas train).

The pilot is supplied fixed to the burner for the left hand gas train arrangement.

If the gas train is to be fitted on the right hand side, swap the pilot over to the right hand side. The pilot is secured by two studs, washers and nuts. A blanking plate is similarly fastened to the redundant pilot mounting hole and should also be swapped over.

Remove the plastic plugs in the gas train union and fit to the union on the burner manifold. Make sure the rubber seal is fitted in the union it can be found attached to the gas valve.

If the gas train has to be fitted on the right hand side, the burner manifold should be changed over first.

NOTE: The gas train is not self-supporting and must be supported with the main gas pipework.

Fig 25 General Arrangement of Pilot Burner

Connecting the Pilot Gas Line

The pilot line is of sufficient length and is fitted with an isolating valve.

A piece of tube is supplied in the gas train box. This is connected to the pilot burner and the pilot line by compression fittings.

Put the cap nuts on the tube then the olives and position both pipe ends right into the fittings before tightening.

Tighten the fittings together and do not use pipe jointing compound on these connections.

Finally connect the gas train plug to the boiler plug on the front panel.

Plug the ignition lead into the ignition probe, then cut the ionisation lead to the required length. (see table below for details).

No. of Sections	Wire Length with Left Hand Gas Train	Wire Length with Right Hand Gas Train
5 to 8	1700mm	1700mm
9 to 11	1900mm	1700mm
12 to 14	2100mm	1600mm
15 to 17	2300mm	1600mm
18 to 22	2600mm	1600mm

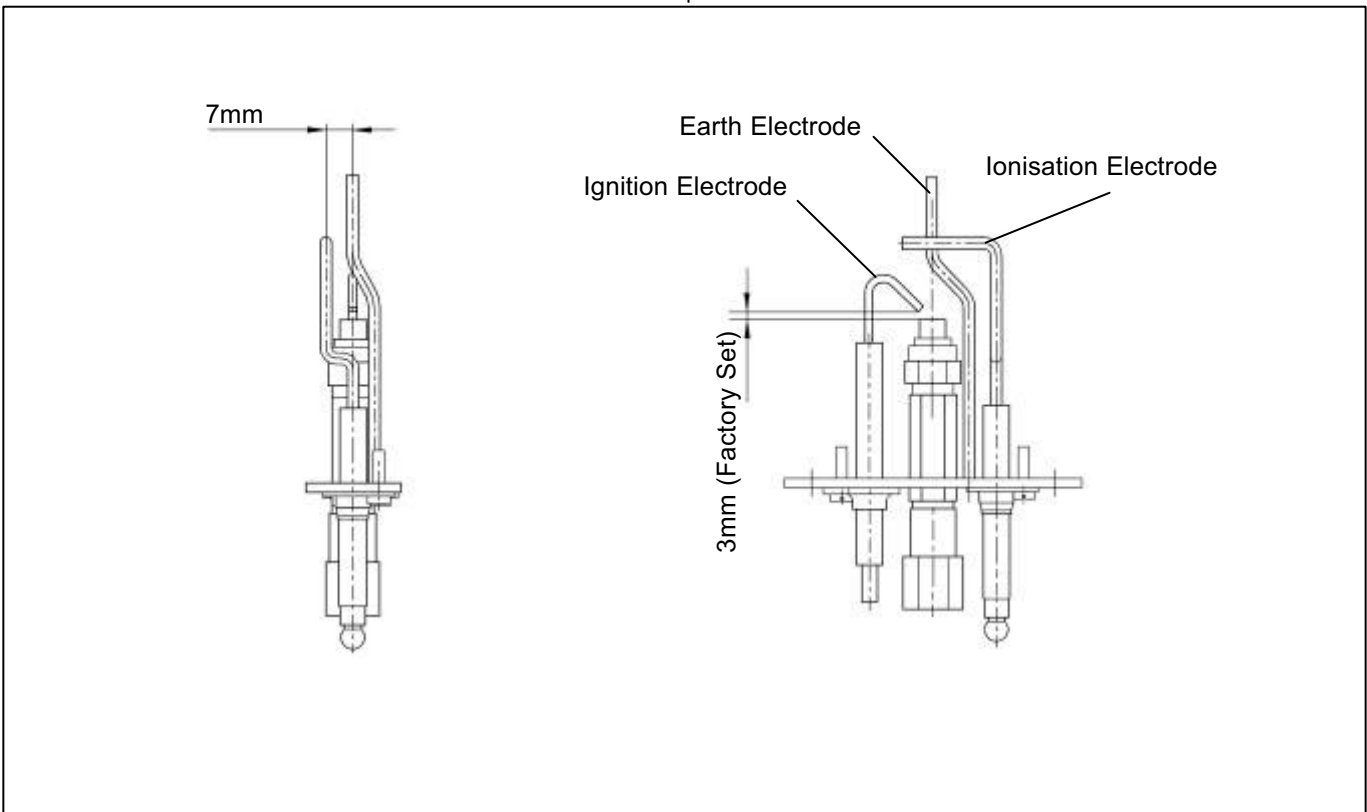

Connecting the Gas Supply

The connection should be made to the female connection (size given in Table 2 page 1). A union and isolating valve should be fitted close to the boiler to allow disconnection of the boiler controls for maintenance and repair.

The gas supply should be made through a suitable meter and the local gas undertaking should be consulted to determine the suitability of the meter and the gas supply to meet existing and additional demands for gas.

The installation shall be made in accordance with the requirements of the Gas Safety (Installation & Use) regulations and all other Regulations and Codes of Practice given on page 6.

In particular, before connecting the boiler, ensure that the gas supply has been purged of air and a manual valve for isolation of the boiler is fitted in an accessible position, readily identifiable, adjacent to the boiler.

The gas supply should be supported adequately.

For large single and multiple boiler installations consideration should be given to the installation of additional gas meters to assist in the monitoring of boiler performance.

Attention is drawn to the need for adequately sized pipework according to the maximum gas demand for multiple boiler installations and each boiler shall be provided with an isolating valve so that it is possible to isolate the boiler from a common gas supply for maintenance purposes.

Boosters will not be necessary if a minimum inlet pressure of 17 mbar can be provided at the inlet to each gas train and maintained during full load conditions. If a booster is required the Local Gas Undertaking must be consulted and the booster shall be fitted with a low pressure cut off switch upstream of the booster in the event of reduced pressure and to prevent automatic restart on pressure restoration. The cut off pressure shall be decided by the Local Gas Undertaking.

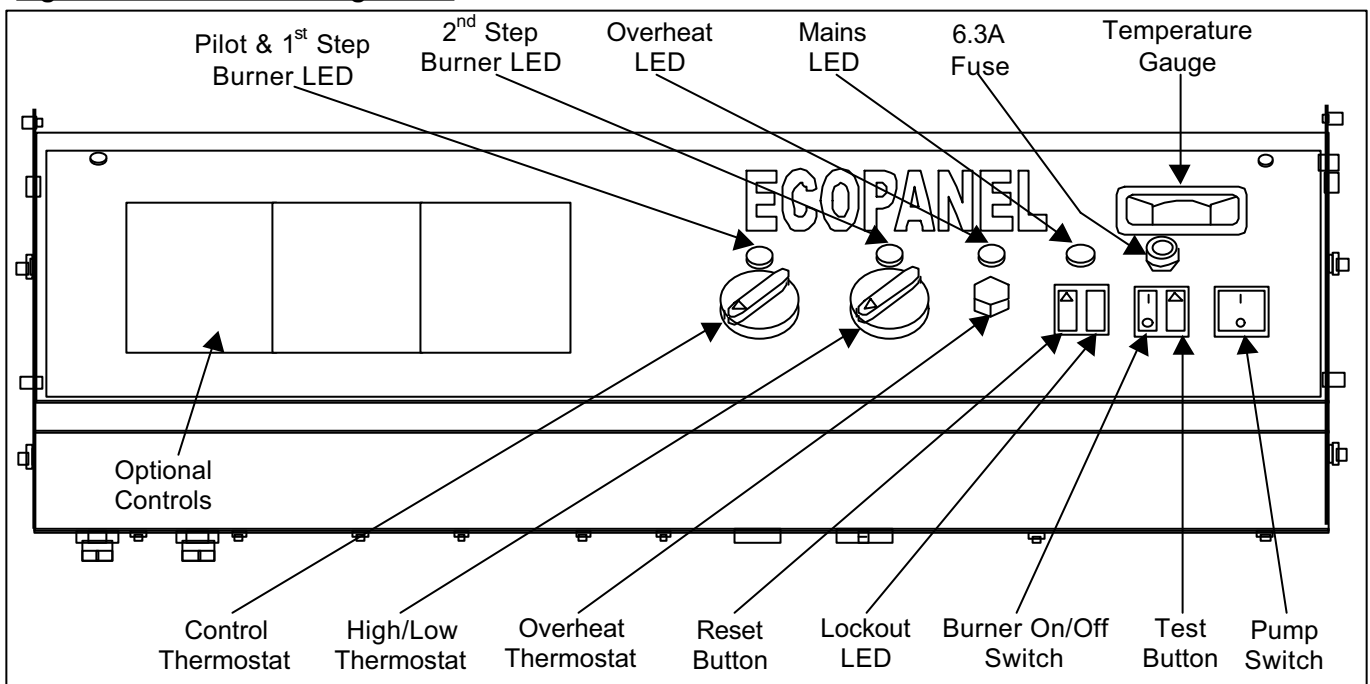
Fig 26 Control Panel Configuration**Boiler Controls**

The operation of the boiler is under the control of its own control box, boiler high/low and overheat thermostats.

In addition, the boiler should be controlled by a time switch, frost thermostat, pump overrun facility and, for multiple boiler installations, a boiler sequence controller. The boiler can be controlled by removing

links D to G and providing a switch across these terminals to switch the boiler (Note this does not switch the pump circuit). Safety Interlocks are provided across R & K, for pressure switch etc.

The high limit thermostat and burner lockout signals can be picked up from terminals marked remote indication. These are volt free contacts.

See boiler wiring diagram, page 34 and 35.

DERWENT PRESTIGE

**Potterton Commercial Customer Commissioning
Check List**

The items listed below have been put together as a guide to what actions should be completed before the commissioning of a boiler takes place.

1. Site access available for persons carrying out the proposed work.
2. Site Managers/Personnel aware that work will be taking place.
3. Boilers correctly erected and cased.
4. Risk Assessments carried out on possible risks which may effect the persons carrying out the proposed work.
5. Site wiring complete to boilers.
6. Boilers filled & vented.
7. Controls connected, operable and calling for heat.
8. Sufficient system heating load available to run the boilers in order to complete combustion checks.
9. All system pumps operational and available.
10. Gas supply completed, purged and ready for use.
11. Flue system complete, adequate and fully functional.
12. Permanent ventilation complete and adequate.
13. All safety systems fitted and fully operational (e.g. safety valves, fuel shut off devices, flue fans interlocked, etc.)
14. Safe working environment provided.

Contravention of Regulations

PLEASE NOTE THAT SHOULD ANY ITEMS BE INSTALLED ON A TEMPORARY BASIS, E.G. VENTILATION, FLUES ETC, THEN THE COMMISSIONING ENGINEER WILL NOT BE ABLE COMMISSION THE BOILER.

COMMISSIONING

IMPORTANT: The boiler must be commissioned following completion of installation. Operation of an uncommissioned appliance may cause injury to personnel and damage to the boiler/burner unit and could invalidate the manufacturer's warranties.

Commissioning should only be carried out by personnel approved and competent to do so. This facility is available from Potterton Commercial Service Offices at the addresses as listed on the back page of this manual.

Before commencing to commission ensure that any cling film is removed from the casing panels and then check the following.

1. Electrical supply is of correct voltage and polarity and earthing is available with certification that all electrical checks have been carried out.
2. Gas supply is tested for soundness and purged of air. Ensure that the burner is suitable for connected gas supply and pressure.
3. Test for gas soundness of gas trains as described on page 25.
4. Appliance gas cocks are all turned off.
5. Gas supply is turned on at the meter.
6. Boiler and system are filled with water and operating pressure is within appliance range.
7. Flow and return valves are open.
8. Any external controls and the on/off switch are in the "ON" position.
9. The circulating pumps are operational. Check that the pump is scheduled to run and not on pump overrun if the boiler has previously been fired. Check that any flow proving interlocks are functional.
10. Check that the high limit thermostat has not tripped by pressing the green reset button underneath the hexagon cap nut on the fascia.
11. Ventilation is adequate and, in the case of mechanical ventilation systems, operation of the boiler is inhibited unless the ventilation fan is proved.

12. On mechanically assisted flue systems the operation of the boiler plant should be inhibited unless the mechanical flue system is operational and flow proved.
13. The safety valve should be checked to ensure that it is the correct size and pressure.-
14. The cold feed and open vent sizes should be checked.

Following completion of the above checks the burner should be commissioned. Typical combustion figures are detailed below. The combustion figures, etc. should be completed on the commissioning form provided at the back of this manual and returned to Potterton Commercial at the address on the back page.

Commissioning figures should be taken at a boiler flow temperature of 80°C. The combustion measurements should be taken in the secondary flue at a minimum of 600mm above the draught diverter.

GAS

CO ₂	-	6 - 7%
CO	-	0 – 50 ppm
Flue Gas Temp	-	130 – 160°C

IMPORTANT: The boiler/burner units are manufactured in accordance with the company Quality Assurance plan registered to meet the requirements of ISO 9000. A condition of this supply of the appliance for compliance with this Quality Assurance plan is the return of the appliance commissioning report.

Important – Safety

In the U.K it is a legal requirement that when working on gas appliances the engineer must be CORGI registered. The manufacturer cannot be held responsible for any consequential damage, loss or personal injury as a result of customers failing to follow these instructions, or as a result of misuse.

Emergency Instructions

The burners are designed and constructed to meet all of the essential requirements of the GAS APPLIANCE DIRECTIVE 90/396/EEC and under normal circumstances should not give occasion to any hazardous conditions. If such a condition should occur during commissioning or subsequent use of this product, be it a fault of the boiler or of any instrument, machine or service in the proximity of the burner then the GAS and ELECTRICITY supply to the burner should be **IMMEDIATELY ISOLATED** until such time that the fault has been investigated and rectified.

IMPORTANT After each adjustment, gas flow rate and flue gas analysis should be re-checked.

ALWAYS Use approved test equipment (Continually monitoring electronic equipment is recommended).

NEVER rely on a visual inspection of the flame as a guide to combustion quality.

Following/during commissioning of the burner unit the following additional checks should be carried out.

1. Operation of the control, high/low and high limit thermostats should be checked for correct operation.
2. The flue draught available at the appliance flue outlet should be checked under all operating conditions (hot and cold) and should be within the boiler operating parameters, see Table 3 & 4 (pages 2 & 3)).
3. The fuel supply to the appliance should be isolated and the burner operated to ensure safety shut down and lockout of the burner on flame failure.
4. Shut down of the boiler plant by external controls does not cause a hazardous condition and pump overrun is provided to remove residual heat from the boiler.
5. Following commissioning the boiler overheat and control thermostat should be set to the required operating setting.
6. Following completion of commissioning the soundness of all automatic fuel valves should be checked for leakage.

Additional Checks

Where possible the system should be checked to ensure that following purging of air there is no raw water make-up. In particular, when the system is operated in the hot condition, there should be no discharge of water from the safety valve, open vent or cold feed tank overflow that would otherwise lead to unregulated raw water make-up when the system cools down.

Pre-Lighting

Before attempting to light the boiler start the circulating pump and check that it is scheduled to run and not on pump overrun if the boiler has been fired previously.

DERWENT PRESTIGE

Check that the main and pilot gas cocks and electrical supply are turned off.

Set the boiler control thermostat to the required position and the time clock to the "ON" position. Check that the high limit thermostat has not been tripped by removing the hexagon cap nut and pressing the button beneath it.

Start the boiler by switching on the main isolator and the on/off switch on the boiler control panel fascia and the boiler will attempt to light. After a delay of approximately 15 seconds the ignition spark should be heard and after 5 seconds the control box should lock out.

If the ignition spark is not detected or the control box does not lock out see Fault Finding on page 30.

Commissioning Live Run

1. Turn on the appliance isolation valve.
2. Check the inlet pressure, which should be at least 17 mbar, on the inlet test pressure point and note the value.
3. Close the pilot supply gas cock and check that the pilot pressure is zero and not moving.
4. Turn on the electricity supply at the main isolator and at the on/off switch on the control panel fascia (ensuring that time clocks and any other external controls are made or are in the "ON" position), also turn on the pilot isolation valve.
5. Approximately 15 seconds after switching on, the ignition spark should appear followed by ignition of the pilot burner. If pilot flame is not established the control box will lockout, the red lockout light on the control panel will illuminate. This may initially occur due to air in the pilot line.
6. The control box may be re-set after a delay of one minute by pressing the red button on the control panel and the red light will go out. When the flame is established and the main burner is lit, check the gas pressure on the gas manifold pressure nipple and adjust the regulator (located on the gas valve see page 30) to give a pressure of 16.5 mbar. An ignition spark should start followed by lockout.
7. The pilot burner will re-light followed 10-15 seconds later by the main burners.
8. For high/low operation the low fire rate must be set first. To set the low fire rate the boiler temperature must be raised above 40°C (ie above the minimum operating temperature of the second

stage thermostat). With a pressure gauge fitted to the burner manifold (PTP5), turn the control thermostat down until it clicks. Observe that the burner flames have diminished. Adjust the low fire rate (see page 26) until the burner manifold pressure is 10.6 mbar. Operate the burner at high and low fire checking that the burner manifold pressure is correct and that the flame is stable and blue.

9. Test the gas connection between the ignition valve and the pilot burner for soundness with a soap solution or other approved method and seal any leakages. Switch off the electrical supply and check that the burner has extinguished. Remove the pressure gauge from the burner manifold and tighten the pressure test screw on the gas valve.
10. Check the reliability of ignition of the boiler by switching the boiler off using the burner on/off switch on the boiler control panel. After two minutes turn the switch back on. The boiler will now relight. Check that the pilot has a stable flame and that the main burners light smoothly.
11. With the boiler switched on test for soundness on the union which is between the gas train valve and the burner manifold with a soap solution or other approved method and seal any leaks.
12. Turn the appliance isolation valve off. The main and pilot burners should go off. The boiler will attempt to relight. Check that the ignitor starts and that the boiler locks out.

SETTING THE GAS VALVE (5 to 11 Section)

High Fire Setting

1. Start the burner with the two thermostats at maximum. The boiler should warm up for a minimum of 20 minutes before starting setting procedure.
2. The high fire setting has to be done first by turning the setting screw (A) of the gas valve governor. Turn to the right for more pressure or left for less pressure on the burner manifold.
3. Set the high fire pressure to 16.5 mbar.

Reduced Rate Setting

1. Reduce the setting of the high/low thermostat to minimum so that the boiler goes to low fire.
2. Unlock the screw (B) on the solenoid valve head and turn to the low rate setting ring (C), turn clockwise for less pressure and anti-clockwise for more pressure on the burner manifold.
3. Set the low fire pressure to 10.6 mbar.

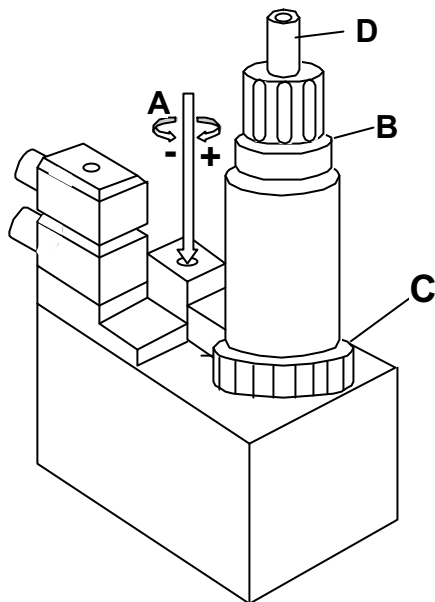
Fig.27 – Dungs MB-ZRDLE

- A- Setting Screw of Governor
B- Locking Screw
C- Low Fire Adjustment Ring
D- Adjustment Cap

SETTING THE GAS VALVE (12 TO 22 SECTION)**High Fire Setting**

1. Start the burner with the two thermostats at maximum, the boiler should warm up for a minimum of 20 minutes before starting setting procedure.
2. The high fire setting has to be done first by turning the setting screw behind the protecting head of the governor (I), turn clockwise for more pressure or anti-clockwise for less pressure on the burner manifold.
3. Set the high fire pressure to 16.5 mbar.

Reduced Rate Setting

1. Reduce the setting of the high/low thermostat to minimum so that the boiler goes to low fire.
2. Unlock the screw (M) on the solenoid valve head (B) and turn to the low rate setting ring (N), turn clockwise for less pressure and anti-clockwise for more pressure on the burner manifold.
3. Set the low fire pressure to 10.6 mbar.

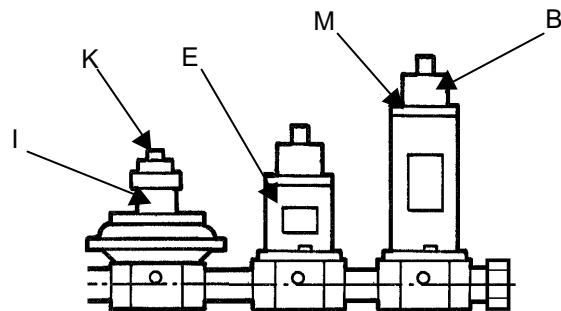
Fig.28 – Gas Train (12 – 22 Section Boilers)

- I - Governor
K - Setting Screw (Protecting Head)
E - Security Valve
M - Locking Screw
N - Low Rate Ring
B - Solenoid Valve High/Low

Ionisation Current Check

Switch the boiler off at its on/off switch and at the main isolator. Connect a micrometer into the ionisation cable in between the electrode and the cable. Switch on the main isolator and the burner on/off switch and after 15 seconds the ignition spark should be heard followed by lighting of the pilot burner. The micrometer should read approximately $7\mu\text{A}$, at start up without main burner running.

Switch off the main isolator and the on/off switch, and remove the micrometer connections.

Flue Spillage Test

With the boiler hot and cold check for spillage of combustion products with a smoke bomb or smoke wand. Check that the air is in the draught diverter and that combustion products are not spilling out of the draught diverter. The flue draught should be checked with a draught gauge and a draught of 1mm.w.g. is required and should be measured at a suitable test point in the flue above the flue adaptor socket.

DERWENT PRESTIGE

Ventilation Checks

For boiler houses with natural ventilation, the area of the grilles should be checked against the figures given for ventilation on page 2 & 3 or BS6644.

For boiler houses with mechanical ventilation, the suitability of the ventilation and extract system should be checked against the sizes given for mechanical ventilation on page 2 & 3 or BS6644

In addition, the installer should check that it is not possible for the boiler to operate if either the ventilation or extract fans are not running.

THE BOILER SHOULD NOT BE OPERATED WITHOUT ADEQUATE VENTILATION.

OPERATION OF ANCILLARY CONTROLS

After lighting the boiler, the operation of the above mentioned controls, e.g. clock and thermostats, should be checked.

TO LIGHT BOILER – NORMAL OPERATION

1. Check that the pilot gas cock and the service gas cock at the meter are on.
2. Check that all ancillary controls, e.g. time clocks are turned on.
3. Check that the electricity supply is turned on.
4. Switch on the on/off switch.
5. Check that the control panel lockout lamp is not lit, and if so, reset by pressing reset button.
6. Turn the boiler thermostat to the required setting.
7. The boiler will now light.

WARNING: If the pilot burner fails to establish or the boiler closed down after it has established, or, if the boiler closes down after the main flame has been established, no attempt should be made to relight the boiler for a period of one minute.

TO SHUT DOWN BOILER

1. Temporarily – Switch the on/off switch to “OFF”. Switch off the electrical supply.
2. Long Periods - As above but in addition turn off the service cock at the gas meter.

SETTING THE FLOW TEMPERATURE

The required flow setting should be set by the control thermostat. The temperatures that correspond to the positions on this scale are given in Fig.29. The boiler thermometer should be used to check and adjust the setting as necessary.

NOTE: The high/low operation works with two thermostats. Low fire should be adjusted at a temperature between 0°C & 5°C below the high fire temperature.

Fig 29 – Control & High/Low Thermostats

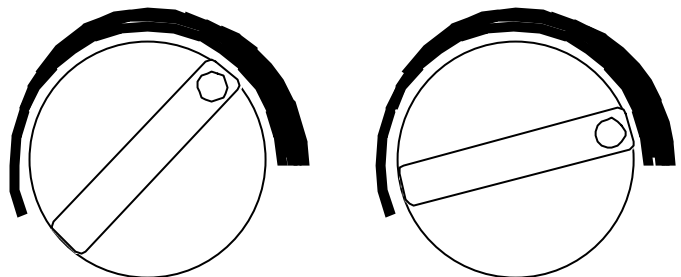

High/Low Thermostat

Control Thermostat

WATER FLOW SWITCH

For boilers fitted with a water flow switch, the installer should check that it is not possible for the boiler to fire when there is no water flow. This may be done by checking the boiler closes down when the pumps are switched off or the water flow is gated off. Always restore the water flow before completing commissioning.

BOILER MAINTENANCE

It is essential for efficient and trouble free operation that the boiler plant is regularly maintained. This must be carried out by qualified and experienced engineers and in the case of gas fired appliances attention is drawn to the mandatory requirement of CORGI (Council of Registered Gas Installers) registration of personnel undertaking work on these appliances. This facility is available from Potterton Commercial, details are available from the service offices listed on the back page of this manual.

Boilers should be serviced and re-commissioned as a minimum on an annual basis but frequency may depend on usage and application of the boiler.

It is strongly advised that a maintenance contract be entered into with Potterton Commercial Division to ensure that the boiler/burner unit is correctly and properly maintained.

WARNING Isolate the electrical and gas supplies before attempting any maintenance work.

Following completion of maintenance on the boiler, the boiler should be re-commissioned as detailed below.

BOILER CLEANING

At every service visit, the boiler should be cleaned as detailed below and the soundness of the gas control assembly must be checked. The boiler should be fully re-commissioned as described below with attention also paid to;

1. The effectiveness of natural and mechanical ventilation and in particular the safe operation of an air flow switch on a mechanical ventilation system.
2. That the chimney system is sound and adequately evacuating the products of combustion and that there is no spillage of flue products.
3. That the burner gas pressure is correct and that the boiler is still on rate.
4. That the low pressure switch on the boiler, if fitted, is operating correctly.
5. That the water flow switch, if fitted, is operating correctly.

To clean the boiler it will be necessary to remove the boiler flue hood cover and burner assembly as detailed below. **Ensure boiler is isolated from all supplies.**

1. Remove the boiler door by lifting forwards and upwards (disconnect earth wiring and chain).
2. Remove side front panel bottom fixing screws then lift upwards and forwards.
3. Remove the pilot gas pipe on the 90° elbow close to the union nut, support the gas train and undo the gas union on the burner manifold.
4. Unscrew the nuts on the burner mounting plate on right and left hand sides of the mounting plate.
5. Disconnect the spark ionisation and earth wires to the pilot burner.
6. Pull the burner assembly forward and clean the burner, pilot burner, and combustion chamber of dust and debris.

7. Clean the burner bars and ensure that the holes/slots are clear. If necessary blow the slots and internals clear with compressed air or soft brush and vacuum. On no account should the burners be wire brushed.
8. Remove the boiler top panel by loosening the rear locking plate and pushing the panel towards the back.
9. Remove the top insulation and unscrew the flue box top cover for access to the heat exchanger.
10. With the flue brushes provided clean the flueways of the cast iron heat exchanger if necessary. The burner must be removed before cleaning.

Following completion remove the debris from the bottom of the boiler and clean around the boiler.

11. Following completion of the above, the boiler should be reassembled. The integrity of the gaskets and insulation should be checked and replaced if necessary during reassembly.
12. After reassembly test for gas soundness as detailed under commissioning and check the burner manifold union and pilot burner union for gas leaks.

FAULT FINDING

Set out below are general guidance notes on system fault finding.

Overheat Operation

Operation of the boiler overheat thermostat is associated with a reduction in boiler water flow. Where overheat operation is reported the following should be checked.

- a) The boiler/system pump has not tripped.
- b) Pump overrun is operational to dissipate residual heat from the boiler on system shut down.
- c) System valves are open.
- d) The boiler is operating at the correct rate and is not overfired.

To reset the overheat thermostat allow the boiler to cool down, remove the overheat thermostat knob and press the reset button.

The use of a primary loop system is highly recommended to provide a constant boiler flow rate

DERWENT PRESTIGE

under all operating conditions. For further information refer to Potterton Publication technical Bulletin No.1 latest issue.

Burner Lockout

The boilers have an integral safety system to allow the safe and reliable operation of the burner. Failure of the burner to operate correctly will cause the burner control box to “lockout” and the lockout light on the boiler control panel will illuminate to indicate this.

Pushing the reset button can manually reset the lockout condition and the control box should restart its control sequence in an attempt to light the burner. If the control box will not reset or goes to lockout after being reset then the services of a boiler repair/ maintenance company should be sought. This service is available from Potterton Commercial service offices details of which can be found on the back page of this manual.

WARNING: The lockout reset button should not be repeatedly operated otherwise a hazardous situation may occur.

Should the boiler go to lockout, check the following before attempting to re-light the burner.

1. The gas meter pressure is above 17 mbar.
2. The electrical supply to the appliance is of the correct voltage and polarity.

The Derwent Prestige boiler is fitted with a Dungs DGA1 65F control box. The control box controls the safe start up of the burner in sequence. See Fault Finding table on Page 30 for details of control box lockout conditions.

<p><u>Stage 1</u></p> <p>Boiler does not attempt to light. Control Box does not lockout.</p>	<p>a) Check electricity supply is available to boiler and on/off switch is illuminated. The boiler has an integral fuse.</p> <p>b) Check the boiler is being called to operate. Thermostat calling lamp should be lit unless internal thermostat is satisfied or external control circuit is broken.</p> <p>c) Check overheat cut off device has not operated.</p> <p>d) Check power supply is available to control box (see wiring diagram). Replace box if faulty.</p>
<p><u>Stage 2</u></p> <p>No Ignition Spark. Pilot does not Light. Control Box goes to lockout</p>	<p>a) Check Ignition electrode continuity for earth fault.</p> <p>b) Check power supply is available to ignitor during ignition period.</p> <p>c) Check operation of ignitor. Replace if necessary</p>
<p><u>Stage 3</u></p> <p>Ignition sparks Pilot does not Light. Control Box goes to lockout</p>	<p>a) Check gas supply is available at the pilot burner at the correct pressure.</p> <p>b) Check gas supply is purged of air.</p> <p>c) Check pilot injector</p> <p>d) Check ignition electrode position.</p>
<p><u>Stage 4</u></p> <p>Pilot Burner lights Control Box goes to lockout safety time</p>	<p>a) Check electrical supply polarity</p> <p>b) Check earth continuity to pilot burner</p> <p>c) Check pilot burner pressure is correct</p> <p>d) Check there is no earth leakage on ionisation probe circuit.</p> <p>e) Check ionisation probe circuit for correct flame current. This is achieved by connecting a DC micrometer in series. A reading of at least 7μA DC should be obtained. If this is obtained and the control box continues to lock out then replace the control box.</p>
<p><u>Stage 5</u></p> <p>Pilot Burner Lights. Main burner does not light Control Box does not lockout</p>	<p>a) Check main burner gas cock is open.</p> <p>b) Check electrical continuity to main gas valve</p> <p>c) Check operation of gas valve and replace if necessary</p> <p>d) Check control box. Replace if necessary</p>
<p><u>Stage 6</u></p> <p>Pilot Burner Lights Main burner lights Control box locks out.</p>	<p>a) Check ignition of main flame is smooth and reliable.</p> <p>b) Check voltage supply for interference.</p> <p>c) Faulty Control Box</p>

DERWENT PRESTIGE

COMPONENT REPLACEMENT

Before commencing any component replacement, isolate the electrical and gas supplies to the boiler. After every service visit the soundness of the gas control assembly must be checked as described on page 31.

Main Burner Bar

1. Remove the main burner assembly as described under "Cleaning the Boiler" on page 28.
2. Refitting the burner assembly is the reverse of the above procedure.

Pilot Burner & Electrodes

1. Release the pilot burner by unscrewing the union on the rear of the pilot burner then undoing the two screws securing the pilot burner to the burner mounting plate.(when removing the pilot burner take care not to loose the pilot injector)
2. Release the electrodes and fit new electrodes if necessary.
3. Fit the pilot burner and check the electrode position as shown in Fig. 25, page 21.

High Limit, Control & High/Low Thermostat

1. Remove the two screws securing the control panel front fascia and hinge it down.
2. Release the quick release connection on the door by firmly pressing in and turn it one quarter turn to the left to open the door.
3. Remove the chain and earth wires and lift the door off.
4. Remove the thermostat phial from the thermostat pocket and thread it through the grommet into the control panel.
5. Remove the electrical connections to the thermostat, which are made by push on female connectors.
6. Remove the nut securing the thermostat to the control panel fascia. For the control & high/low thermostats the nut is located beneath the thermostat knob and for the limit thermostat it is located beneath the cover.
7. Fitting the new thermostat is the reversal of the above procedure. The thermostat phial should be positioned as shown in Fig.24, page 20.

Thermometer

1. Remove the two screws securing the control panel front fascia and hinge it down.
2. Release the quick release connection on the door by firmly pressing in and turn it one quarter turn to the left to open the door.
3. Remove the chain and earth wires and lift the door off.
4. Remove the thermometer phial from the thermometer pocket and thread it through the grommet into the control panel.
5. Push the thermometer from the inside to the outside by pressing the two clamps.
6. Fit the new thermometer as the reversal of the above procedure. The thermometer phial should be positioned as shown in Fig.24, page 20.

Control Box

1. Remove the two screws securing the control panel fascia and hinge it down.
2. Remove the two screws securing the control box base and then remove the control box.
3. Disconnect the wiring connections.
4. If the control box only is to be replaced fit the new box as a reverse of the above procedure.
5. Replace the wiring in the same order.

Spark Generator

1. Release the quick release connection on the door by firmly pressing in and turn it one quarter turn to the left to open the door.
2. Remove the chain and earth wires and lift the door off.
3. Disconnect the spark generator connections from the control box base.
4. Remove the four screws securing the ignitor to the front panel.
5. Replace the spark generator as a reversal of the above procedure.
6. Recommission the boiler as described on page 23 to check the operation of the control box.

Main Gas Line Components

1. Release the quick release connection on the door by firmly pressing in and turn it one quarter turn to the left to open the door.
2. Remove the chain and earth wires and lift the door off.
3. Unplug the electrical connection to the gas train.
4. Release the burner manifold union and the pilot line connection to the pilot burner.
5. Disconnect the gas train rear union upstream and lift away the gas train complete.
6. Remove the cover plates and disconnect the electrical connections to the valve if necessary.
7. Change the valves or governor as necessary.
8. Remake the electrical connections and replace the pilot line and main gas line.
9. After replacing the complete gas train check for gas soundness as described on page below.

TO TEST FOR GAS SOUNDNESS OF CONTROL ASSEMBLY & SAFETY SHUT OFF VALVES.

To be read in conjunction with the schematic gas diagram (Fig.30). IN ADDITION TO THE SPECIFIC VALVE PROVING TESTS BELOW ALL GAS JOINTS SHOULD BE CHECKED FOR LEAKS WITH A SOAP SOLUTION, (including the gas line to the pilot burner and main gas burner manifold).

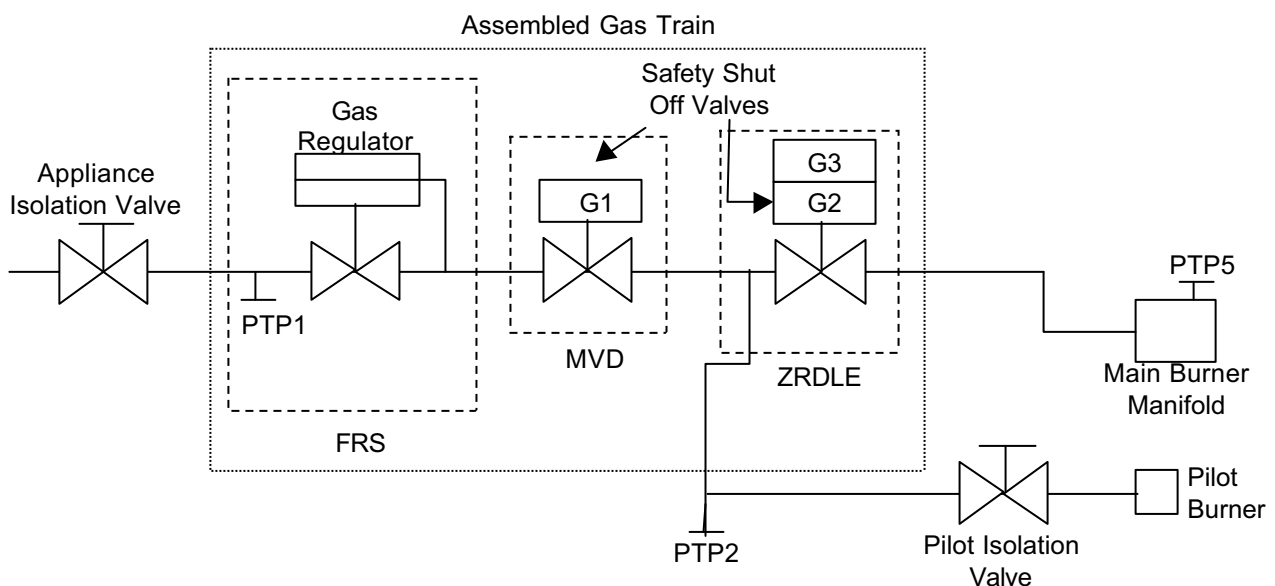
Fig 30 – Gas Train Configuration**1st Safety Shut Off Valve Gas Soundness**

Fit a pressure gauge to PTP1. Open the appliance isolation valve. Once a gauge pressure is observed close the appliance isolation valve. Observe the pressure gauge for 2 minutes. THERE SHOULD BE NO DROP IN GAUGE PRESSURE.

If a drop in gauge pressure is observed check for leaks with a soap solution or other approved method. If no external leaks are detected the 1st Safety Shut Off Valve (G1) is passing gas and should be replaced.

2nd Safety Shut Off Valve Gas Soundness

Fit a pressure gauge to PTP2, ensure that the gauge pressure is zero. Close the pilot isolation valve. Open the appliance isolation valve and start the boiler, the pressure should rise to line pressure and stay stable. Observe the pressure gauge for 2 minutes. Close the appliance isolating valve.

If a fall in gauge pressure is observed then the 2nd Safety Shut Off Valve (G2) is passing gas and should be replaced.

Once the soundness test has been successfully completed tighten the pressure test points and check for leaks with soap solution or other approved method.

DERWENT PRESTIGE

Fig 31 – Pump Overrun Using Changeover Pipe Thermostat

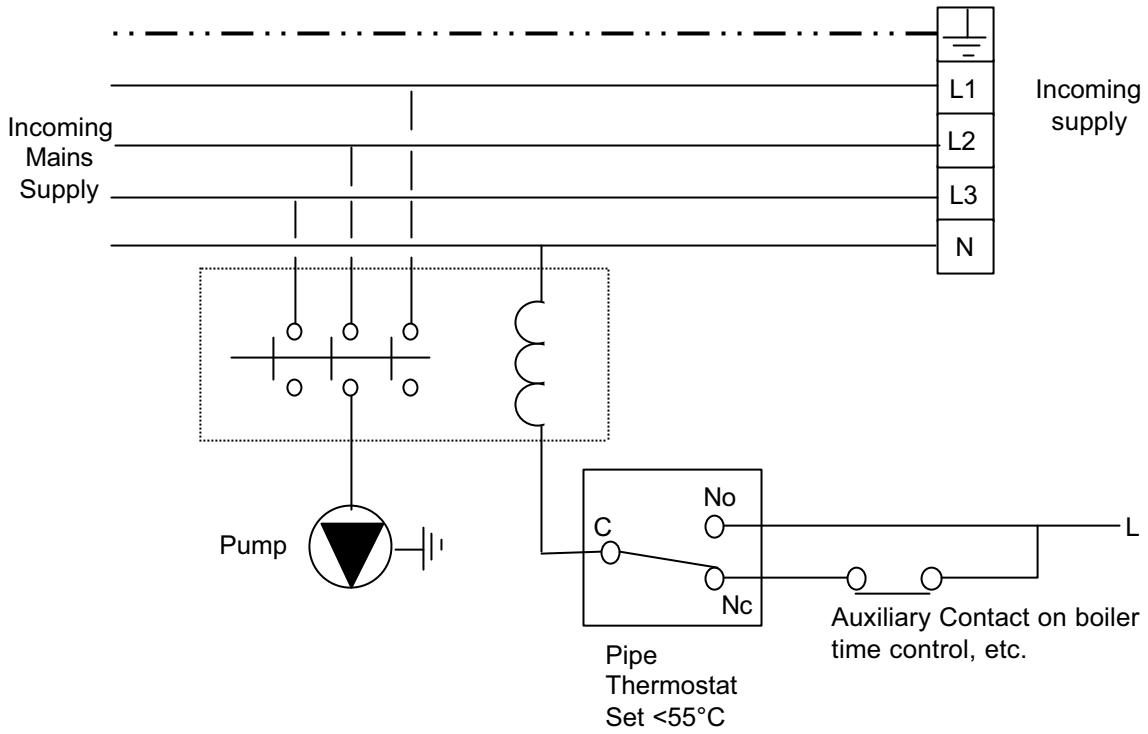
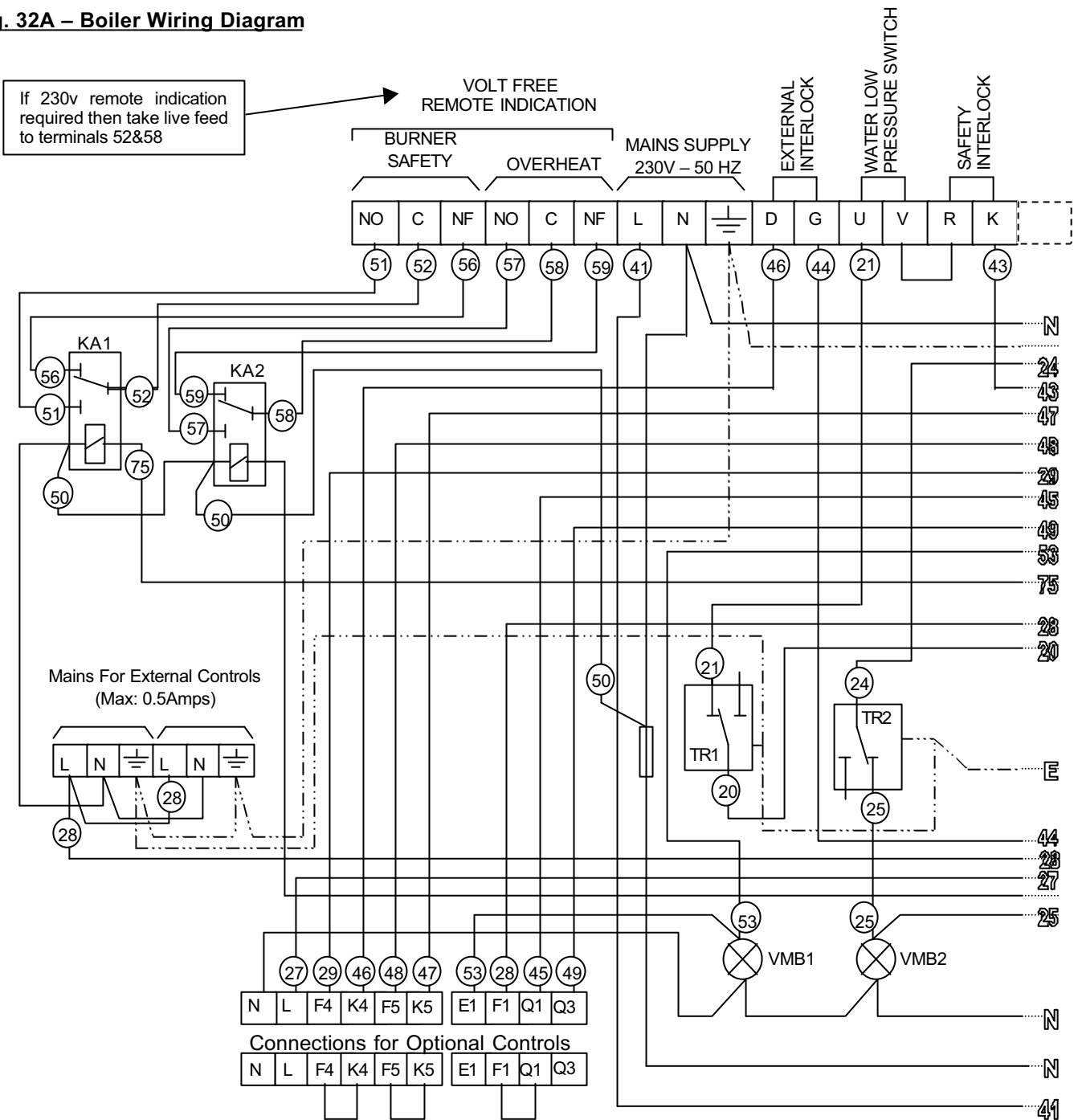
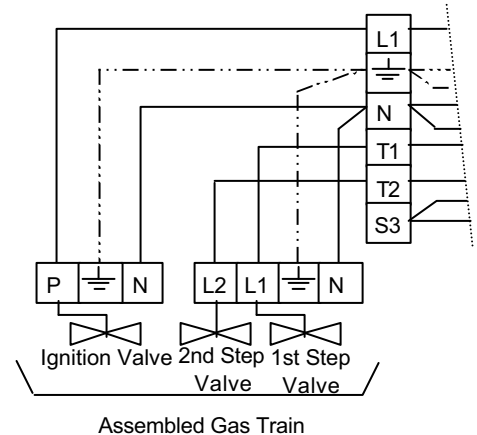

Fig. 32A – Boiler Wiring Diagram



LEGEND

- VMB1 - 1st Stage Indicator Light, flame indicator light
- VMB2 - 2nd Stage Indicator Light
- VSB - Flame failure Indicator Light
- VSC - Overheat Indicator Light
- MST - Mains Indicator Light
- TR1 - 1st Stage thermostat
- TR2 - 2nd Stage Thermostat
- STB - Overheat Thermostat
- TTB - Flue Safety Device (5,6, and 7 only)
- ZT - Test Switch
- ZP - Pump Switch
- ZB - Burner Switch
- ZRB - Burner Re-set after Flame Failure
- F1 - Fuse (6.3A AT)
- KA1 - Relay for Remote Indication – Overheat
- KA2 - Relay for Remote Indication – Burner Flame Failure
- P - Gas Low Pressure Switch



DERWENT PRESTIGE

Fig.32B – WIRING DIAGRAM

See Page 34 Legend

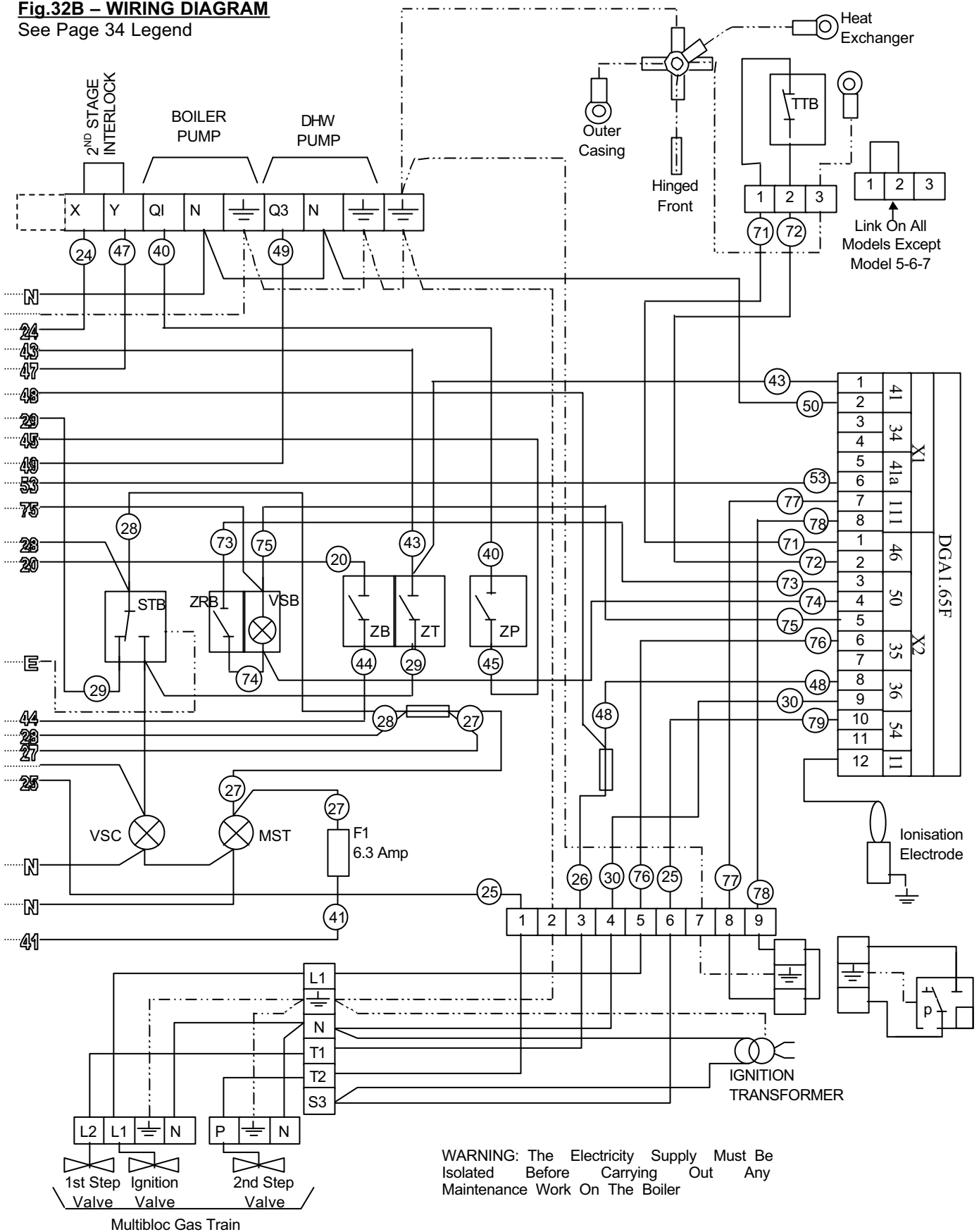
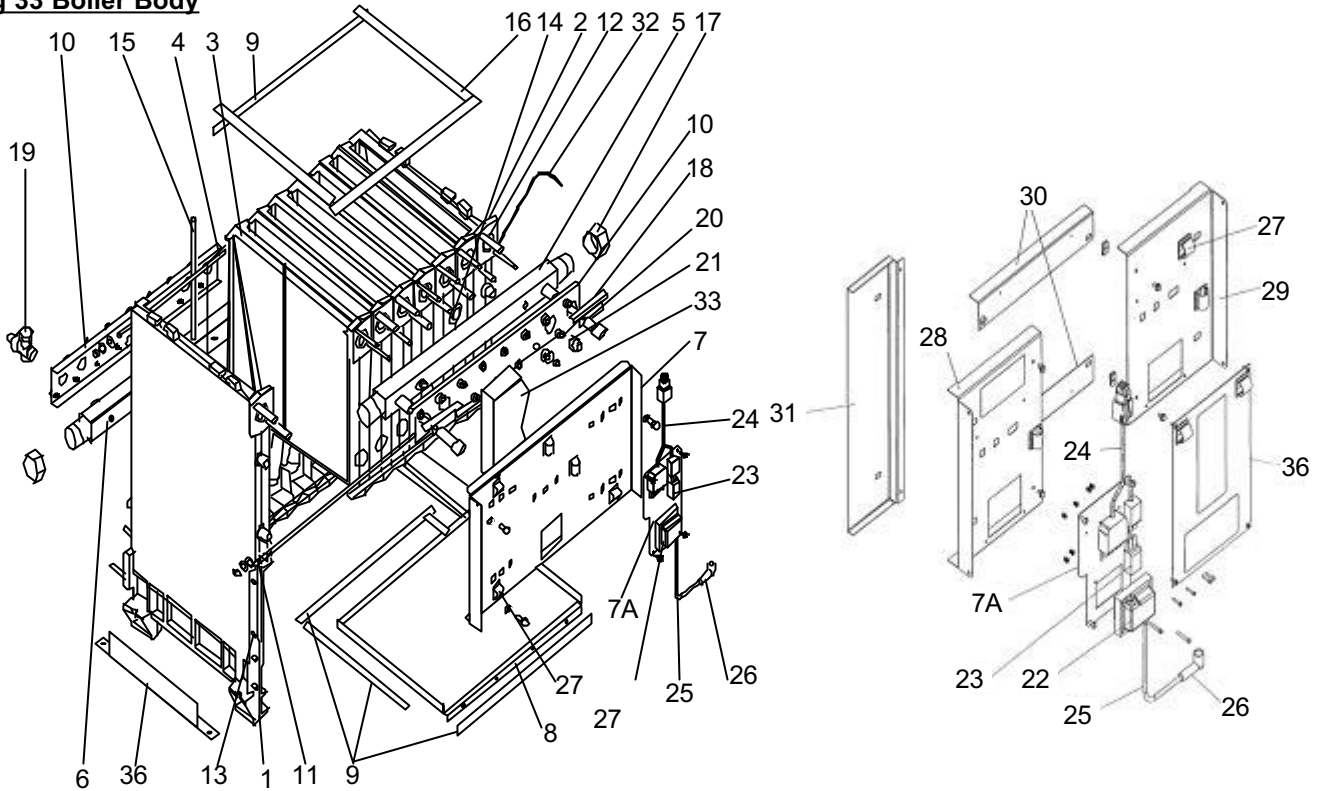

Fig 33 Boiler Body



Item No.	Description	Quantity Per Boiler	Part No.
1	Left Hand End Section	1	COM17800856
2	Right Hand End Section	1	COM17800846
3	Intermediate Section		COM17804056
4	Boiler Rear Plate 5 – 8 Section	1	COM17995634
5	Flow Header – 5 Section	1	COM17006480
	Flow Header – 6 Section	1	COM17006481
	Flow Header – 7 Section	1	COM17006482
	Flow Header – 8 Section	1	COMN9270030
	Flow Header – 9 Section	1	COMN9270040
	Flow Header – 10 Section	1	COMN9270050
	Flow Header – 11 Section	1	COMN9270060
	Flow Header – 12 Section	1	COMN9270070
	Flow Header – 13 Section	1	COMN9270080
	Flow Header – 14 Section	1	COMN9270090
	Flow Header – 15 Section	1	COMN9270100
	Flow Header – 16 Section	1	COMN9270110
	Flow Header – 17 Section	1	COMN9270120
	Flow Header – 18 Section	1	COMN9270130
	Flow Header – 20 Section	1	COMN9116340
	Flow Header – 22 Section	1	COMN9116350
6	Return Header – 5 Section	1	COM17006483
	Return Header – 6 Section	1	COM17006484
	Return Header – 7 Section	1	COM17006485
	Return Header – 8 Section	1	COMN9270190
	Return Header – 9 Section	1	COMN9270200
	Return Header – 10 Section	1	COMN9270210
	Return Header – 11 Section	1	COMN9270220
	Return Header – 12 Section	1	COMN9270230

Item No.	Description	Quantity Per Boiler	Part No.
11	Tie Bar (M10) – 18 Section	3	COMN9171290
	Tie Bar (M10) – 20 Section	3	COMN9171470
	Tie Bar (M10) – 22 Section	3	COMN9171480
12	Fixing Stud – M10 x 80		COMN9171140
13	Fixing Stud – M8 x 20		COMN9171150
14	Sealing Ring (Rubber)		COMN9195220
15	Ceramic Sealing Strip 14m		COMN9195370
16	Ceramic Felt Strips	1	COMN9205350
17	Blanking Cap (5 – 16 Section)	22	COMN9125170
18	Case Support Bracket (9 – 22 Section)	1	COMN9100994
19	¾" Drain Cock	1	COMN9010050
20	Thermostat Pocket	1	COMN9115030
21	½" BSP Plug	1	COMN9125010
22	Ignition Transformer	1	COM17007160
23	Connector (Female)	1	COM17071432
24	Control Panel Cable (5 – 8 Section)	1	COM17071664
	Control Panel Cable (9 – 10 Section)	1	COM17071665
	Control Panel Cable (11 – 14 Section)	1	COM17071666
	Control Panel Cable (15 – 18 Section)	1	COM17071667
	Control Panel Cable (20 – 22 Section)	1	COM17071668
25	Ignitor Lead	1	COM15825230
26	Ignition Cap	1	COMN9060420
27	Cable Support Clip	6	COM17001083
28	Left hand Front panel (9 – 22 Section)	1	COM17995679
29	Right Hand Front panel (9 – 22 Section)	1	COM17995678
30	Connector Strip (9 Section)	2	COM17991474
	Connector Strip (10 Section)	2	COM17991484
	Connector Strip (11 Section)	2	COM17991494
	Connector Strip (12 Section)	2	COM17991504
	Connector Strip (13 Section)	2	COM17991514
	Connector Strip (14 Section)	2	COM17991524
	Connector Strip (15 Section)	2	COM17991534
	Connector Strip (16 Section)	2	COM17991544
	Connector Strip (17 Section)	2	COM17991554
	Connector Strip (18 Section)	2	COM17991564
	Connector Strip (20 Section)	2	COM17991574
	Connector Strip (22 Section)	2	COM17991584
31	Boiler Rear Panel (9 – 22 Section)	1	COM17995654
32	Earth Wire	1	COM17071647
33	Boiler Front Insulation (5 – 8 Section)	1	COM
	Boiler Front Insulation (9 Section)	1	COM17070879
	Boiler Front Insulation (10 Section)	1	COM17070880
	Boiler Front Insulation (11 Section)	1	COM17070881
	Boiler Front Insulation (12 Section)	1	COM17070882
	Boiler Front Insulation (13 Section)	1	COM17070883
	Boiler Front Insulation (14 Section)	1	COM17070884
	Boiler Front Insulation (15 Section)	1	COM17070885
	Boiler Front Insulation (16 Section)	1	COM17070886
	Boiler Front Insulation (17 Section)	1	COM17070887
	Boiler Front Insulation (18 Section)	1	COM17070888
	Boiler Front Insulation (20 Section)	1	COM17070889
	Boiler Front Insulation (22 Section)	1	COM17070890

DERWENT PRESTIGE

Item No.	Description	Quantity Per Boiler	Part No.
34	Bag Of Screws (5-9 Section)	1	COM17881066
	Bag Of Screws (10-14 Section)	1	COM17881067
	Bag Of Screws (15-18 Section)	1	COM17881068
	Bag Of Screws (20-22 Section)	1	COM17881069
36	Data Plate (9 – 22 Section)	2	COM17070892

Fig 34 Burner Assembly

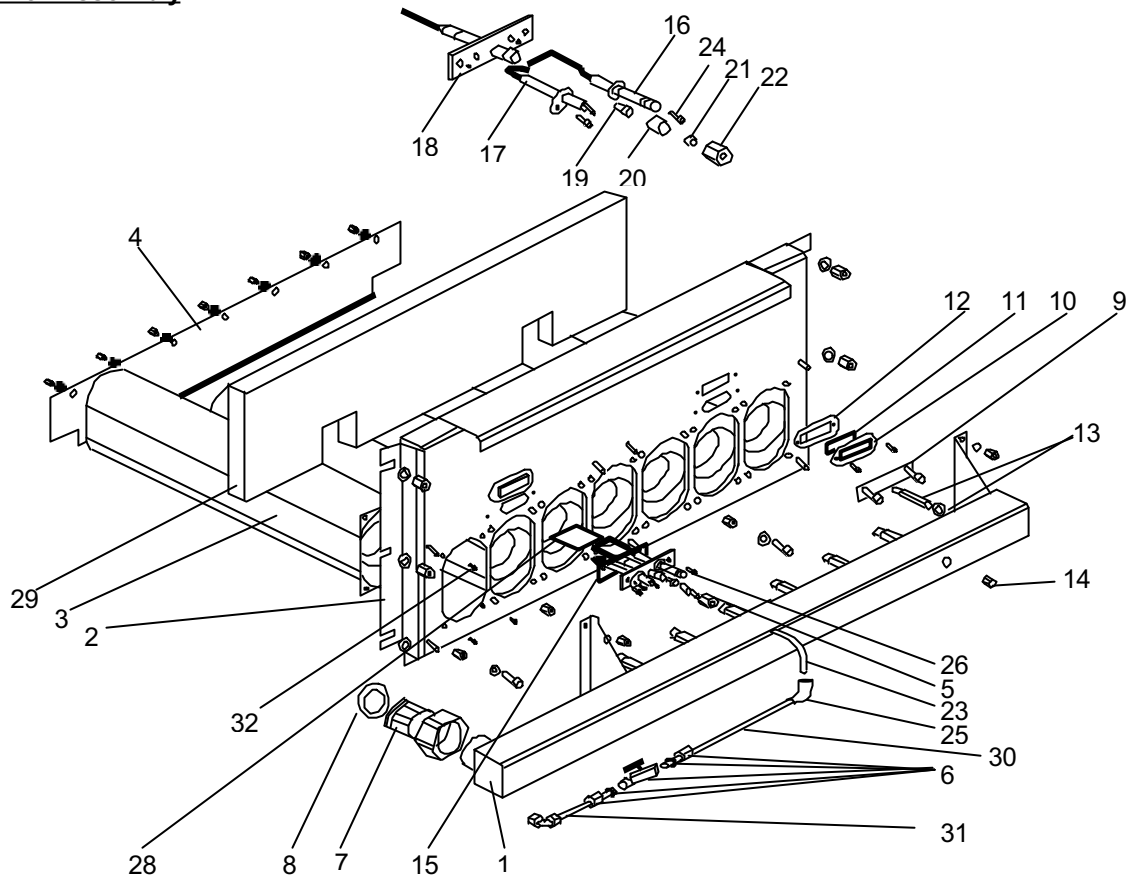

Item No.	Description	Quantity Per Boiler	Part No.
1	Gas Manifold (5 Section)	1	COM17006610
	Gas Manifold (6 Section)	1	COM17006611
	Gas Manifold (7 Section)	1	COM17006612
	Gas Manifold (8 Section)	1	COMN9116410
	Gas Manifold (9 Section)	1	COMN9116420
	Gas Manifold (10 Section)	1	COMN9116430
	Gas Manifold (11 Section)	1	COMN9116440
	Gas Manifold (12 Section)	1	COMN9116450
	Gas Manifold (13 Section)	1	COMN9116460
	Gas Manifold (14 Section)	1	COMN9116470
	Gas Manifold (15 Section)	1	COMN9116480
	Gas Manifold (16 Section)	1	COMN9116490
	Gas Manifold (17 Section)	1	COMN9116500
	Gas Manifold (18 Section)	1	COMN9116510
	Gas Manifold (20 Section)	1	COMN9116520
	Gas Manifold (22 Section)	1	COMN9116530

Item No.	Description	Quantity Per Boiler	Part No.
2	Burner Mounting Plate (5 Section)	1	COMN9253820
	Burner Mounting Plate (6 Section)	1	COMN9253830
	Burner Mounting Plate (7 Section)	1	COMN9253840
	Burner Mounting Plate (8 Section)	1	COMN9253850
	Burner Mounting Plate (9 Section)	1	COMN9253860
	Burner Mounting Plate (10 Section)	1	COMN9253870
	Burner Mounting Plate (11 Section)	1	COMN9253880
	Burner Mounting Plate (12 Section)	1	COMN9253890
	Burner Mounting Plate (13 Section)	1	COMN9253900
	Burner Mounting Plate (14 Section)	1	COMN9253910
2	Burner Mounting Plate (15 Section)	1	COMN9253920
	Burner Mounting Plate (16 Section)	1	COMN9253930
	Burner Mounting Plate (17 Section)	1	COMN9253940
	Burner Mounting Plate (18 Section)	1	COMN9253950
	Burner Mounting Plate (20 Section)	1	COMN9253960
	Burner Mounting Plate (22 Section)	1	COMN9253970
3	Burner Bar	-	COMN9020400
4	Burner Back Plate (5 Section)	1	COMN9253984
	Burner Back Plate (6 Section)	1	COMN9253994
	Burner Back Plate (7 Section)	1	COMN9254004
	Burner Back Plate (8 Section)	1	COMN9254014
	Burner Back Plate (9 Section)	1	COMN9254024
	Burner Back Plate (10 Section)	1	COMN9254034
	Burner Back Plate (11 Section)	1	COMN9254044
	Burner Back Plate (12 Section)	1	COMN9254054
	Burner Back Plate (13 Section)	1	COMN9254064
	Burner Back Plate (14 Section)	1	COMN9254074
	Burner Back Plate (15 Section)	1	COMN9254084
	Burner Back Plate (16 Section)	1	COMN9254094
	Burner Back Plate (17 Section)	1	COMN9254104
	Burner Back Plate (18 Section)	1	COMN9254114
	Burner Back Plate (20 Section)	1	COMN9254124
	Burner Back Plate (22 Section)	1	COMN9254134
5	Pilot Assembly	1	COM17077800
6	Pilot Isolating Valve Assembly	1	COM17006475
7	Union (5 – 11 Section)	1	COM15929069
	Union (12 – 22 section)	1	COM
8	Gas Seal (5 – 11 Section)	1	COM15600310
	Gas Seal (12 – 22 Section)	1	COMN9195590
9	Pilot Blanking Plate (8 – 22 Section)	1	COMN9083824
10	Sight Glass Assembly	1	COMN9022010
11			
12			
13	Main Injector & Washer (3.2mm)		COM17403992
14	Pressure Test Point	1	COM17006203
15	Pilot Mounting Plate	1	COM17002110
16	Ionisation Electrode	1	COMN9051800
17	Ignition Electrode	1	COMN9051770
18	Pilot	1	COM12002777
19	Pilot Injector	1	COMN5590360
20	Pilot Filter	1	COM17003234
21	Olive	1	COM
22	Nut	1	COM
23	Pilot Supply Elbow (6mm Aluminium)	1	COMN9105010

DERWENT PRESTIGE

Item No.	Description	Quantity Per Boiler	Part No.
24	Ignition Electrode Securing Screw	1	COM15197083
25	Elbow	2	COMN9120070
	Nuts	2	COMN9120280
	Olives	2	COMN9120270
26	Earth Connector	1	COMN9063030
28	Pilot Shield	1	COMN9095480
29	Door Insulation (5 – Section)	1	COM17070792
	Door Insulation (6 – Section)	1	COM17070793
	Door Insulation (7 – Section)	1	COM17070794
	Door Insulation (8 – Section)	1	COM17070795
	Door Insulation (9 – Section)	1	COM17070796
	Door Insulation (10 – Section)	1	COM17070797

Item No.	Description	Quantity Per Boiler	Part No.
29	Door Insulation (11 – Section)	1	COM17070798
	Door Insulation (12 – Section)	1	COM17070799
	Door Insulation (13 – Section)	1	COM17070800
	Door Insulation (14 – Section)	1	COM17070801
	Door Insulation (15 – Section)	1	COM17070802
	Door Insulation (16 – Section)	1	COM17070803
	Door Insulation (17 – Section)	1	COM17070804
	Door Insulation (18 – Section)	1	COM17070805
	Door Insulation (20 – Section)	1	COM17070806
	Door Insulation (22 – Section)	1	COM17070807
30	Pilot Tube	1	COM17077795
31	Pilot Tube	1	COM17077797
32	Burner Securing Screw	1	COM15969356
33	Bag of Screws (5 – 12 Section)	1	COM17881078
	Bag of Screws (13 – 22 Section)	1	COM17881079

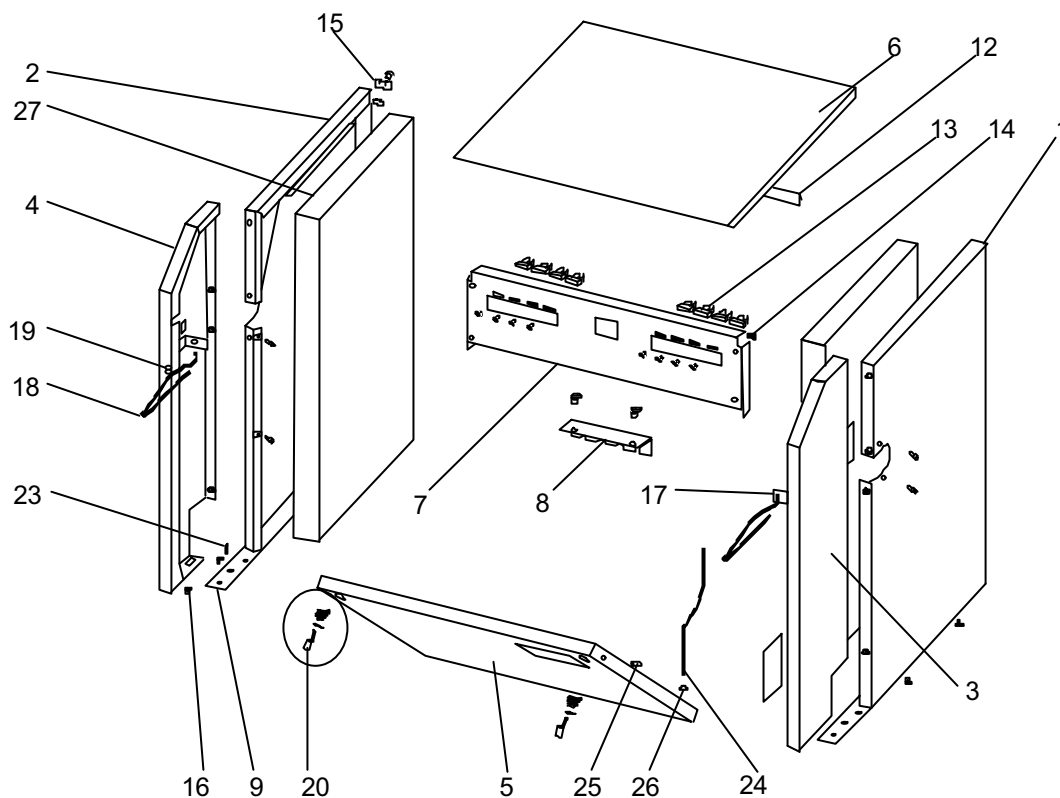
Fig 35 Casing Assembly

Item No.	Description	Quantity Per Boiler	Part No.
1	Rear Side Panel Right Hand	1	COM17992399
2	Rear Side Panel Left Hand	1	COM17992469
3	Front Side Panel Right Hand	1	COM17990398
4	Front Side Panel Left Hand	1	COM17990408
5	Door (5 – 8 Section)	1	COM17990269
	Door (9 Section)	1	COM17990279
	Door (10 Section)	1	COM17990289
	Door (11 Section)	1	COM17990299

DERWENT PRESTIGE

Item No.	Description	Quantity Per Boiler	Part No.
	Door (12 Section)	1	COM17990309
	Door (13 Section)	1	COM17990319
	Door (14 Section)	1	COM17990329
	Door (15 Section)	1	COM17990339
	Door (16 Section)	1	COM17990349
	Door (17 Section)	1	COM17990359
	Door (18 Section)	1	COM17990369
	Door (20 Section)	1	COM17990379
	Door (22 Section)	1	COM17990389
6.	Top Panel (5 – 8 Section)	1	COM17990456
	Top Panel (9 Section)	1	COM17990466
	Top Panel (10 Section)	1	COM17990476
	Top Panel (11 Section)	1	COM17990486
	Top Panel (12 Section)	1	COM17990496
	Top Panel (13 Section)	1	COM17990506
	Top Panel (14 Section)	1	COM17990516
	Top Panel (15 Section)	1	COM17990526
	Top Panel (16 Section)	1	COM17990536
	Top Panel (17 Section)	1	COM17990546
	Top Panel (18 Section)	1	COM17990556
6	Top Panel (20 Section)	1	COM17990566
	Top Panel (22 Section)	1	COM17990576
7	Control Panel Support (5 – 8 Section)	1	COM17990654
	Control Panel Support (9 Section)	1	COM17990664
	Control Panel Support (10 Section)	1	COM17990674
	Control Panel Support (11 Section)	1	COM17990684
	Control Panel Support (12 Section)	1	COM17990694
	Control Panel Support (13 Section)	1	COM17990704
	Control Panel Support (14 Section)	1	COM17990714
	Control Panel Support (15 Section)	1	COM17990724
	Control Panel Support (16 Section)	1	COM17990734
	Control Panel Support (17 Section)	1	COM17990744
	Control Panel Support (18 Section)	1	COM17990754
	Control Panel Support (20 Section)	1	COM17990764
	Control Panel Support (22 Section)	1	COM17990774
8	Control Panel Bracket (5 – 8 Section)	1	COM17995624
9	Side Panel Bottom Support Rail	2	COM17002580
12	Top panel Support Rail (5 – 8 Section)	1	COM17991344
	Top Panel Support Rail (9 Section)	1	COM17991354
	Top Panel Support Rail (10 Section)	1	COM17991364
	Top Panel Support Rail (11 Section)	1	COM17991374
	Top Panel Support Rail (12 Section)	1	COM17991384
	Top Panel Support Rail (13 Section)	1	COM17991394
	Top Panel Support Rail (14 Section)	1	COM17991404
	Top Panel Support Rail (15 Section)	1	COM17991414
	Top Panel Support Rail (16 Section)	1	COM17991424
	Top Panel Support Rail (17 Section)	1	COM17991434
	Top Panel Support Rail (18 Section)	1	COM17991444
	Top Panel Support Rail (20 Section)	1	COM17991454
	Top Panel Support Rail (22 Section)	1	COM17991464
13	Cable Clamp	8	COM17076333
14	M5 Fixing		COM15237821
15	Fixing Plate	2	COM17000693
16	Door Mounting Pin	2	COM17000268

Item No.	Description	Quantity Per Boiler	Part No.
17	Door Fastening Bracket	2	COM17990586
18	Door Restraining Chain	2	COM17007017
19	Quick Release – Locking Plate	2	COM17002478
20	Door Fixing Pack		COM17880409
21			
22			
23	8mm Dia Pin	2	COM15199249
24	Earth Cable (Heat Exchanger to Door)	1	COM17071662
25	Plastic Rivet	2	COM15237980
26	Cable Connection	1	COM15237445
27	Side Insulation Panel (9 – 22 Section)	2	COM17070878
28	Pack of Screws (not shown)	1	COM17881101

Fig 36 Flue Box

5 - 7 Section

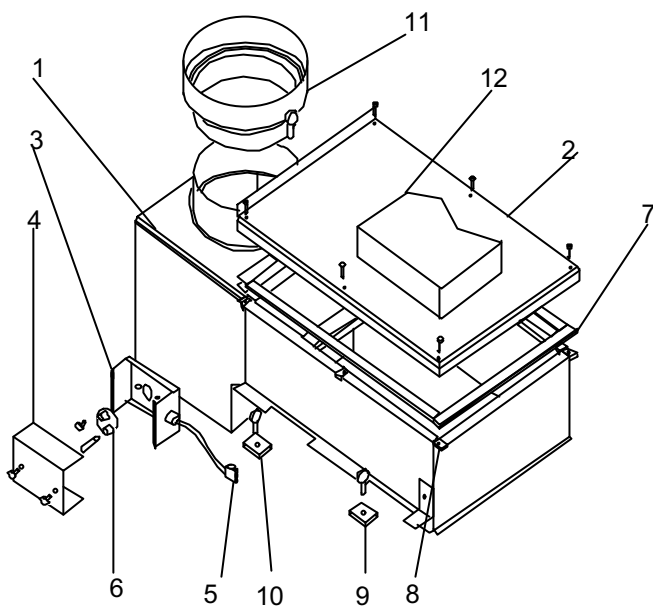

8 - 22 Section

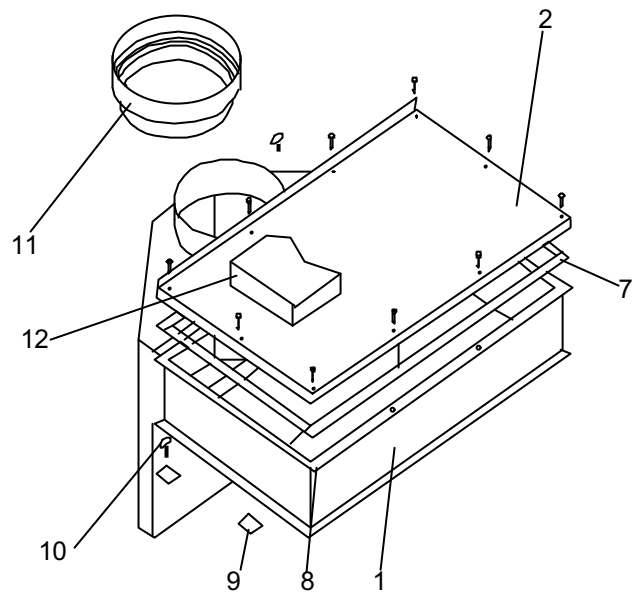

Item No.	Description	Quantity Per Boiler	Part No.
1	Flue Box (5 Section)	1	COMN7462140
	Flue Box (6 Section)	1	COMN7462150
	Flue Box (7 Section)	1	COMN7462160
	Flue Box (8 Section)	1	COMN7462170
	Flue Box (9 Section)	1	COMN7462180
	Flue Box (10 Section)	1	COMN7462190
	Flue Box (11 Section)	1	COMN7462200
	Flue Box (12 Section)	1	COMN7462210
	Flue Box (13 Section)	1	COMN7462220
	Flue Box (14 Section)	1	COMN7462230
	Flue Box (15 Section)	1	COMN7462240
	Flue Box (16 Section)	1	COMN7462250
	Flue Box (17 Section)	1	COMN7462260
	Flue Box (18 Section)	1	COMN7462270
	Flue Box (20 Section)	1	COMN7462280
	Flue Box (22 Section)	1	COMN7462290
2	Flue Box Top Cover (5 Section)	1	COMN9078944

DERWENT PRESTIGE

Item No.	Description	Quantity Per Boiler	Part No.
	Flue Box Top Cover (6 Section)	1	COMN9078954
	Flue Box Top Cover (7 Section)	1	COMN9078964
	Flue Box Top Cover (8 Section)	1	COMN9078974
	Flue Box Top Cover (9 Section)	1	COMN9078984
	Flue Box Top Cover (10 Section)	1	COMN9078994
	Flue Box Top Cover (11 Section)	1	COMN9079004
	Flue Box Top Cover (12 Section)	1	COMN9079014
	Flue Box Top Cover (13 Section)	1	COMN9079024
	Flue Box Top Cover (14 Section)	1	COMN9079034
	Flue Box Top Cover (15 Section)	1	COMN9079044
	Flue Box Top Cover (16 Section)	1	COMN9079054
	Flue Box Top Cover (17 Section)	1	COMN9079064
	Flue Box Top Cover (18 Section)	1	COMN9079074
	Flue Box Top Cover (20 Section)	1	COMN9079084
	Flue Box Top Cover (22 Section)	1	COMN9079094
3	Base For Flue Spillage Stat (5 –7 Section)	1	COMN7461890
4	Cover For Flue Spillage Stat (5 – 7 Section)	1	COMN9083084
5	Flue Spillage Stat Cable (5 – 7 Section)	1	COM17071661
6	Flue Spillage Stat (5 – 7 Section)	1	COMN9005230
7	Ceramic Felt	1	COMN9205320
8	Spire Clip Nut	14	COMN9183130
9	Clamping Plate	4	COMN9180060
10	Wing Nut	5	COMN9090180
11	Flue Adaptor (5 Section)	1	COMN9094094
	Flue Adaptor (6 – 7 Section)	1	COMN9094104
	Flue Adaptor (8 – 11 Section)	1	COMN9094114
	Flue Adaptor (12 – 16 Section)	1	COMN9094124
	Flue Adaptor (17 – 18 Section)	1	COMN9094134
	Flue Adaptor (20 – 22 Section)	1	COMN9094144
12	Flue Cover Insulation (5 section)	1	17070903
	Flue Cover Insulation (6 section)	1	17070904
	Flue Cover Insulation (7 section)	1	17070905
	Flue Cover Insulation (8 section)	1	17070906
	Flue Cover Insulation (9 section)	1	17070907
	Flue Cover Insulation (10 section)	1	17070908
	Flue Cover Insulation (11section)	1	17070909
	Flue Cover Insulation (12 section)	1	17070910
	Flue Cover Insulation (13 section)	1	17070911
	Flue Cover Insulation (14 section)	1	17070912
	Flue Cover Insulation (15 section)	1	17070913
	Flue Cover Insulation (16 section)	1	17070914
	Flue Cover Insulation (17 section)	1	17070915
	Flue Cover Insulation (18section)	1	17070916
	Flue Cover Insulation (20 section)	1	17070917
	Flue Cover Insulation (22 section)	1	17070918
13	Bag of Screws (5 – 7 Section)	1	COM17881076
	Bag of Screws (8 – 22 Section)	1	COM17881077

Fig 37 Control Panel

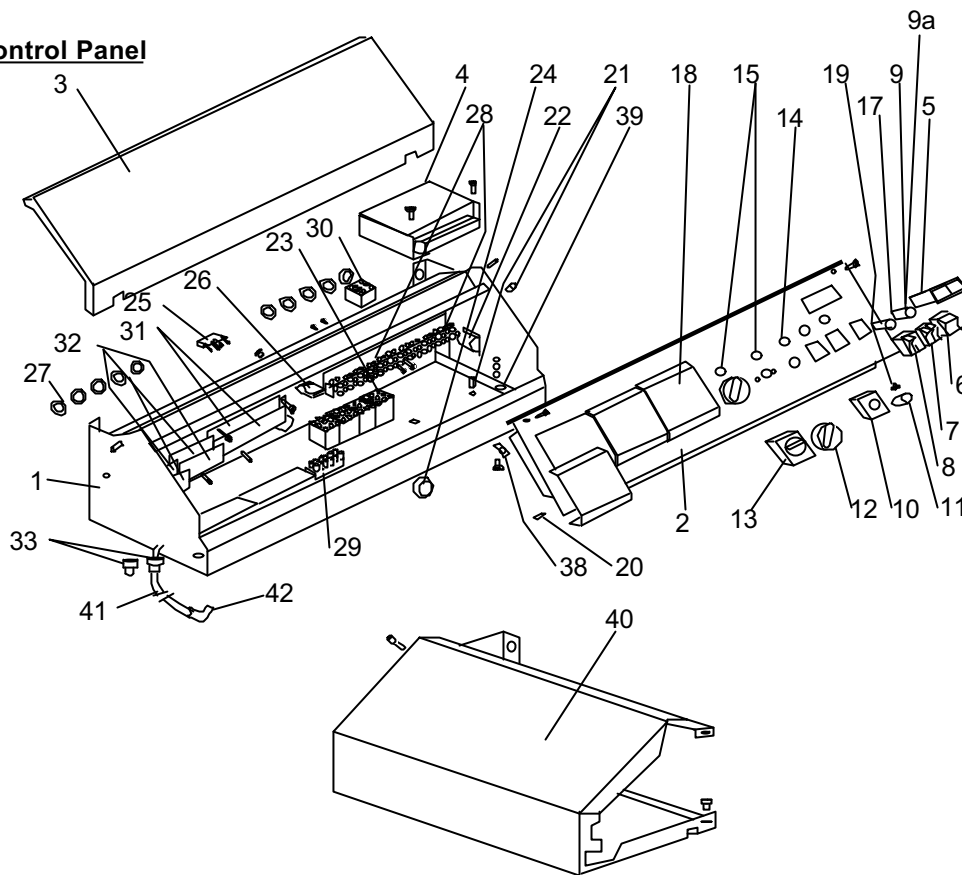

Item No.	Description	Quantity Per Boiler	Part No.
1	Control Panel Housing	1	
2	Control Panel Fascia	1	COM17990786
3	Perspex Cover	1	COM17003854
4	Control Box – Dungs DGAI.65F MOD.10.3TCL	1	COM17001084
5	Boiler Thermometer	1	COM17007061
6	Single Switch Pump	1	COM15804020
7	Double Switch (Reset & Lockout Indicator)	1	COM15804082
8	Illuminated Switch (Reset & Lockout Indicator)	1	COM158314FA
9	Fuse Housing	1	COM15803999
9a	Fuse (6.3 Amp)	1	COM15803525
10	Overheat Thermostat (with nut)	1	COM17006955
11	Overheat Thermostat Cap	1	
12	Control & High/Low Thermostat Knob	1	COM17004739
13	Thermostat (1 st stage & 2 nd stage high/low)	1	COM17007037
14	Red Neon (Overheat Indicator)	1	COM15838260
15	Green Neon (1 st stage & 2 nd stage stat)	1	COM15838262
17	Orange Neon (mains indicator)	1	COM15838261
18	Blanking Panel	3	COM17000983
19	Spacer	1	COM15237445
20	Threaded Hinge Pin C/W Screw	2	COM15238134
21	Nylon Captive Insert	4	COM15237950
22	Cable Support Clip	1	COM17001083
23	Relay (VFC for high limit & lockout)	1	COM15815049
24	Grommet	1	COM15806522
25	4 – Pin Plug – (8 – 22 Section)	1	COM17072310
26	4 – Pin Socket	1	COM17071430
27	Grommet	10	COM15806550

DERWENT PRESTIGE

Item No.	Description	Quantity Per Boiler	Part No.
28	24 – Way terminal Strip (4 x 6 Way)	2	COM15802618
29	6 – Way Terminal Strip	1	COM15802618
30	9 – Way Socket	1	COM17071431
31	Blanking Plate	1	COM17995604
32	Blanking Plate	1	COM17995614
33	Cable Gland	2	COM15814370
38	Earth Pin	1	COMN9063030
40	Extension Panel (9 Section)	1	COM17991599
	Extension Panel (10 Section)	1	COM17991609
	Extension Panel (11 Section)	1	COM17991619
	Extension Panel (12 Section)	1	COM17991629
	Extension Panel (13 Section)	1	COM17991639
	Extension Panel (14 Section)	1	COM17991649
	Extension Panel (15 Section)	1	COM17991659
	Extension Panel (16 Section)	1	COM17991669
	Extension Panel (17 Section)	1	COM17991679
	Extension Panel (18 Section)	1	COM17991689
	Extension Panel (20 Section)	1	COM17991699
	Extension Panel (22 Section)	1	COM17991709
41	Ionisation Lead	1	COM17071657
42	Ionisation Plug Cap	1	COMN9061650
43	Bag of Screws (not shown)	1	COM17881099

Fig 38 Gas Valve

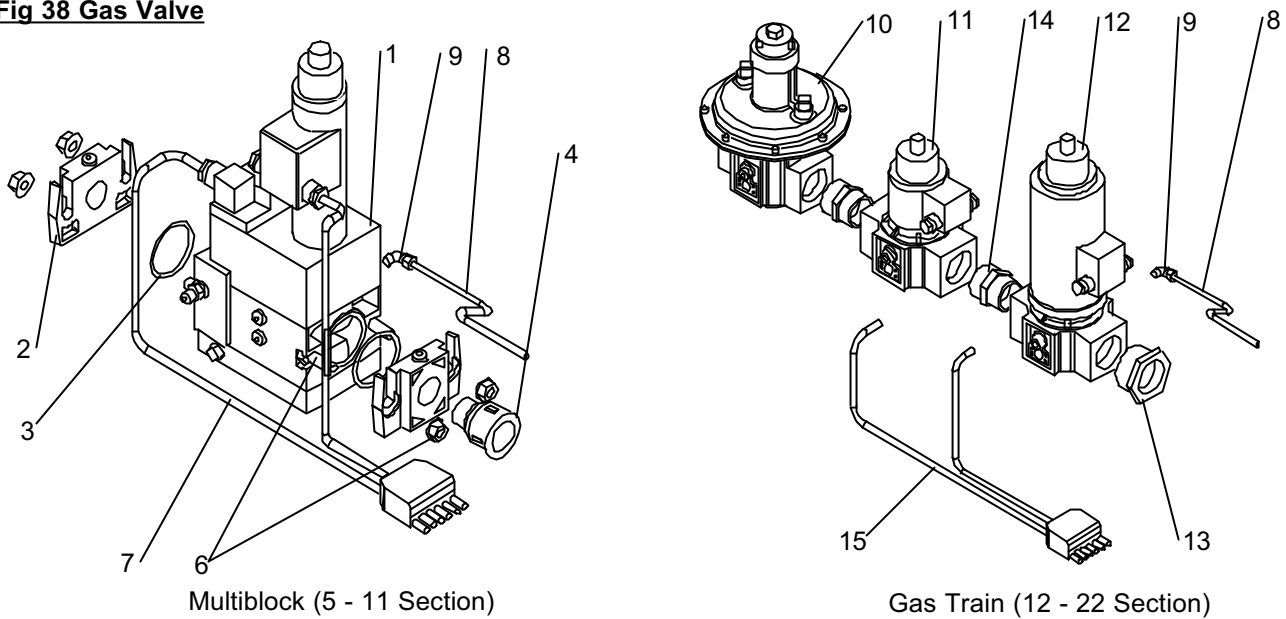

Item No.	Description	Quantity Per Boiler	Part No.
1	Multiblock Gas Valve (5 - 6 Section)	1	COMN9016670
	Multiblock Gas Valve (7 - 11 Section)	1	COMN9016680
2	Input Flange (5 Section)	1	COM17007689
	Input Flange (6 - 11 Section)	1	COMN9016660
3	O Ring (5 - 11 Section)	2	COMN
4	1" to 3/4" Reducer (5 - 11 Section)	1	COMN9125480
6	M10 Nuts	4	COM17881102
7	Multiblock Gas Valve Supply Cable	1	COM17071674
8	Pilot Tube	1	COMN7731150
9	Pilot Elbow	1	COMN9120220
10	Pressure Regulator (12 - 18 Section)	1	COM17007721
	Pressure Regulator (20 - 22 Section)	1	COM17007722
11	Gas Valve - MVD (12 - 18 Section)	1	COMN9015780
	Gas Valve - MVD (20 - 22 Section)	1	COMN9015280
12	Gas Valve - ZRDLE (12 - 18 Section)	1	COMN9015470
	Gas Valve - ZRDLE (20 - 22 Section)	1	COMN9015480
13	2" - 1 1/2" Reducer (20 - 22 Section)	1	COMN9125230
14	1 1/2" Connector (12 - 18 Section)	1	COMN9125320
	2" Connector (20 - 22 Section)	1	COMN9125330
15	Gas Valve Supply Cable	1	COM17071675

DERWENT PRESTIGE

No of Section	Description	Quantity Per Boiler	Part Number
5	Burner Assembly	1	COM17886456
6	Burner Assembly	1	COM17886457
7	Burner Assembly	1	COM17886458
8	Burner Assembly	1	COM17886459
9	Burner Assembly	1	COM17886460
10	Burner Assembly	1	COM17886461
11	Burner Assembly	1	COM17886462
12	Burner Assembly	1	COM17886463
13	Burner Assembly	1	COM17886464
14	Burner Assembly	1	COM17886465
15	Burner Assembly	1	COM17886466
16	Burner Assembly	1	COM17886467
17	Burner Assembly	1	COM17886468
18	Burner Assembly	1	COM17886469
20	Burner Assembly	1	COM17886470
22	Burner Assembly	1	COM17886471
5	Base Tray	1	COMV132609
6	Base Tray	1	COMV17934734
7	Base Tray	1	COMV17934744
8	Base Tray	1	COMV1132602
9	Base Tray	1	COMV17934764
10	Base Tray	1	COMV17934774
11	Base Tray	1	COMV17934784
12	Base Tray	1	COMV17934794
13	Base Tray	1	COMV17934804
14	Base Tray	1	COMV17934814
15	Base Tray	1	COMV17934824
16	Base Tray	1	COMV17934834
17	Base Tray	1	COMV17934844
18	Base Tray	1	COMV17934854
20	Base Tray	1	COMV17934864
22	Base Tray	1	COMV17934874
5	Insulation	4	COMV133107
6	Insulation	5	COMV133107
7	Insulation	6	COMV133107
8	Insulation	7	COMV133107
9	Insulation	8	COMV133107
10	Insulation	9	COMV133107
11	Insulation	10	COMV133107
12	Insulation	11	COMV133107
13	Insulation	12	COMV133107
14	Insulation	13	COMV133107
15	Insulation	14	COMV133107

No of section	Description	Quantity Per Boiler	Part Number
16	Insulation	15	COMV133107
17	Insulation	16	COMV133107
18	Insulation	17	COMV133107
20	Insulation	19	COMV133107
22	Insulation	21	COMV133107
5	Ceramic Fibre Length (metres)	1.600	COMN9205320
6	Ceramic Fibre Length (metres)	1.700	COMN9205320
7	Ceramic Fibre Length (metres)	1.900	COMN9205320
8	Ceramic Fibre Length (metres)	2.100	COMN9205320
9	Ceramic Fibre Length (metres)	2.200	COMN9205320
10	Ceramic Fibre Length (metres)	2.400	COMN9205320
11	Ceramic Fibre Length (metres)	2.600	COMN9205320
12	Ceramic Fibre Length (metres)	2.700	COMN9205320
13	Ceramic Fibre Length (metres)	2.900	COMN9205320
14	Ceramic Fibre Length (metres)	3.000	COMN9205320
15	Ceramic Fibre Length (metres)	3.200	COMN9205320
16	Ceramic Fibre Length (metres)	3.400	COMN9205320
17	Ceramic Fibre Length (metres)	3.500	COMN9205320
18	Ceramic Fibre Length (metres)	3.700	COMN9205320
20	Ceramic Fibre Length (metres)	4.000	COMN9205320
22	Ceramic Fibre Length (metres)	4.300	COMN9205320
5-22	Adhesive		COMV17001066

NOTE:

From May 2002 onwards the part numbers for the Pilot Body, Pilot Injector, Ignition Electrode and Ionisation Electrode on all boilers built after that date will be as follows:

Pilot Body	COM17007777
Pilot Injector	COMN5590360
Ignition Electrode	COMV134257
Ionisation Electrode	COMV133965



Brooks House, Coventry Road
Warwick CV34 4LL
Telephone 08706 050607 Fax 08706 001516

REPORT SENT TO INSTALLER:	YES		NO	
SITE VISIT (<i>Italics</i>)		COMMISSIONING		
Date:.....				
Signature:				
INSTALLER NAME & ADDRESS:				
.....				
.....				
.....				
VISIT/COMMISSIONING DATE:				

REPORT No:

SITE ADDRESS:

.....

.....

.....

1.0	BOILER			
1.1	<i>Type:</i>			
1.2	<i>No of Sections:</i>			
1.3	<i>Boiler No/Position:</i> <i>RH/LH/Centre/1/2/3/ etc</i>			
1.4	<i>Serial No:</i>			
1.5	<i>Fuel:</i>	<i>N/Gas</i>	LPG	
2.0	BURNER			
2.1	<i>Flame Detection Probe:</i>	UV Cell	Thermocouple	
2.2*	<i>Control Box Type:</i>			
2.3	<i>Electrical Supply:</i>			
2.4	<i>Main Gas Valve Type & Size:</i>			
2.5	<i>Pilot Gas Valve Type & Size:</i>			
2.6	<i>Gas Train Serial Number:</i>			
3.0	BURNER SETTINGS			
3.1	Main Burner Injector Size:		mm	
3.2	Pilot Burner Injector Size:		mm	
3.3	Are Burners & Injectors Clean?:			
3.4*	Is the Probe of the Correct Type?			
3.5	Electrode Settings as Manual?			
4.0	PRE-COMMISSIONING CHECKS (See Note)			
4.1	<u>Is boiler house ventilation as per manual?</u>			
4.2	<u>Electric supply fused, isolated & earth wire attached?</u>			
4.3	Check external controls allow operation			
4.4	Check boiler/system flooded and pumps operational and any isolation valves open			
4.5	Check gas available at burner			
4.6c	Check condensate trap fitted, filled and connected to drain with air break			
4.7	<u>Check gas meter sizing adequate</u>			
4.8	<u>Check flue system clear</u>			

5.0	COMBUSTION				
		Pilot	Low	High	Unit
5.1	Gas rate				m ³ /hr
5.2	Main Burner Pressure				mmwg
5.3*	Ionisation Probe/UV Cell Current				uA
5.4c	Air Shutter Position				-
5.5	CO2 or O2				%
5.6	CO				ppm
5.7	Gross Flue Gas Temperature				°C
5.8	Ambient Temperature				°C
5.9	Flue Draught				mmwg
5.10	Inlet Gas Pressure (Main Burner). If multi-boiler installation, inlet gas pressure all boilers high fire)				mmwg

NOTE: 5.5 to 5.9 TO BE MEASURED IN SECONDARY FLUE 600mm UP FROM THE FLUE SOCKET OR AT THE SAMPLING POINT PROVIDED (CONDENSING BOILERS ONLY). THESE MEASUREMENTS ARE INTENDED AS SAFETY CHECKS ONLY. LEVELS ARE DEPENDENT ON FLUE DRAUGHT AND SITE CONDITIONS AND HENCE CANNOT BE USED FOR COMBUSTION EFFICIENCY DETERMINATION.

- * FULLY ELECTRIC BOILERS ONLY
- ¶ THERMO-ELECTRIC BOILERS ONLY
- c CONDENSING BOILERS ONLY
- § CONVENTIONAL ATMOSPHERIC BOILERS ONLY

NOTE: It is the installer's responsibility to ensure that the boiler is correctly commissioned by a competent engineer and that this report is completed and kept as a record. A commissioning service available from Potterton at the address listed on the back page of this manual. When a Potterton engineer commissions, this completed report will be sent to the installer. It is the installer's responsibility to action any points arising. Commissioning by Potterton engineers is restricted to equipment of our supply. No responsibility is accepted for the on site assembly or installation of the equipment unless specifically carried out by Potterton. The installer must ensure that the boiler is installed in accordance with the manufacturers instructions and all relevant BS Codes of Practice and Regulations (see manufacturer's instructions for full details). Items 4.1 to 4.6 are related to the boiler installation and as such these pre-commissioning checks should be carried out in the presence of the installer.

Potterton is a Member of the Boiler & Radiator Manufacturers Association (BARMA), and the terms of this Commissioning Document follow the generally agreed conditions of the Association. Potterton, in line with its policy of continuous product development, reserves the right to alter and amend this Document as is deemed necessary at any time.

CONVERSION TABLE

	IMPERIAL TO METRIC	METRIC TO IMPERIAL
HEAT 1 Therm = 100,000 Btu/hr	1 Btu/hr = 0.291 W 1 Btu = 1055 J 1 Btu/hr = 0.252 kcal/hr	1 KW = 3412 Btu/hr 1 J = 0.0009478 Btu 1 kcal/hr = 3.968 Btu/hr
FUEL CONSUMPTION 1 dm ³ = 1 LITRE 1,000 dm ³ = 1 m ³	1 ft ³ = 28.317 dm ³ (litre) 1 UK Gall = 4.546 litre 1 UK Gall = 1.2 U.S. Gallon	1 m ³ = 35.3147 ft ³ 1 litre = 0.2199 Imp 1 U.S. Gallon = 0.83 UK Gallon
PRESSURE 1 PSI = 2.307 FT 1 kPa = 1000 Pa 1 bar = 1000 mbar = 100 kPa	1 lb/in ² = 6895 Pa 1 lb/in ² = 68.95 mbar 1 in.w.g = 249.1 Pa 1 in.w.g = 2.491 mbar 1 in.w.g = 25.4 mm.w.g	1 bar = 33.45 ft.w.g 1 kPa = 0.3345 ft.w.g 1 bar = 14.5 lb/in ² 1 Pa = 0.358 in.w.g 1 mm.w.g = 0.0394 in.w.g 1 mm.w.g = 9.8 Pa
LENGTH 1m = 1000mm	1 inch = 25.4 mm 1 ft = 0.3048 m 1 yard = 0.9144 m 1 mile = 1.609 km	1 mm = 0.03937 in 1 m = 3.281 ft 1 m = 1.094 yard 1 km = 0.6214 mile
VOLUME	1 ft ³ = 0.02832 m ³ 1 ft ³ = 28.32 litre	1 m ³ = 35.3147 ft ³ 1 litre = 0.03531 ft ³
AREA	1 in ² = 645.2 mm ² 1 in ² = 6.452 cm ² 1 ft ² = 929 cm ² 1 ft ² = 0.0929 m ²	1 mm ² = 0.00155 in ² 1 cm ² = 0.155 in ² 1 m ² = 1550 in ² 1 m ² = 10.76 ft ²
FLOW RATE 1 kg/sec = 1 lit/sec @ 0°C Reference temperature	1 gall/min = 0.7577 lit/sec 1 ft ³ /min = 0.4719 lit/sec 1 ft ³ /min = 0.00047 m ³ /sec	1 lit/sec = 13.2 gall/min 1 lit/sec = 2.119 ft ³ /min 1 m ³ /sec = 2119 ft ³ /min
TEMPERATURE	°F to °C = ("X"°F-32) x 0.5556	°C to °F = ("X"°C x 1.8) + 32
TEMPERATURE DIFFERENCE 1°C = 1°K	"X"°F x 0.5556 = °C	"X"°C x 1.8 = °F
WEIGHT	1 lb = 0.4536 kg 1 cwt = 50.8 kg 1 ton = 1016 kg	1 kg = 2.205 lb 1 tonne = 0.9842 ton 1 tonne = 2204.6 lb

Commercial Sales Technical and Service Enquiries

Potterton Commercial

Brooks House
Coventry Road
Warwick CV34 4LL

Tel: 08706 050607
Fax: 08706 001516
Sales Hotline: 08706 001991
Technical Helpline: 08706 002322
Service Hotline: 08702 412759
e-mail: commercial@potterton.co.uk
web site: www.pottertoncommercial.co.uk

Spares

Potterton Commercial spares are available nationwide through the **interpart** network of approved stockists. Alternatively please contact:-

interpart

Brooks House
Coventry Road
Warwick
CV34 4LL

Tel: 08706 000454
Fax: 08706 000545

Applications and Installations

Our experienced technical and applications team are available to offer advice on any aspect of heating system design and boiler installation.

Please contact:

Tel: 08706 002322

Commercial Service

Our service organisation covers the whole of the UK to look after your needs for all Potterton Commercial products. We are also able to offer our services for other manufacturers products.

Our service department offers a wide range of specialised services including:-

- Boiler site assembly
- Burner commissioning for all fuels
- Boiler maintenance and maintenance contracts
- Breakdown and repair services
- Boiler dismantling and re-jointing
- Burner and boiler replacement
- Oil/gas conversions
- Systems conditioning
- Water treatment and descaling
- Packaged Units

“All descriptions and illustrations contained in this leaflet have been carefully prepared but we reserve the right to make changes and improvements in our product which may affect the accuracy of the information contained in this leaflet”



h e a t i n g s p e c i a l i s t s

A Baxi Group Company

Registered Office: Pentagon House, Sir Frank Whittle Road, Derby DE21 4XA. Registered in England No.

Publication Number
M/PREST/O504