

NEW

# Ecoskid

Prefabricated Heating System  
56kW – 230kW



Working towards  
a cleaner future

**POTTERTON**  
COMMERCIAL  
heating specialists

	<i>page</i>
<b>Overview</b>	3
<b>Explanatory Image</b>	4 & 5
<b>Ecoskid Boiler Options</b>	6
<b>LZC Technology - CHP Option</b>	7 & 8
<b>Water Heater Integration</b>	9
<b>Components</b>	10
<b>Controls</b>	11 & 12
<b>Panel Wiring</b>	13
<b>Panel Mounted Connections</b>	14
<b>Dimensions</b>	15
<b>Schematic - Two Heating Zones</b>	16
<b>Schematic - Two Heating Zones plus Hot Water</b>	17
<b>Data Tables</b>	18 & 19
<b>Flueing</b>	20 - 22
<b>Testing, Delivery &amp; Installation</b>	23
<b>Warranty, Service and Service Contracts</b>	23



# Ecoskid

Prefabricated Heating System  
56kW – 230kW

## Overview

The Ecoskid has been designed to provide the market place with an easy to install, fully pre-fabricated heating system with the ability to incorporate LZC products such as the Baxi Ecogen micro-CHP. The Ecoskid can also be accompanied by a direct fired condensing water heater, such as the Andrews NEOflo which enables dedicated hot water provision. The Ecoskid offers reduced installation time on site, providing substantial cost savings and reduced system down times.

## For system selection the Ecoskid offers:

Unlike other skid assemblies on the market, the Ecoskid has the optional benefit of an onboard micro-CHP appliance, which is pre-installed and configured on the skid to enable almost any site to have the benefits of micro power generation, without the trouble of integrating these appliances in to control systems or electrical supplies.

- A choice of either a two boiler skid assembly or a single boiler installed along side a Baxi Ecogen micro-CHP unit
- The boilers can be chosen from either the Paramount two or the Sirius WH boiler (see page 6)
- Small footprint
- The Ecoskid is supplied on a fully welded, powder coated frame which can be manoeuvred easily onsite by means of forklift truck, skates or manually using rollers.
- The skid assembly has been designed to fit through a standard doorway, making it suitable for both existing and new plant rooms alike

### Onsite installation aid for the Ecoskid includes:

- Delivery to site fully assembled
- Only requires connection of the gas, flow, return and mains water pipe work to the pre-installed isolation valves
- Connection of a single phase 230V supply to the control panel
- The pressure relief pipework has been combined for ease of on site continuation to a suitable discharge point or drain
- Flexible controls for connection to a BMS or stand alone control
- Optional extra control packs to enhance the standard control panel's functionality with out the need to modify the wiring or skid assembly

### Further Options

- The Baxi Ecogen micro-CHP incorporates a Stirling engine unit which, when fired, modulates its output between 4kW and 6kW thermal, whilst generating up to 1.1kW of electricity.
- The Ecoskid can be further enhanced by the integration of the Baxi-SenerTec UK Dachs mini-CHP unit or twin coil cylinders for incorporating solar hot water production

# Ecoskid

Pre wired and installed, flexible control panel with a range of optional extras to expand its functions to meet the site requirements

Integral cable management tray

Pressurisation unit for system filling and topping up – low and high pressure alarms wired to main control panel

Commoned condensate and pressure relief pipework to aid installation

Full bore isolation valves for easy onsite connection

Pressure differential bypass to ensure minimum flow through the boilers







**Choice of two main boilers:  
Paramount two – cast  
aluminium/silicon alloy heat  
exchanger  
Sirius WH – stainless steel heat  
exchanger**

**The Ecoskid has the option of  
a Baxi Ecogen/Dachs CHP in  
place of a second boiler to offer  
substantial carbon and running  
cost reduction**

**Pressure and temperature  
gauges on common flow  
and return pipework header**

**Purge and vent points  
are pre-installed and  
plugged off**

**Gas isolation valve  
supplied to feed additional  
appliance (Andrews Water  
Heaters NEOflo)**

**Differential pressure flow  
switch for flow proving**

**Class 'A' rated energy  
efficient twin head pumps  
with automatic changeover  
and pump exercise functions**

# Ecoskid

## Ecoskid Boiler Options

The Ecoskid has been designed to take advantage of high efficiency modern condensing boilers. We offer a choice of two boilers for the Ecoskid which allows the right boiler to match the application.

### Paramount two Boilers

- Cast aluminium/silicon alloy heat exchanger
- Low NO<sub>x</sub> emissions, <20mg/kWh
- Efficiencies of up to 96% gross, seasonal
- Quick release isolation valves
- Suitable for both LPG and Natural gas



### Sirius WH Boilers

- Stainless steel heat exchanger
- Low NO<sub>x</sub> emissions, <39mg/kWh
- Efficiencies of up to 94% gross, seasonal
- Quick release isolation valves
- Suitable for both LPG and Natural gas



# LZC Technology

## Baxi Ecogen™

### What is micro-CHP?

Electricity from the national grid is generated by large, remote power stations which every year waste enough energy to heat most of our buildings. This huge waste of energy results in very inefficient and very expensive grid supplied electricity.

Micro-Combined Heat and Power (CHP) is the simultaneous generation of heat and electricity, close to the point of use. By locating micro-CHP equipment in or close to a building, the electricity generated and the heat produced can be used in the building with little energy wastage.

### Carbon saving technology

Micro-CHP is a key microgeneration technology which can deliver carbon savings of 20%-30%. It is a mature, reliable technology which delivers very attractive financial benefits and can play a big part in gaining compliance with planning and Building Regulations.

### Micro-CHP Functions

The Baxi Ecogen micro-CHP incorporates a Stirling engine unit which, when fired, modulates its output between 4kW and 6kW thermal, whilst generating up to 1.1kW of electricity. The electricity which is generated from the Baxi Ecogen is offset against the customer's electricity bills providing substantial running cost savings.

The onboard control system is configured to use the Baxi Ecogen engine as the lead appliance to maximise the benefits of using small scale micro generation and maximise



the reduction in carbon emissions. If the load is greater than 6kW, the main boiler is then brought in to operation to satisfy this demand. At peak times the auxiliary burner on the Baxi Ecogen will then be brought in to operation to provide a final heat source.

### Energy efficiency comparison

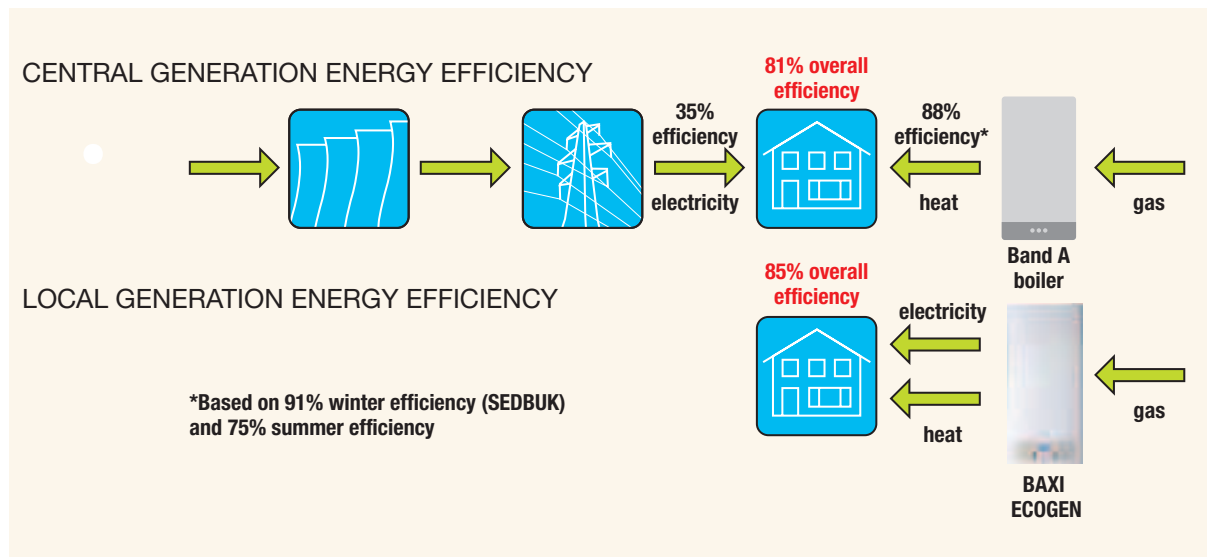

# LZC Technology

### Baxi Ecogen micro-CHP Option

The Ecoskid can be provided with an integral Baxi Ecogen micro-CHP unit. This reduces the carbon footprint of the system by displacing the CO<sub>2</sub> emissions associated with the system by displacing the CO<sub>2</sub> emissions associated with gas fired power generation of electricity. The Baxi Ecogen reduces the operational cost of the site by reducing the electrical requirement purchased from the electrical supplier. The control system automatically utilises the Baxi Ecogen as the lead boiler to maximise the carbon reduction associated with micro-CHP technology.

### Baxi Ecogen Performance Details

- 6kW Thermal output @ 1.1kW Electrical output
- 18kW additional thermal output from additional burner
- 90% overall operating efficiency
- Low noise <45dB(A) @ 1M
- Maintenance free sealed sterling engine

### Baxi Ecogen CO<sub>2</sub> Emission Reduction

- 0.359kg/Hr CO<sub>2</sub> reduction at 6kW base load
- Annual CO<sub>2</sub> reduction up to 3,136 Kg

### Electrical Grid Reduction

- 8,760kWh per annum at 6kW thermal base load
- Annual saving at £0.12p kWhr = £1,051



### Conventional set-up

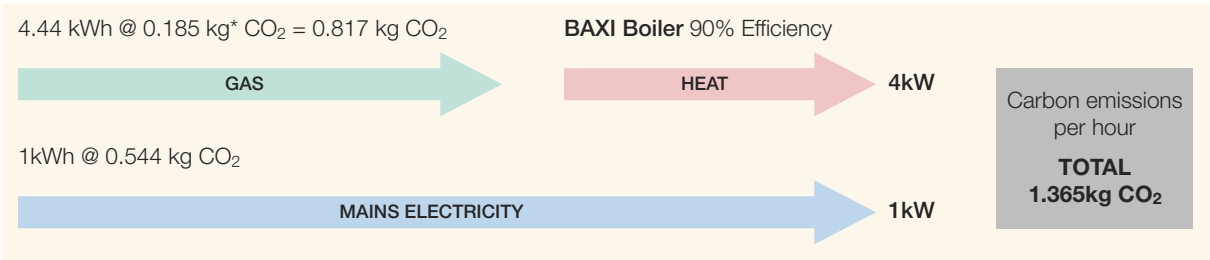

### Set-up with Baxi Ecogen

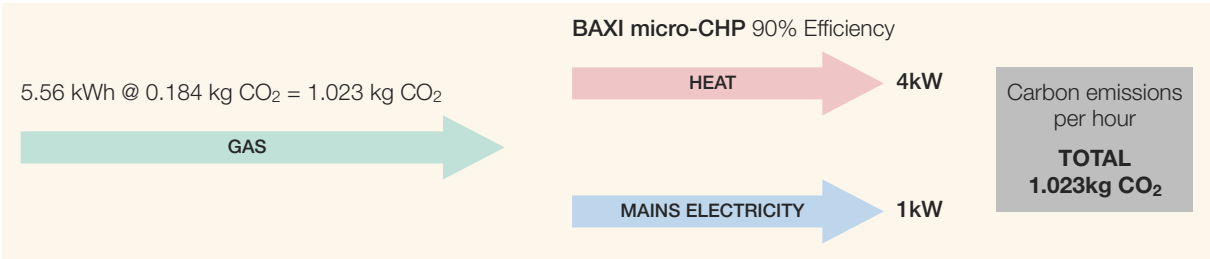

\*CO<sub>2</sub> emission in ex figures sourced from Carbon Trust (Feb 2011)



# Ecoskid

## Water Heater Integration

The Ecoskid has been designed to work alongside our highly efficient appliances from the Baxi Commercial Division range. The Ecoskid has the facility to feed an additional appliance like the NEOflo, with both electric and gas services being fed directly from the Ecoskid.

The NEOflo range of condensing direct-fired storage water heaters are the latest models to emerge from market leading Andrews Water Heaters. Employing a single upward firing pre-mix burner technology, NEOflo offers high fuel efficiencies and ultra low NOx of around 25ppm, satisfying the increasing demands of stringent building regulations.

NEOflo water heaters utilise highly durable stainless steel internal storage cylinders with available capacities of 200 litres, 300 litres and 400 litres and an impressive recovery rate of 430 litres per hour.

The low internal pressure loss across the stainless steel heat exchanger and internal water way enables NEOflo water heaters to operate in those areas of the country where low water pressure is prominent.

Available as a room sealed or conventional flued appliance, NEOflo offers flexibility with regard to the location of the water heater and discharge of the products of combustion.

A digital Human Machine Interface is present on the appliance displaying key parameters with the ability to connect to an on-site Building Management System (BMS) for control and supervision.



# Ecoskid

## Components

### System Pumps

- Class 'A' rated intelligent pumps
- Twin head assembly arranged in a duty/standby configuration
- Differential pressure switch for flow proving, complete with automatic changeover
- Choice of operation modes selected using the inbuilt pump controls



### Arrow Fill Unit

- Inbuilt and configured Arrow pressurisation unit
- Integral high and low pressure switches pre-wired to the main system controls
- Low water pressure alarm
- Onboard LCD for setting system and alarm pressures



### Pressure and Temperature Gauges

- 80mm combined temperature and pressure gauges
- Gauges fitted with isolation valves for easy service/maintenance



### Differential Pressure Bypass

- Pressure set bypass valve fitted across the flow and return
- Guarantees the minimum flow rate through boilers when external controls shut down



# Ecoskid

## Controls

The Ecoskid has a built in and pre-configured control panel that offers a great deal of flexibility and integration. The control panel is supplied pre-wired with all looms secured to the onboard cable management system, meaning the installer only needs to connect the single phase 230v supply to the control panel, saving both time and material costs on having to install and integrate control systems.

The standard panel comes ready for BMS integration and has connections. Available for monitoring the status of the main system components and for controlling the system using a 0 – 10v signal (Relating to 0 – 100% of total system output). See page 14 for more details on the available connections for monitoring and BMS integration.



Where these optional extra packs are used, you will find behind the label on the rear of the door, all the connections to complete the installation of these packs. Optional packs are provided for:



- Weather compensated controller
- Constant flow temperature controller
- Time control (for use with a constant temperature or weather compensated controls)
- Frost protection (3 Stage)
- Additional isolator for water heater integration

The controls for the Ecoskid require no more than single phase 230v 50hz supply to be connected directly in to the control panel. Each piece of equipment has a MCB to offer protection and an individual isolator to enable each piece of equipment to be isolated individually with out the need to shut down the rest of the system for ease of maintenance.



When either the constant flow or weather compensator controls are used, they provide the 0 – 10v signal and can be used as a stand alone control option either with or without a time switch.

If a BMS is still used to enable and monitor the system the BMS 0 – 10v input connections can now be used to monitor the output of the system (0 – 100% of total system output).

The front panel has a number of blank labels that can be changed by removing the four screws and fitting an alternative label. This facility has been provided to allow the control panel to be expanded with the use of optional extra packs.



The 0 – 10V signal from either of the methods above, is fed in to a robust and reliable Mitsubishi PLC which controls the system by sequencing and modulating the boilers to closely match the system demand whilst ensuring the system operates at its most efficient by utilising the various heat sources in the correct sequence.



# Ecoskid

## Controls

### Sequence of Operation

The PLC will always bring on the Baxi Ecogen engine (If a Baxi Ecogen version is requested), as using the engine for as long as possible will maximise both the carbon savings and electrical output from the micro-CHP.

If this does not satisfy the load, the condensing boiler will be brought in to operation and modulated to match the heat demand.

At peak heat demand, the auxiliary burner on the Baxi Ecogen will fire to provide a final source of heat.

### Pump/Flow Monitoring

The PLC will monitor the pump and flow conditions of the system and ensure that both pumps are operated equally in respect to hours run. The PLC will monitor for flow fail and bring on the standby pump should a flow fail condition be observed. Each pump is operated once a week to ensure the pump heads do not seize during periods of non-use.

Flow proving is provided by a differential pressure switch.

### Frost protection

Frost protection is provided via an optional extra pack that is supplied with an outside thermostat and two immersion stats that fit in to the pockets provided on the return pipe. Once fitted, the frost protection will be activated once a user set temperature is observed by the outside thermostat. This will operate the pumps until the outside temperature increases and this thermostat is satisfied.

Once the frost protection is activated and the pumps are running, the system then monitors the return pipe temperature. If the temperature is below a user set value, the system will start the Baxi Ecogen engine to provide an input of up to 6kW (On twin boiler versions the system operates

Boiler No1 and modulates it as required). This engine will operate as required until either the temperature rises above the thermostats trigger point or the temperature drops past the user set value for the second frost immersion thermostat. If this second immersion thermostat is triggered, the system will then allow the second boiler to fire to provide full load in to the system to ensure the building is protected at all times, whilst operating as efficiently as possible.

### Hot Water Functions

The Ecoskid caters for hot water integration in a number of ways, either by using a dedicated water heater fed from the Ecoskid or by means of a temperature boost function. If the system is fitted with the weather compensated controller, the system may not be operating at a high enough temperature during mild periods to provide hot water. This can be overcome by giving the system an override signal (via vfc) which will enable the Ecoskid to operate at maximum temperature until the hot water is satisfied and the override signal removed. An end switch on a three way diverter valve can be used for this purpose. Once the signal has been removed, the system will revert back to the temperature requested from the controller. This enables the system to operate in condensing mode for as long as possible while still supplying your hot water requirements.

See page 14 for more information on the electrical connection of optional extra packs.

# Ecoskid

## Panel Wiring

### Available Inputs

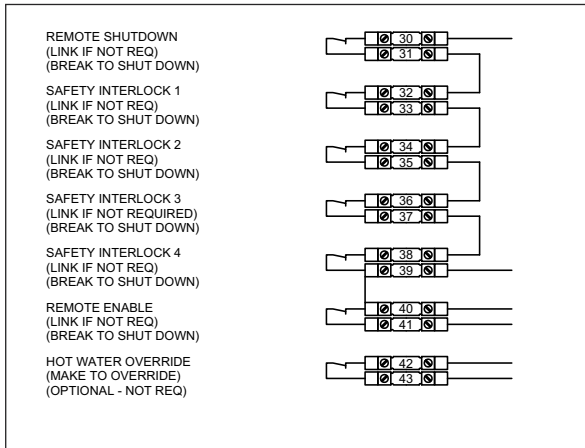

### Sensor Connections

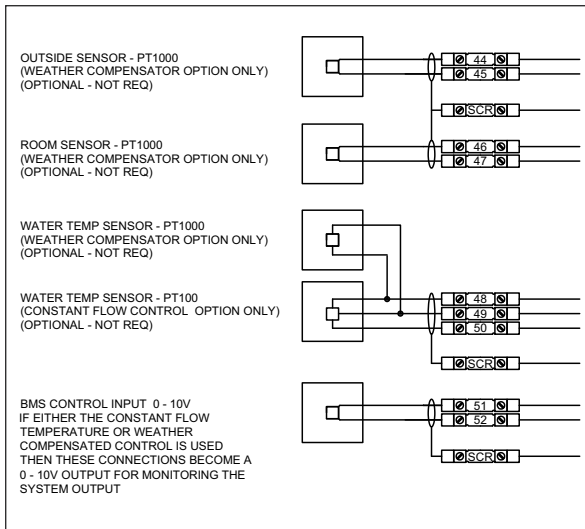

### Optional Pack Connections

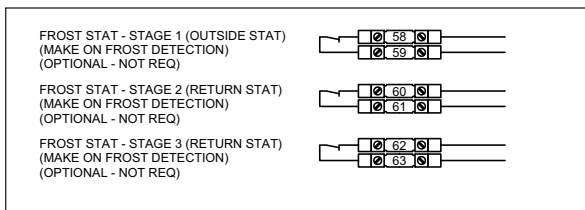

### Alarm Telemetry Connections

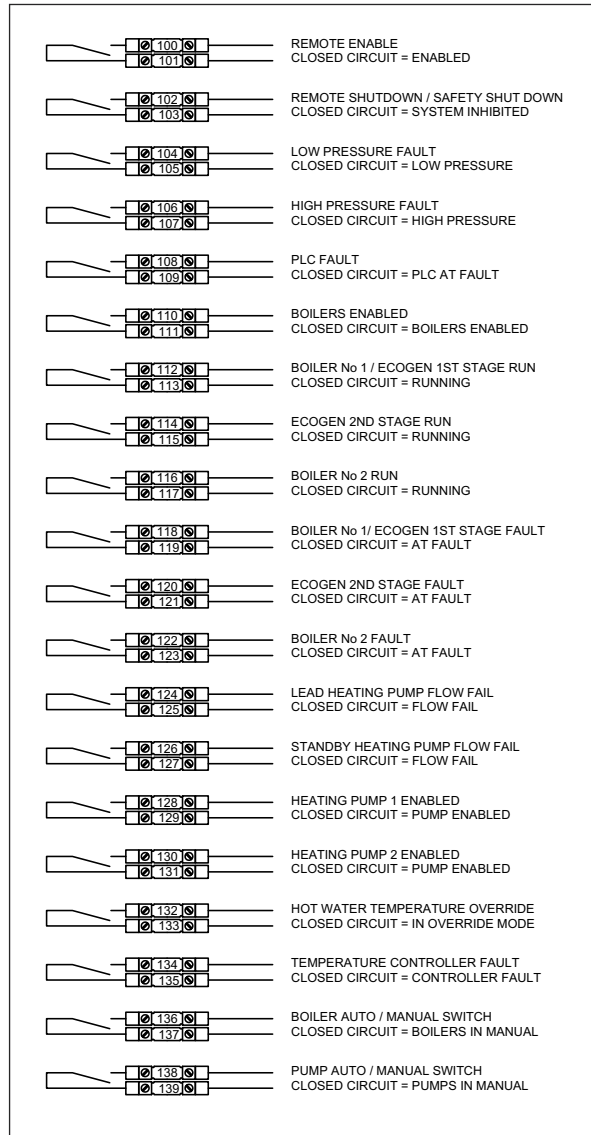



# Ecoskid

## Panel Mounted Connections – Optional Extras Pack

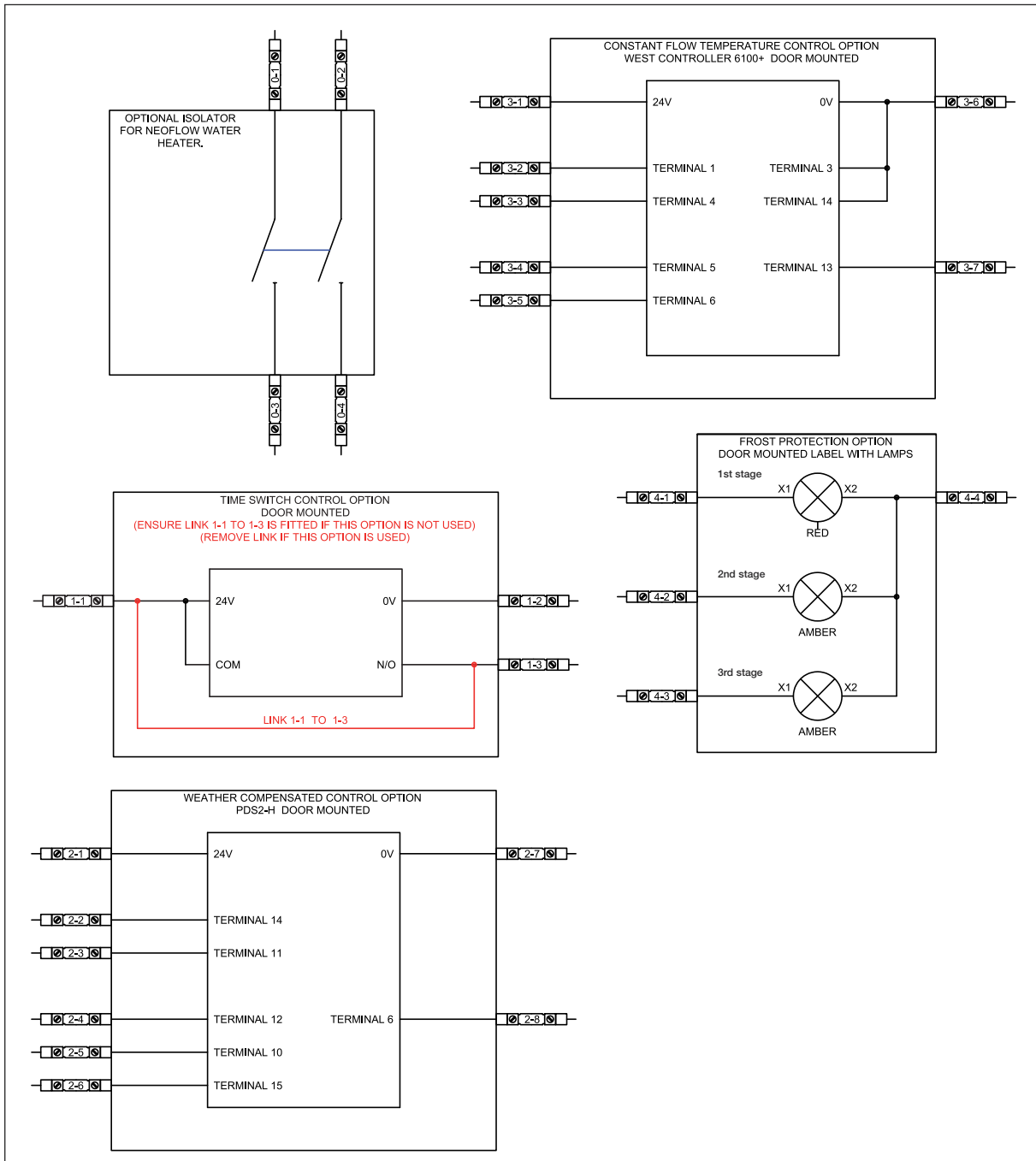

# Ecoskid

## Dimensions

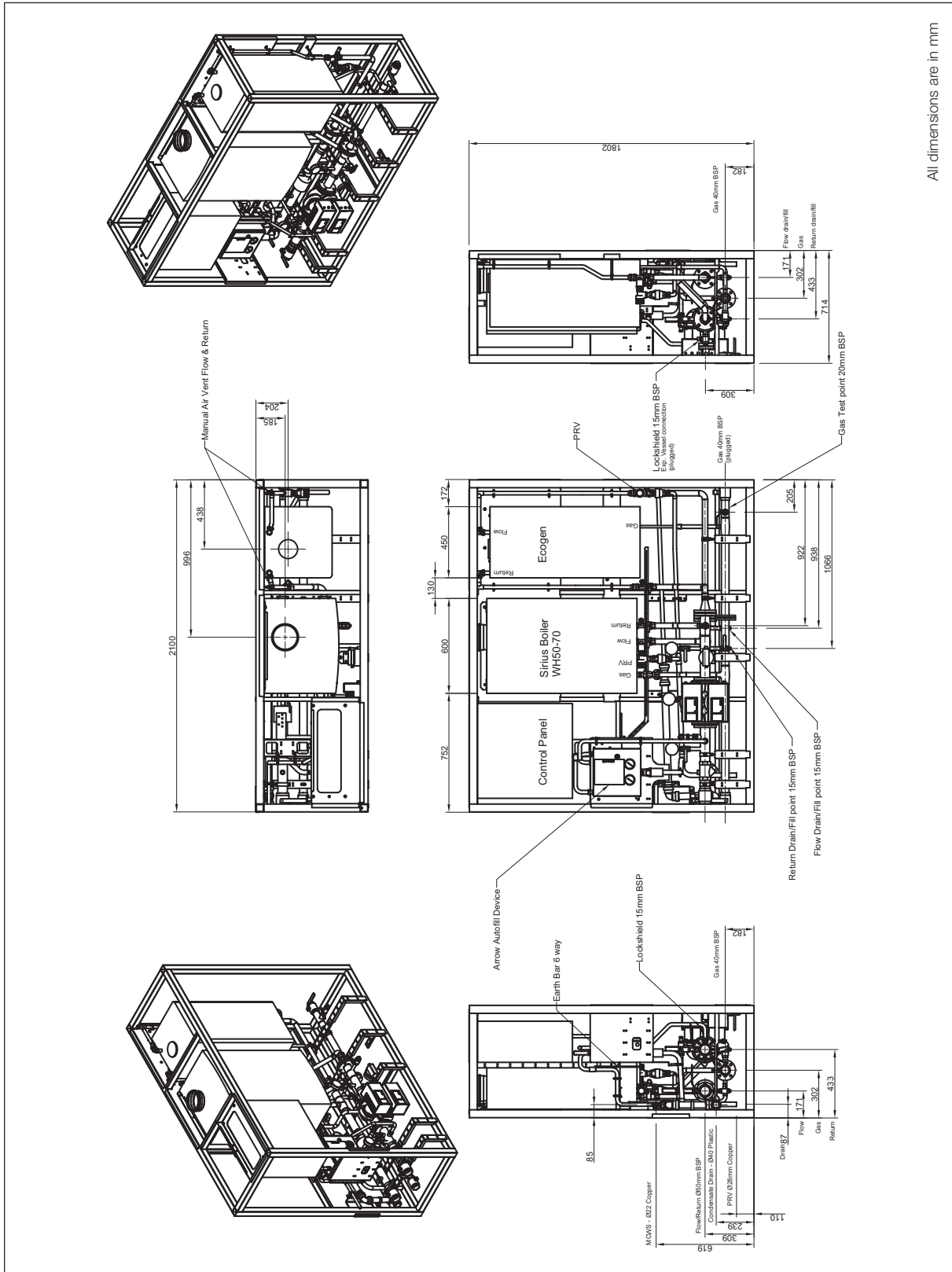

All dimensions are in mm

# Ecoskid

## Schematic – 2 Heating Zones

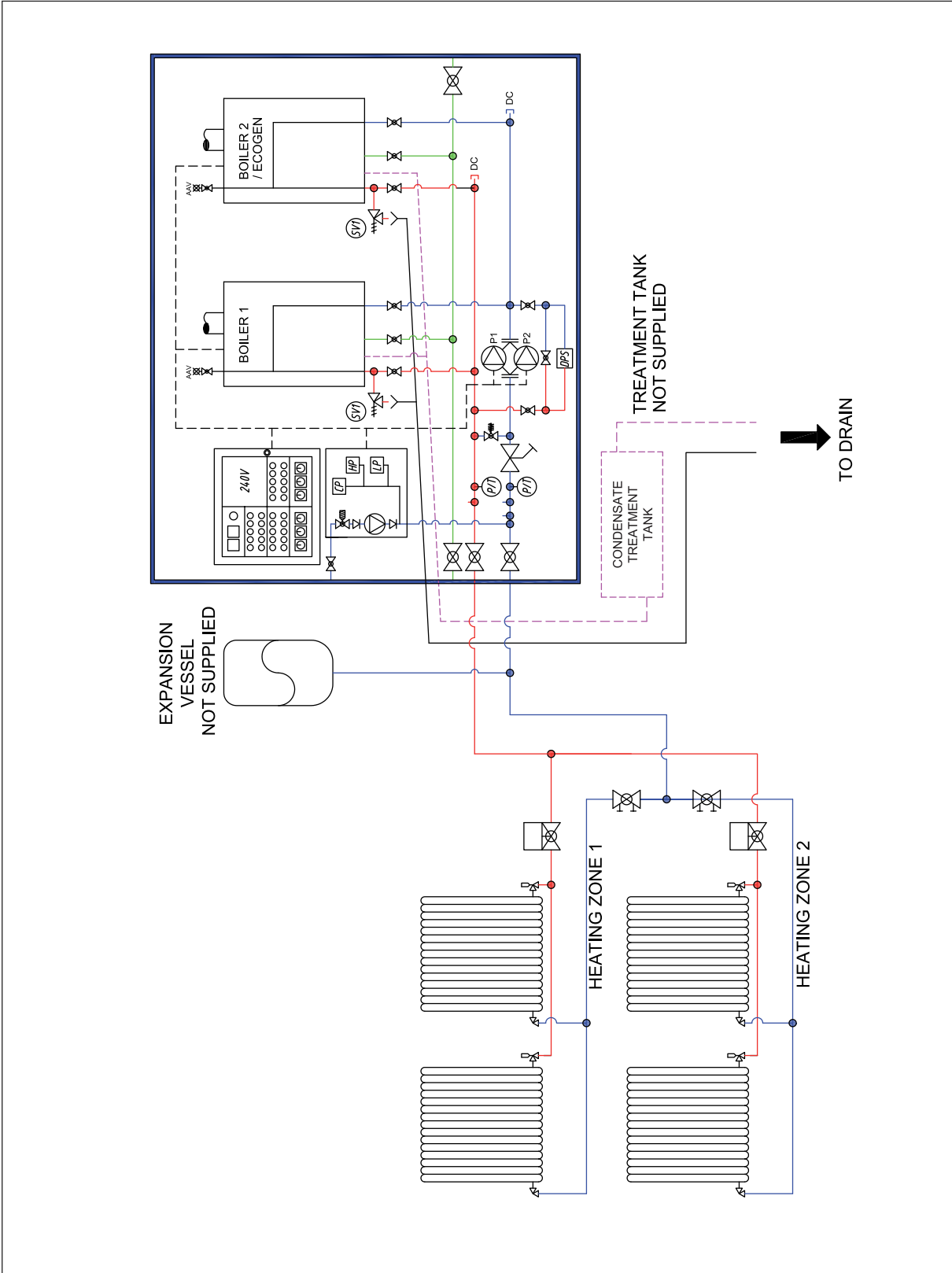

# Ecoskid

## Schematic – 2 Heating Zones plus Hot Water

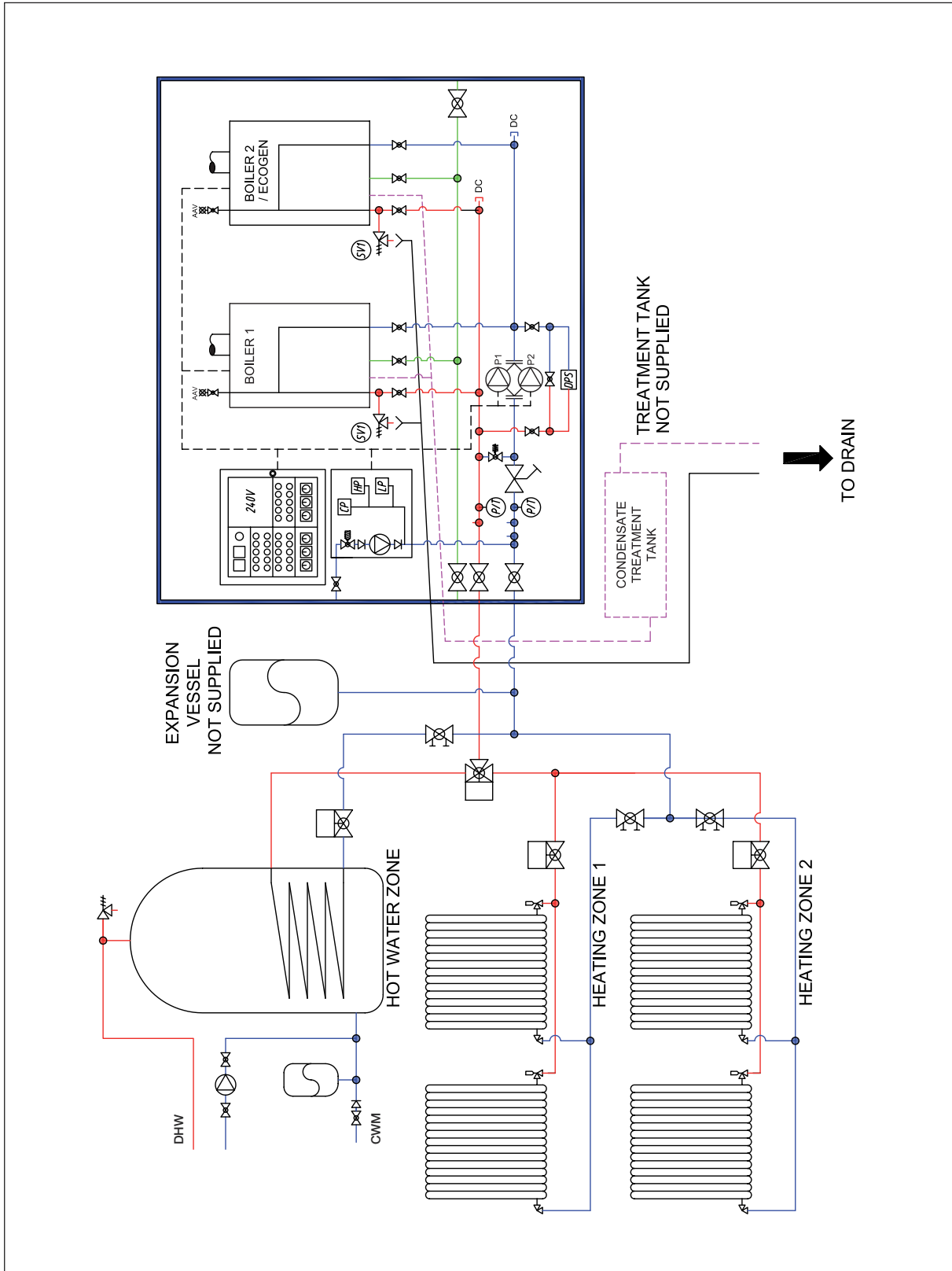

# Ecoskid Data Tables

## Paramount and Baxi Ecogen CHP

MODEL NUMBER	Unit	ECO-P56E	ECO-P66E	ECO-P86E	ECO-P106E	ECO-P121E	ECO-P141E
<b>Boiler 1 Size (Max Output)</b>	kW	30	40	60	80	95	115
<b>Mini-CHP Size (Max Output)</b>	kW	26	26	26	26	26	26
<b>Total Output (Min/Max)</b>	kW	56	66	86	106	121	141
<b>Gas Consumption @ Max Output – Nat Gas</b>	M <sup>3</sup> /Hr	5.66	6.46	8.46	10.46	12.56	14.66
<b>Gas Consumption @ Max Output – LPG</b>	M <sup>3</sup> /Hr	2.18	2.49	3.26	4.03	4.83	5.64
<b>Nominal Inlet Gas Pressure (Nat Gas/LPG)</b>	mbar	19–23 / 35–39					
<b>Available External Pump (Head – Flow Rate @ 20Δ°C)</b>	kPa – Ltr/sec	101.15 kPa @ 0.67	101.15 kPa @ 0.79	101.15 kPa @ 1.03	98.59 kPa @ 1.27	97.41 kPa @ 1.45	99.09 kPa @ 1.69
<b>Electrical Supply Voltage</b>	V / Hz	230/50	230/50	230/50	230/50	230/50	230/50
<b>Power Consumption @ Max Flow (Start/Run)</b>	A	7.94 / -0.9	7.96 / -0.88	8.00 / -0.84	8.15 / -0.69	8.44 / -0.4	8.85 / -0.01
<b>External Flue Size (Boilers/Baxi Ecogen CHP)</b>	mm	80/125 60/100	80/125 60/100	110/160 60/100	110/160 60/100	110/160 60/100	110/160 60/100
<b>Hydraulic Operating Pressure (Min/Max)</b>	Bar	1bar–3bar	1bar–3bar	1bar–3bar	1bar–3bar	1bar–3bar	1bar–3bar
<b>Maximum Flow Temperature</b>	°C	80	80	80	80	80	80
<b>Skid Weight (Empty)</b>	kg	486	486	494	505	517	517

## 2 x Paramount Boilers

MODEL NUMBER	Unit	ECO-P60	ECO-P80	ECO-P120	ECO-P160	ECO-P190	ECO-P230
<b>Number of Boilers</b>		2 x 30kW	2 x 40kW	2 x 60kW	2 x 80kW	2 x 95kW	2 x 115kW
<b>Total Output (Min/Max)</b>	kW	60	80	120	160	190	230
<b>Gas Consumption @ Max Output – Nat Gas</b>	M <sup>3</sup> /Hr	6.4	8	12	16	20.2	24.4
<b>Gas Consumption @ Max Output – LPG</b>	M <sup>3</sup> /Hr	2.46	3.08	4.62	6.15	7.77	9.38
<b>Nominal Inlet Gas Pressure (Nat Gas/LPG)</b>	mbar	19 - / 35 – 39					
<b>Available External Pump (Head – Flow Rate @ 20Δ°C)</b>	kPa – Ltr/sec	108.72 kPa @ 0.72	103.81 kPa @ 0.96	109.94 kPa @ 1.44	109.14 kPa @ 1.91	104.31 kPa @ 2.27	98.16 kPa @ 2.75
<b>Electrical Supply Voltage</b>	V	230/50	230/50	230/50	230/50	230/50	230/50
<b>Power Consumption @ Max Flow (Start/Run)</b>	A	3.68 / 3.44	3.72 / 3.46	3.80 / 3.49	4.10 / 3.65	4.68 / 3.94	5.5 / 4.35
<b>External Flue Size</b>	mm	80 / 125	80 / 125	110 / 160	110 / 160	110 / 160	110 / 160
<b>Hydraulic Operating Pressure (Min/Max)</b>	Bar	1bar–3bar	1bar–3bar	1bar–4bar	1bar–4bar	1bar–4bar	1bar–4bar
<b>Maximum Flow Temperature</b>	°C	85	85	85	85	85	85
<b>Skid Weight (Empty)</b>	kg	424	424	440	462	486	486



## Sirius and Baxi Ecogen CHP

MODEL NUMBER	Unit	ECO-S76E	ECO-S86E	ECO-S96E	ECO-S116E	ECO-S136E
Boiler 1 Size (Max Output)	kW	50	60	70	90	110
Mini-CHP Size (Max Output)	kW	26	26	26	26	26
Total Output (Min/Max)	kW	76	86	96	116	136
Gas Consumption @ Max Output – Nat Gas	M <sup>3</sup> /Hr	7.37	8.46	9.54	11.68	13.56
Gas Consumption @ Max Output – LPG	M <sup>3</sup> /Hr	2.84	3.26	3.67	4.50	5.22
Nominal Inlet Gas Pressure (Nat Gas/LPG)	mbar	19 – 23 / 35 – 39				
Available External Pump (Head – Flow Rate @ 20Δ°C)	kPa – Ltr/sec	101.15 kPa @ 0.91	99.34 kPa @ 1.03	98.43 kPa @ 1.14	98.21 kPa @ 1.39	97.32kPa @ 1.63
Electrical Supply Voltage	V / Hz	230/50	230/50	230/50	230/50	230/50
Power Consumption @ Max Flow (Start/Run)	A	8.35 / -0.49	8.39 / -0.45	8.78 / -0.06	9.02 / 0.18	9.44 / 0.60
External Flue Size (Boilers/Baxi Ecogen CHP)	mm	80/125 60/100	80/125 60/100	80/125 60/100	110/160 60/100	110/160 60/100
Hydraulic Operating Pressure (Min/Max)	Bar	1bar–3bar	1bar–3bar	1bar–3bar	1bar–3bar	1bar–3bar
Maximum Flow Temperature	°C	80	80	80	80	80
Skid Weight (Empty)	kg	496	501	505	515	519

## 2 x Sirius Boilers

MODEL NUMBER	Unit	ECO-S100	ECO-S120	ECO-S140	ECO-S180	ECOP-S220
Number of Boilers		2 X 50kW	2 x 60kW	2 x 70kW	2 x 90kW	2 x 110kW
Total Output (Min/Max)	kW	60	80	120	160	190
Gas Consumption @ Max Output – Nat Gas	M <sup>3</sup> /Hr	8.82	12	15.6	18.44	22.2
Gas Consumption @ Max Output – LPG	M <sup>3</sup> /Hr	3.78	4.62	6.00	7.09	8.54
Nominal Inlet Gas Pressure (Nat Gas/LPG)	mbar	19–23 / 35–39				
Available External Pump (Head – Flow Rate @ 20Δ°C)	kPa – Ltr/sec	104.76 kPa @ 1.20	97.34 kPa @ 1.44	93.78 kPa @ 1.67	92.22 kPa @ 2.15	91.06 kPa @ 2.63
Electrical Supply Voltage	V	230/50	230/50	230/50	230/50	230/50
Power Consumption @ Max Flow (Start/Run)	A	4.5 / 3.85	4.58 / 3.89	5.36 / 4.28	5.84 / 4.52	6.68 / 4.94
External Flue Size	mm	80 / 125	80 / 125	80 / 125	110 / 160	110 / 160
Hydraulic Operating Pressure (Min/Max)	Bar	1bar–3bar	1bar–3bar	1bar–4bar	1bar–4bar	1bar–4bar
Maximum Flow Temperature	°C	85	85	85	85	85
Skid Weight (Empty)	kg	446	454	462	482	490

# Ecoskid

## Flueing

### Open Flue

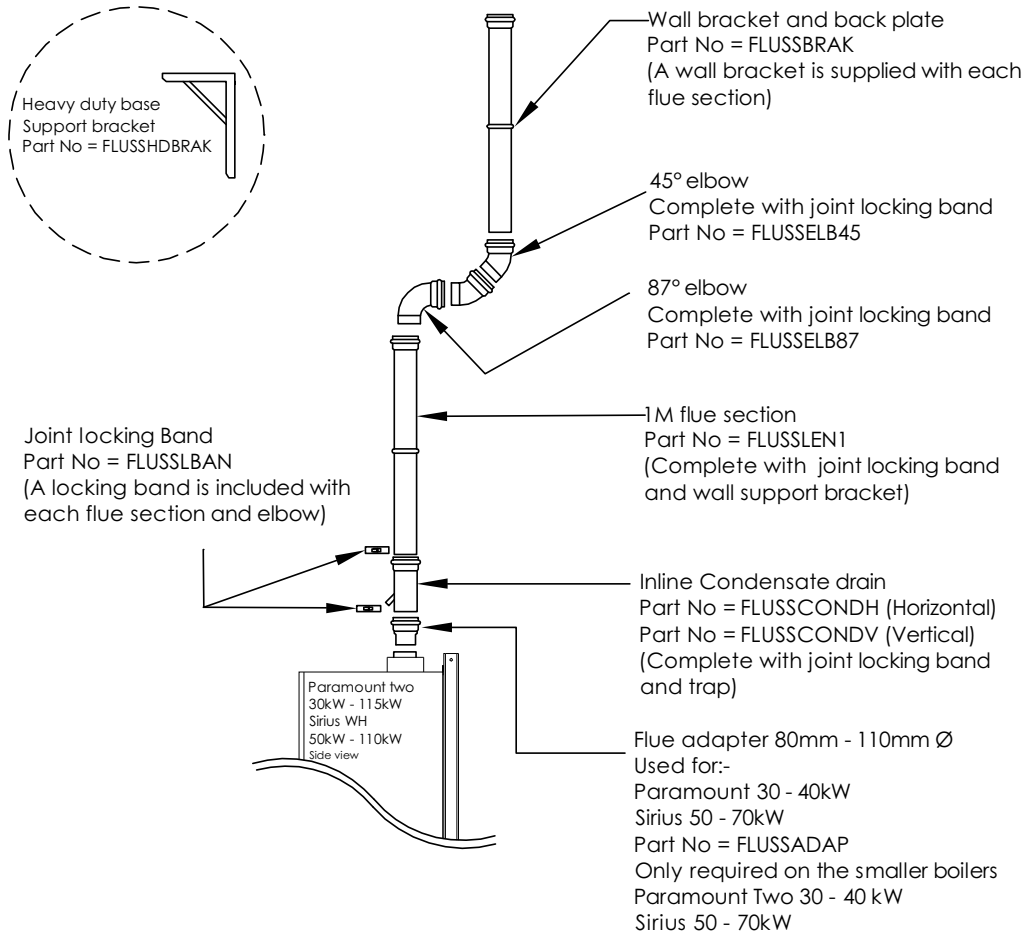

Boiler Type	Boiler Size	Maximum total flue length	Maximum horizontal flue length	Maximum number of bends
Sirius WH	50 kW	59.5m	3m	4
Sirius WH	70 kW	59.5m	3m	4
Sirius WH	90 kW	19.5m	3m	2
Sirius WH	110 kW	19.5m	3m	2
Paramount two	30 kW	20m	3m	3
Paramount two	40 kW	20m	3m	3
Paramount two	60 kW	25m	3m	3
Paramount two	80 kW	16m	3m	3
Paramount two	95 kW	20m	3m	2
Paramount two	115 kW	20m	3m	2

Each 87° bend reduces the total flue length by 1000mm. Each 45° bend reduces the total flue length by 500mm. The condensate drain also reduces the overall flue length by 1000mm. All horizontal flue sections should be installed ensuring there is a 3° rise along its length. A condensate drain must be installed as close to the boiler as possible.

## Balanced Horizontal Flue

The part numbers for the Sirius WH 50 – 70kW and the Paramount two 30 – 40kW are shown in **red**.

The part numbers for the Sirius WH 90 – 110kW and the Paramount two 60 – 115kW are shown in **blue**.

All components come with a joint locking band, although additional

bands are available using the part numbers below.

All flue lengths and terminal pieces include a flue support bracket. Additional brackets are available using the part numbers below.

The horizontal terminal section comes complete with a wall tidy plate.

For Sirius WH boilers from 90 – 110kW and the Paramount two 60 – 115kW boilers require an adaptor to be fitted directly on to the boiler before using the flue components below. This adaptor is included in each horizontal flue terminal kit.

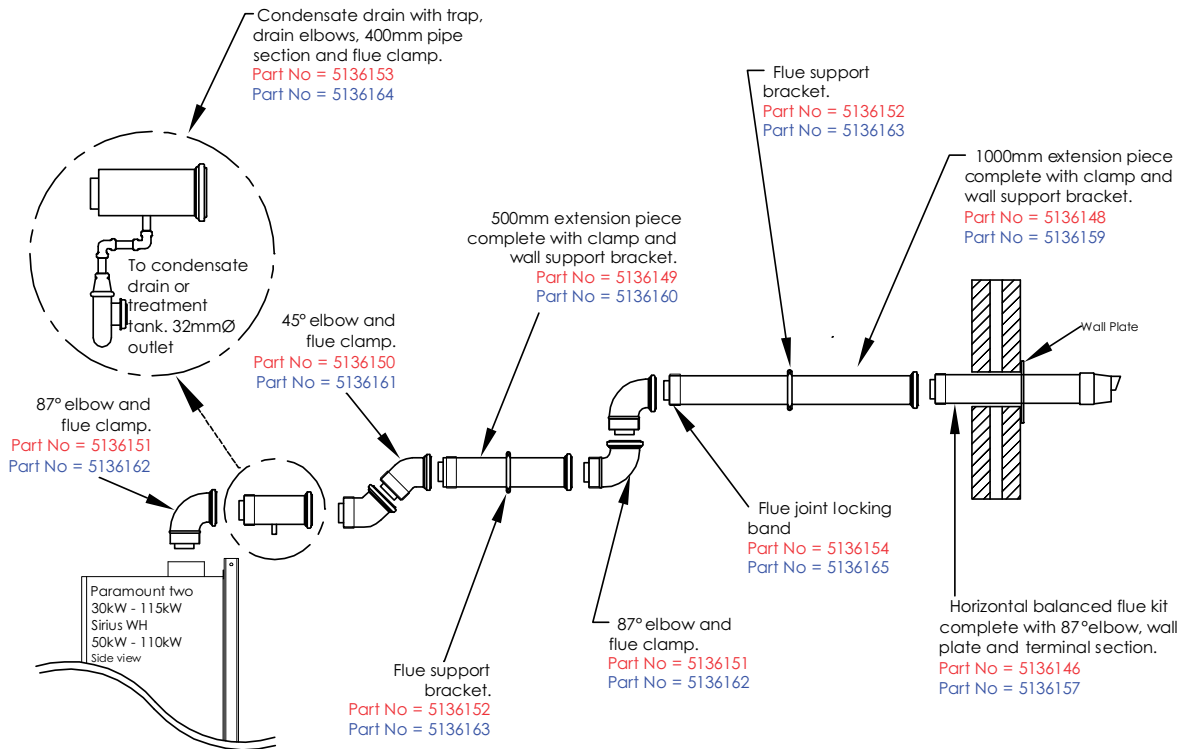

Boiler Type	Boiler Size	Maximum total flue length	Maximum number of 87° bends	Flue size InletØ – OutletØ
Sirius WH	50 – 70 kW	9m	4	80 – 125mmØ
Sirius WH	90 – 110 kW	9m	4	100 – 150mmØ
Paramount Two	30 – 40 kW	10m	2	80 – 125mmØ
Paramount Two	60 – 110 kW	5m	2	100 – 150mmØ

Each 87° bend reduces the total flue length by 1000mm. Each 45° bend reduces the total flue length by 500mm. All horizontal flues should be installed ensuring there is a 3° rise along its length. Each condensate drain reduces the total flue length by 1000mm.

# Ecoskid

## Flueing

### Balanced Vertical Flue

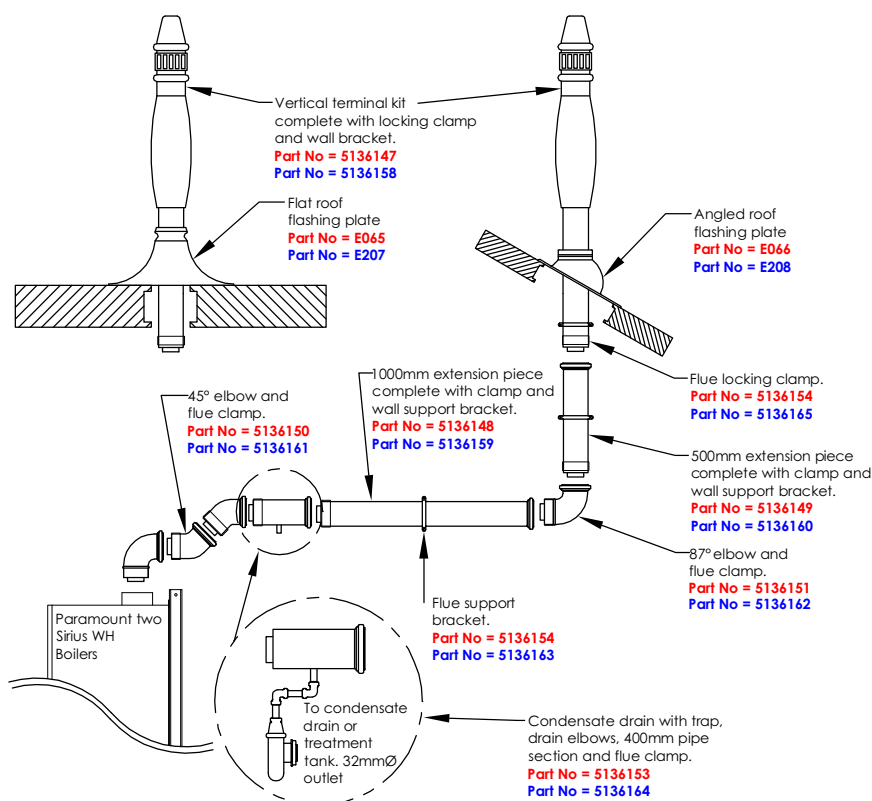

The part numbers for the Sirius WH 50 – 70kW and the Paramount two 30 – 40kW are shown in red.

The part numbers for the Sirius WH 90 – 110kW and the Paramount two 60 – 115kW are shown in blue.

All components come with a joint locking band although additional bands are available using the part numbers below.

All flue lengths and terminal pieces include a flue support bracket although additional brackets are available using the part numbers below.

For Sirius WH boilers from 90-110kW and the Paramount two 60 – 115kW boilers, an adaptor is required to be fitted directly on to the boiler before using the flue components below. This adaptor is included in each vertical flue terminal kit.

Boiler Type	Boiler Size	Maximum total flue length	Maximum horizontal flue length	Maximum number of 87° bends
Sirius WH	50 – 70 kW	9m	3m	4
Sirius WH	90 – 110 kW	9m	3m	4
Paramount Two	30 – 40 kW	7m	3m	2
Paramount Two	60 – 110 kW	7m	2m	2

Each 87° bend reduces the total flue length by 1000mm. Each 45° bend reduces the total flue length by 500mm.

All horizontal flue sections should be installed ensuring there is a 3° rise along its length.

Each condensate drain reduces the total flue length by 1000mm.

A condensate drain must be fitted as close as possible to the boiler before any long runs of flue.

# Ecoskid

## Testing, Delivery, Installation, Warranty, Service

### Testing

At Potterton Commercial we ensure your products are supplied thoroughly tested and fit for purpose. The Ecoskid is no different and we undergo a lengthy quality assurance process to ensure the highest quality of our products.

This process starts right at the stage of order where a project engineer will contact the customer to ensure the Ecoskid meets the site requirements and optional extras that are required, are ordered correctly.

During the fabrication of the Ecoskid, regular visits are made to the factory floor by our project engineers to ensure all elements of the construction are completed to high standards and are as per the Ecoskid design.

Once the unit is factory complete and ready for collection the assembly undergoes electrical tests in accordance with the current IEE wiring regulations and a full functionality

test to ensure the controls and components operate as designed and are free from fault.

A full factory test report will be supplied to each customer after delivery.

### Delivery

Delivery of the Ecoskid will be organised to a suitable position as close as is practical to the plant room. Delivery will be made to the kerbside, on-site manoeuvring equipment is to be supplied by others.

The Ecoskid will be supplied fixed to a pallet by means of removable brackets. This allows the Ecoskid to be easily manoeuvred around site by means of a forklift or pallet truck.

Onsite manoeuvring can also be achieved by removing the pallet and using skates or rollers, which can be removed when the Ecoskid is in its final position.

### Commissioning

At Potterton Commercial we like to ensure that the appliances are set up and configured correctly and best match the sites needs. To this end we offer a full range of commissioning visits to our customers or installers to ensure the system is set up to operate at its most efficient and reliable operating condition.

As with our factory testing, a full commissioning report will be supplied to each customer and will ensure the Ecoskid qualifies for its warranty.

During this commissioning visit, Potterton Commercial can instruct site operatives on the setup, control and operation of the Ecoskid.

## Warranty, Service and Service Contracts

### Warranty

Potterton Commercial offers up to a 2 year warranty\* on the Ecoskid, to cover parts and labour in the event of manufacturing defect of any component.

This warranty is subject to installation, service and maintenance in accordance with the supplied installation and maintenance instructions.

### Service

We have our own team of direct employed engineers 'Heateam Commercial' supported by a network of agents which allows us to provide national coverage to all our equipment.

With this team behind us we can

support all our brands and the development of the new technologies, working in harmony with traditional technologies.

We offer proactive servicing and change the appliances consumable components at the time of the service. This ensures the greatest reliability of our products between service visits and reduces breakdowns and system down times.

Our experienced team of fully qualified and equipped engineers are all Gas Safe registered operatives and are able to work on both Natural gas and LPG appliances.

### Service Contracts

With an individually tailored service contract for your site we can service the equipment and proactively replace consumable components ensuring the products continue to operate at their most efficient. This will also entitle you to the additional support of future reduced labour rates and reduced price on any spare parts required, subject to terms and conditions.

\*Subject to terms and conditions



## Commercial Sales Technical & Service Enquiries

Sales: 0845 070 1056  
Technical: 0845 070 1057  
Fax: 0845 070 1059  
e-mail: [potterton.commercial@baxicommercialdivision.com](mailto:potterton.commercial@baxicommercialdivision.com)  
web: [www.pottertoncommercial.co.uk](http://www.pottertoncommercial.co.uk)

## Spares

Potterton Commercial spares are available nationwide through the interpart network of approved stockists. Alternatively please contact:-

### Interpart

Brooks House  
Coventry Road  
Warwick CV34 4LL  
Tel: 0844 871 1540

## Applications & Installations

Our experienced technical support team are available to offer advice on any aspect of heating system design and boiler installation.

Please contact: 0845 070 1073

## Commercial Service Offices

Our service organisation covers the whole of the UK to look after your needs for all Potterton Commercial products.

Our service office offers a wide range of specialised services including:

- Burner commissioning for all fuels
- Boiler service contracts
- Breakdown and repair services
- Burner and boiler replacement
- Oil/gas conversions
- Water treatment and descaling
- Packaged units

All descriptions and illustrations contained within this leaflet have been carefully prepared, but we reserve the right to make changes and improvements in our products which may affect the accuracy of the information in this leaflet.

PART OF BDR THERMEA

**Baxi Commercial Division**  
Wood Lane, Erdington,  
Birmingham B24 9QP

Sales: **0845 070 1056**      Technical: **0845 070 1057**

Email: [potterton.commercial@baxicommercialdivision.com](mailto:potterton.commercial@baxicommercialdivision.com)  
[www.pottertoncommercial.co.uk](http://www.pottertoncommercial.co.uk)

**POTTERTON**  
COMMERCIAL

heating specialists

